



LANZBURGINI FK937

搭建指南
BLOCK RACING



E





Instruction Manual tips / Wskazówki dotyczące instrukcji obsługi / Tipy v návode na použitie / Tipy v návode k použití

1

Open the numbered bags according to the instructions / Otwieraj ponumerowane woreczki zgodnie z instrukcją / Otvorte očíslované vrecká podľa pokynov / Otvérite očíslované sáčky podľa návodu

Bag G and unnumbered bags should be opened first / Woreczek G oraz woreczki nieponumerowane należy otworzyć na początku / Vrecko G a nečíslované vrecia by sa mali otvoriť ako prvé / Sáček G a nečíslované sáčky by měly být otevřeny jako první

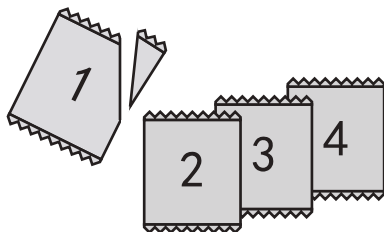
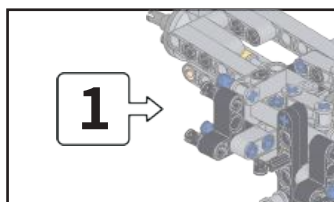

2

Use the 1:1 legend to quickly find parts of the right length / Użyj legendy 1:1, aby szybko znaleźć części o odpowiedniej długości / Použite legendu 1:1 na rýchle nájdenie častí správnej dĺžky / Použijte legendu 1:1 k rychlému nalezení částí správné délky

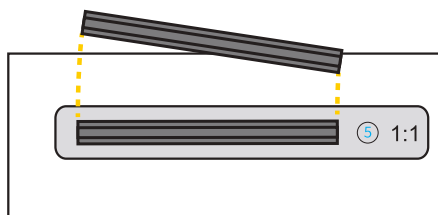
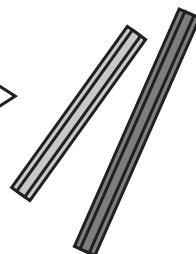

3

The meaning of the icons in the instruction manual
Znaczenie ikon w instrukcji obsługi
Význam ikon v návode na použitie
Význam ikon v návode k použití



Rotate the structures
Obróć konstrukcje
Otočte štruktúry
Otočte struktury



The number indicates the corresponding sticker number
Liczba wskazuje odpowiedni numer naklejki
Číslo označuje príslušné číslo nálepky
Číslo označuje odpovídající číslo nálepky

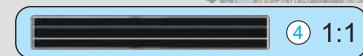
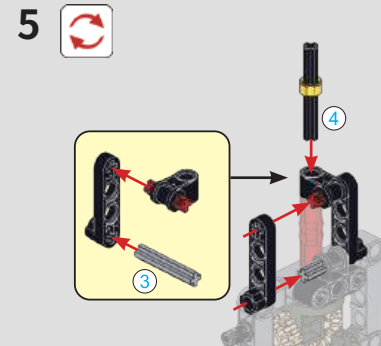
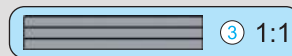
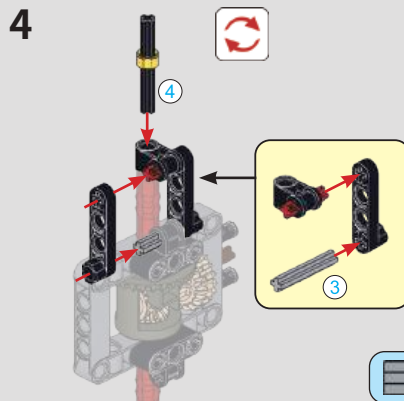
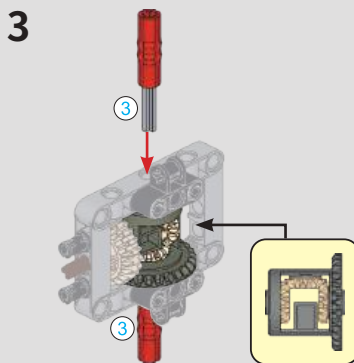
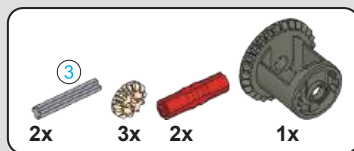
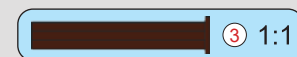
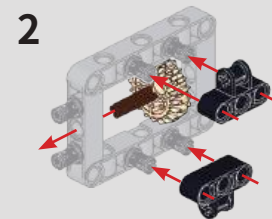
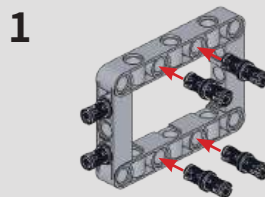
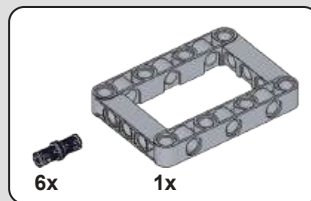
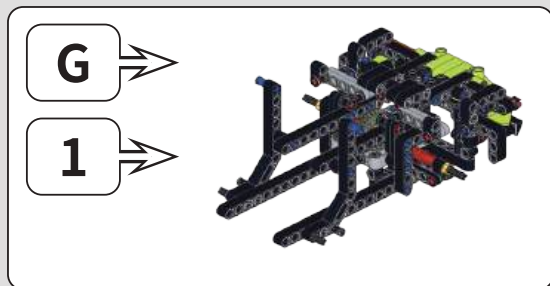



6

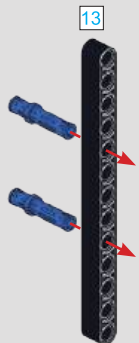

7

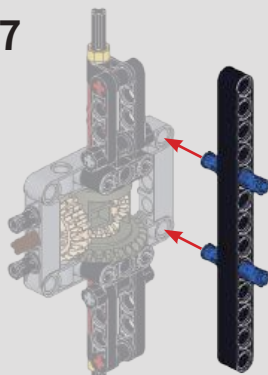

8

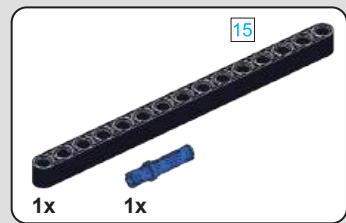
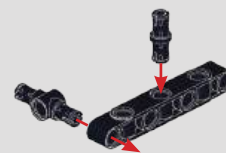

9

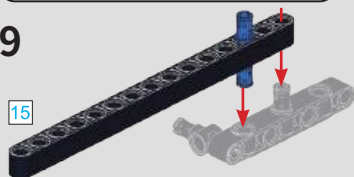

10

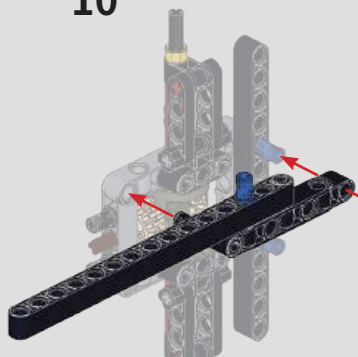

11

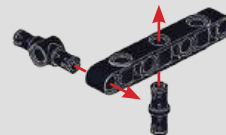

02



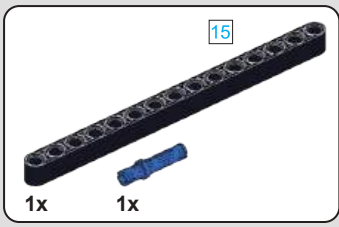

12

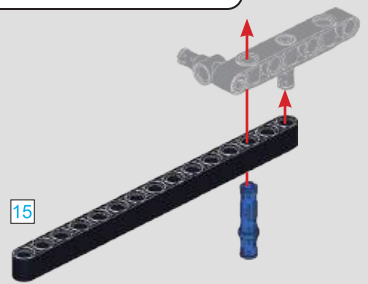

13

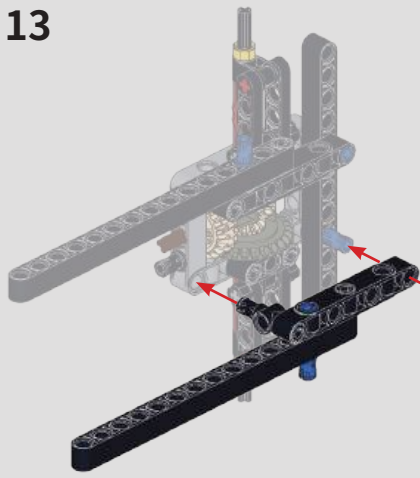

14



15

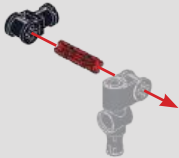

16

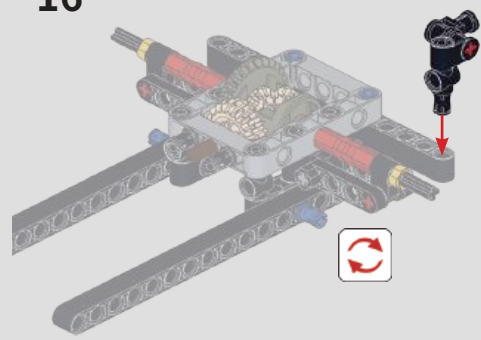

17



18

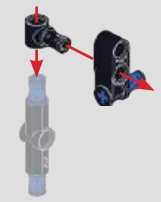



19

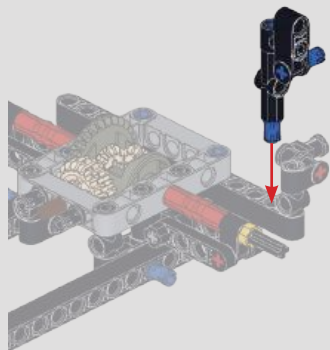

20

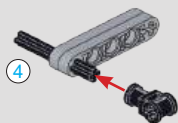

21

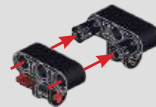

22

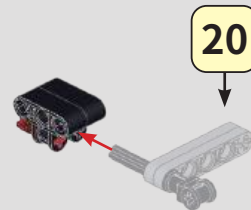

20



4 1:1



11 1:1



23

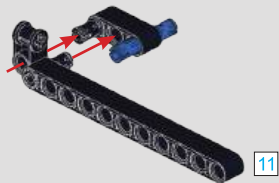

24



25

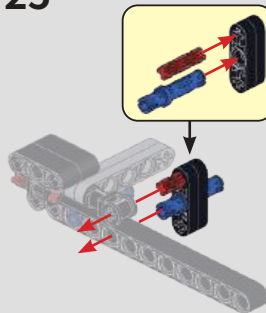

26

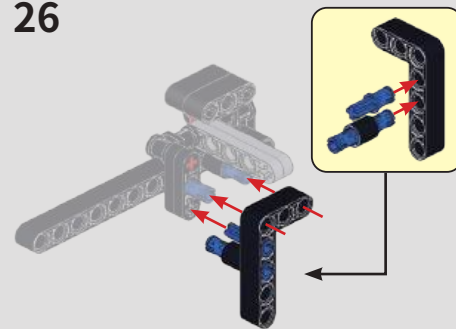

04



27

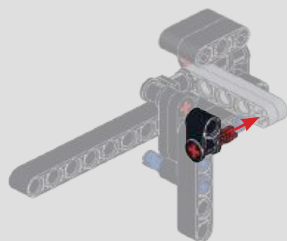

28

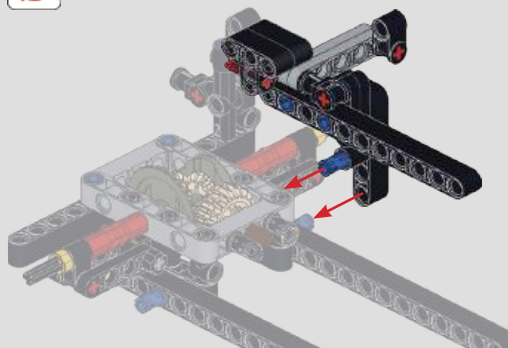

29



30

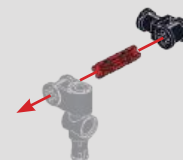

31

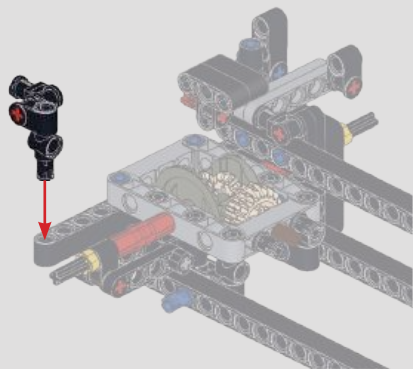

32



33

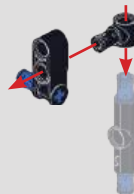

34

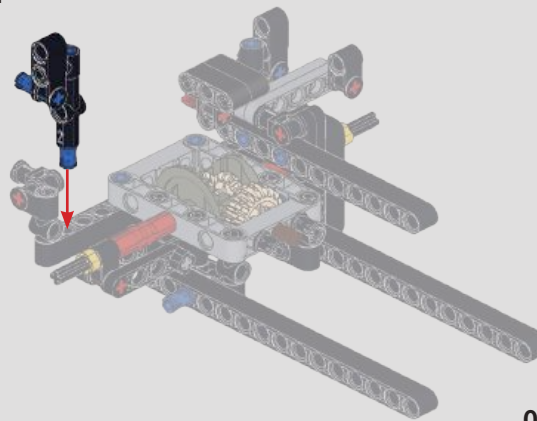

05

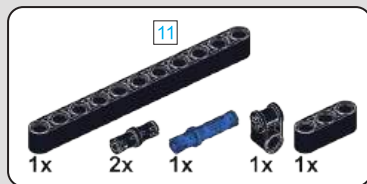

35

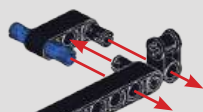

11



36

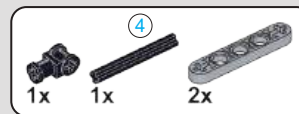
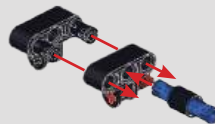

37

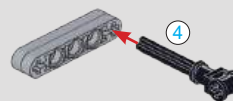

38

36

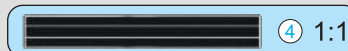
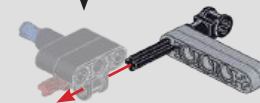

39



40

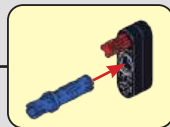
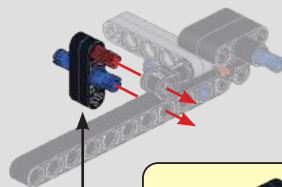
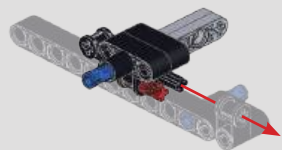

41

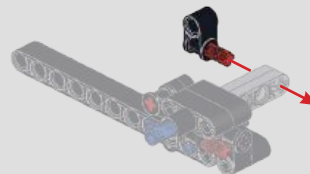

42

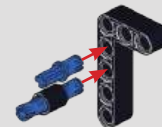

06





43

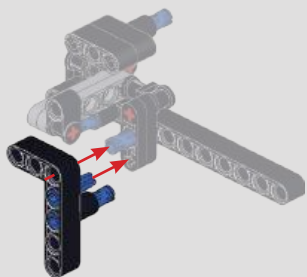

44

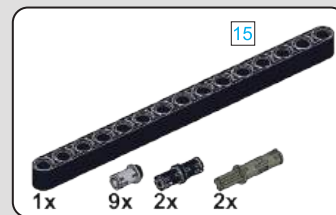
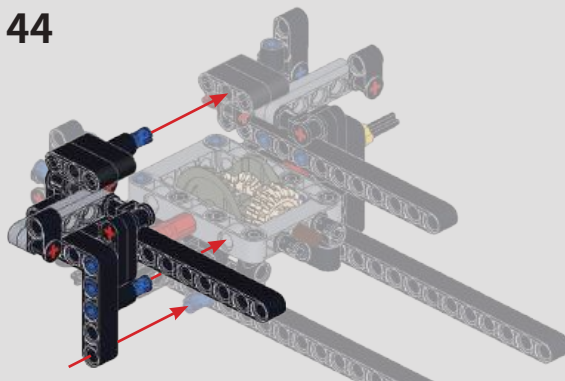

45



46

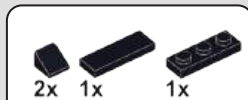
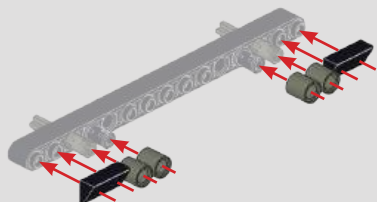

47

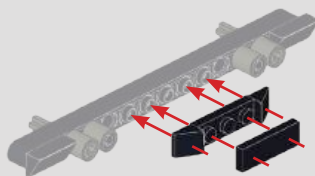

48

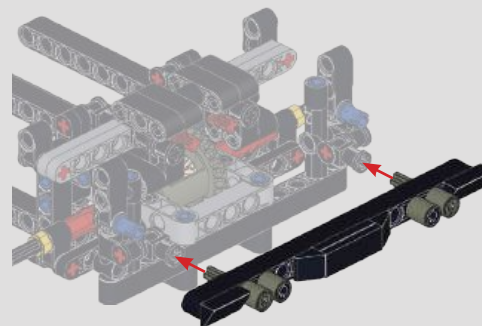

07

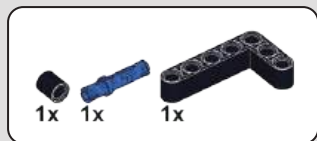

49

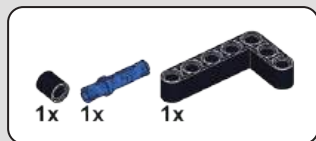
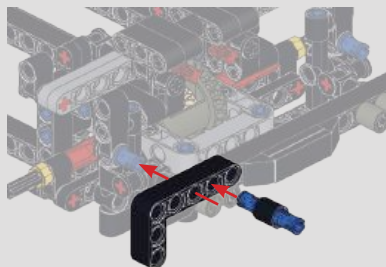

50

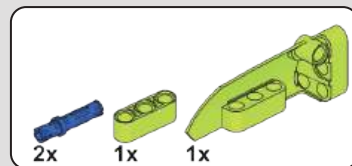
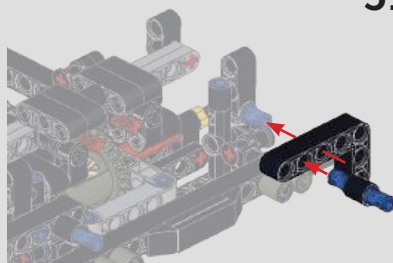

51

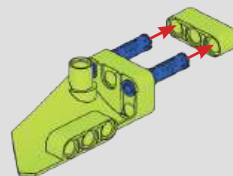

52

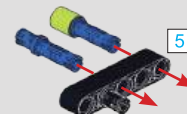

53

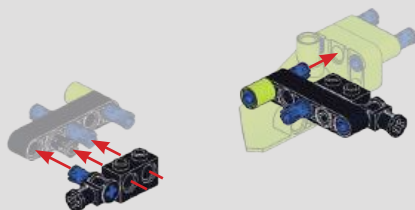

54



55

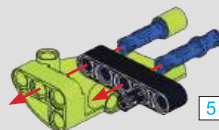

56

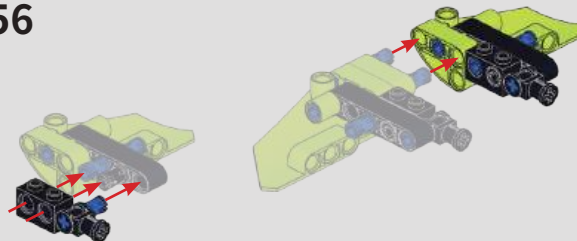

57



58

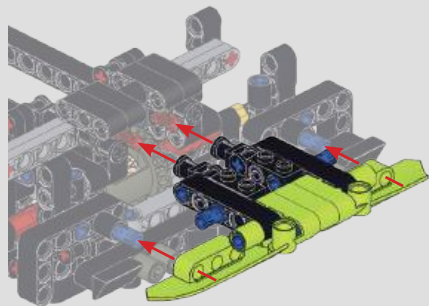

59

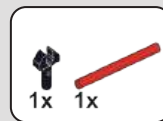
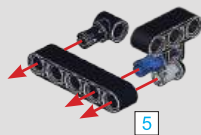

60

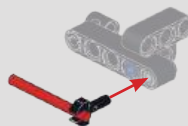

61

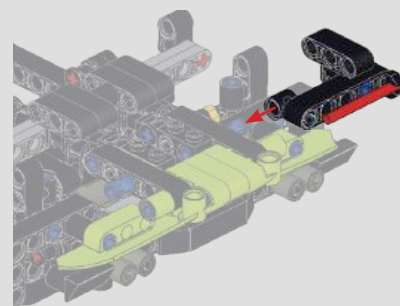

62

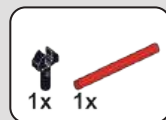
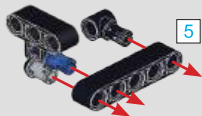

63



64

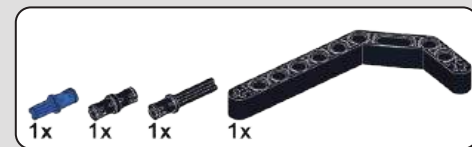
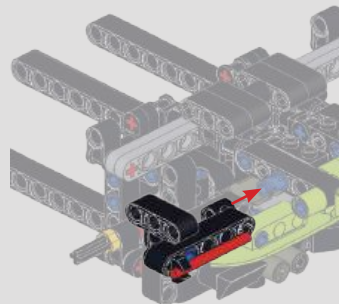

65



09



66

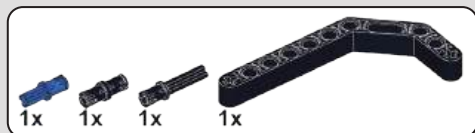
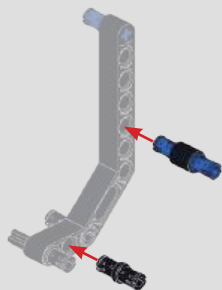

67



68

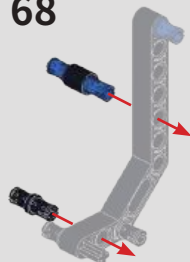

69

66

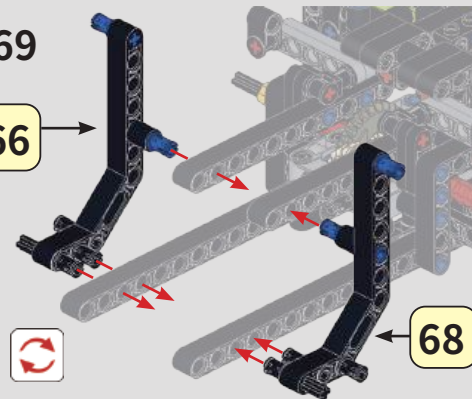

68

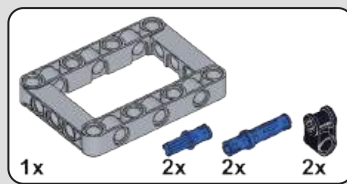
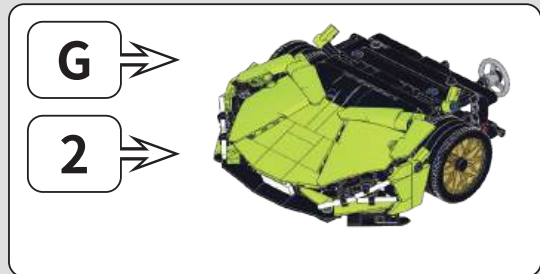

70

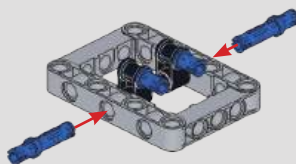

71

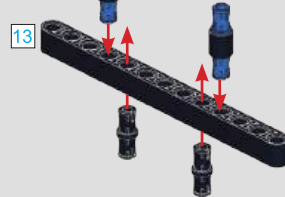



73



72

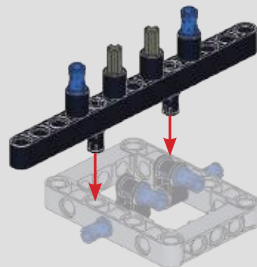
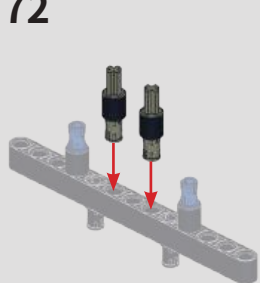

74

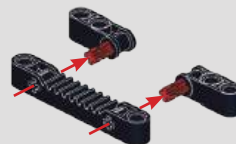

75

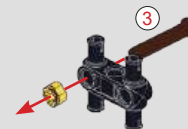

76

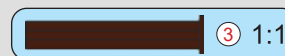

79

80

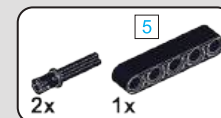

77

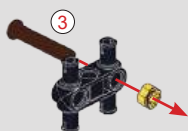

78

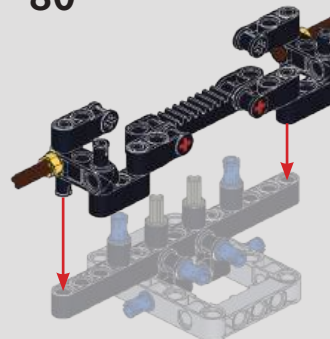
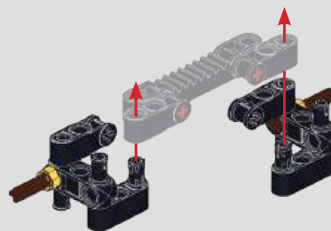
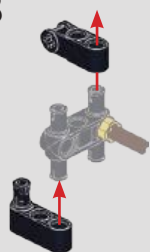

81



11



82

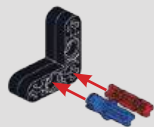

83

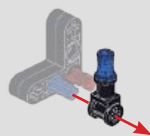

84

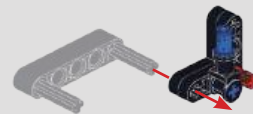

85

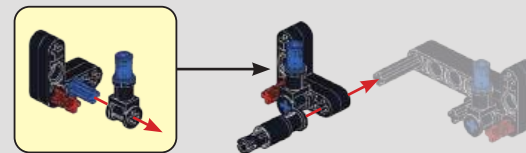

86

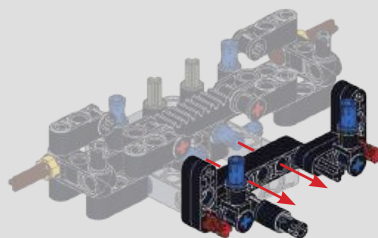

87

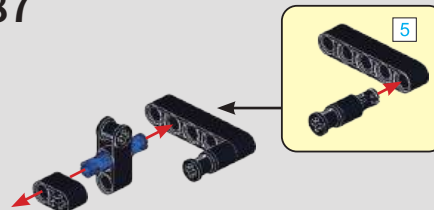

88

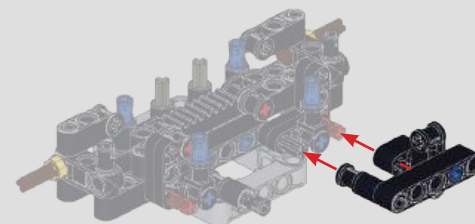

12



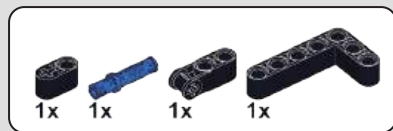

89

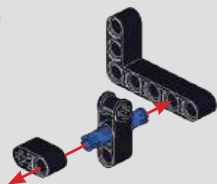

90

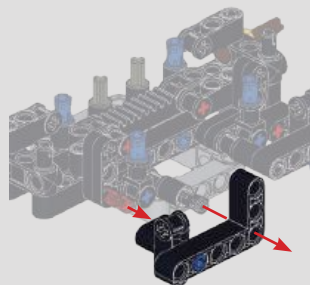

91



92

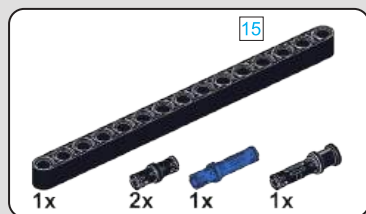
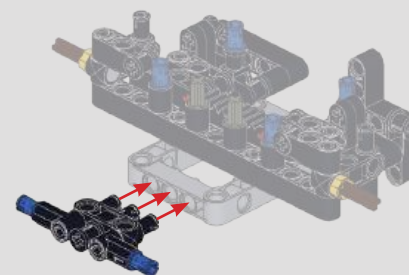

93

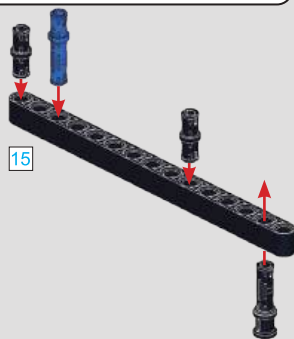

94

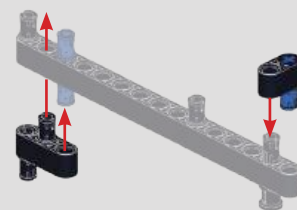

95

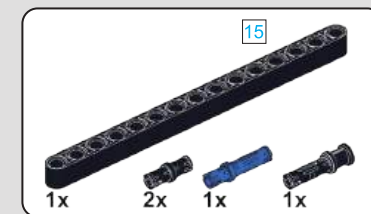
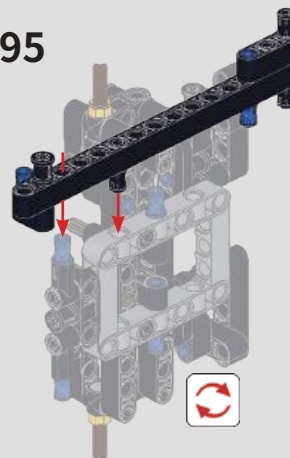

96

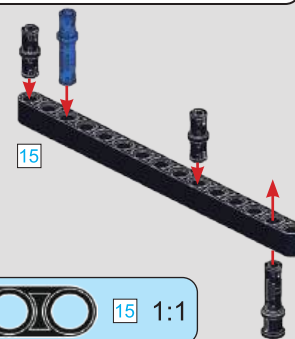

13

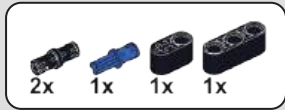

97

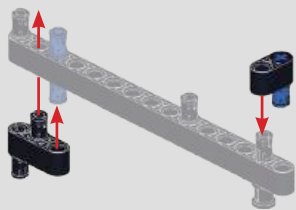

98

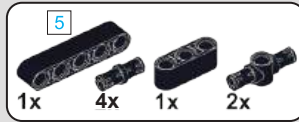
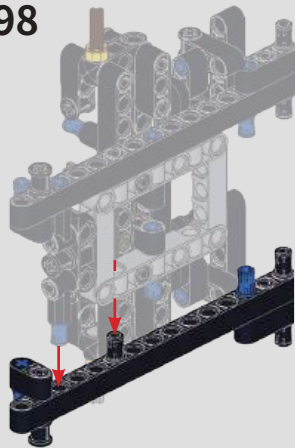

99

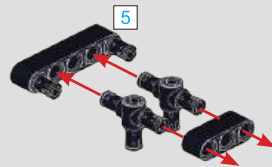

100

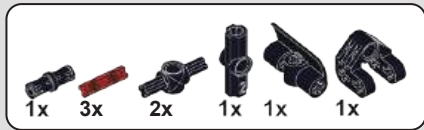
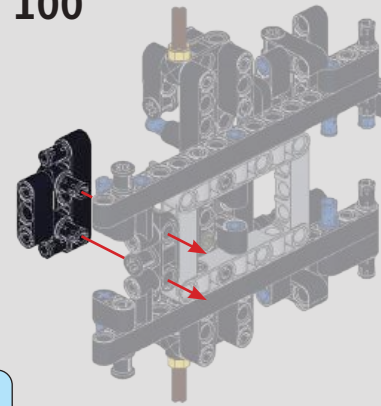

101

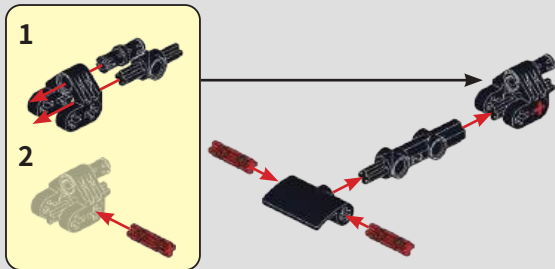

14

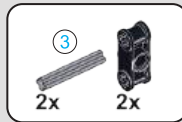

102

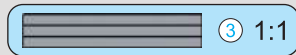
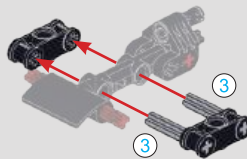

103

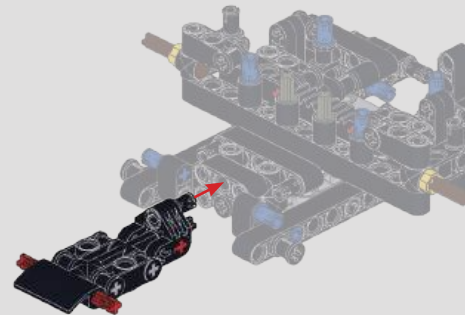



104

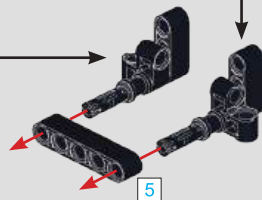
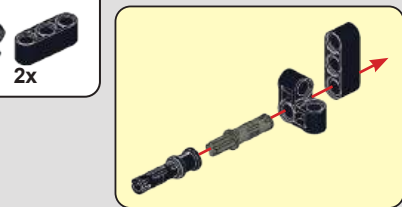
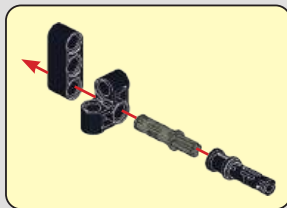

105

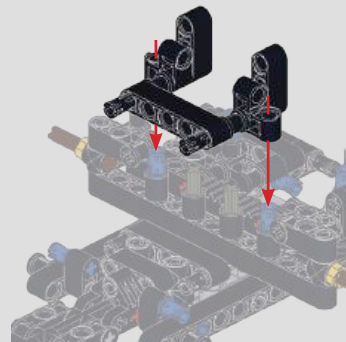

106

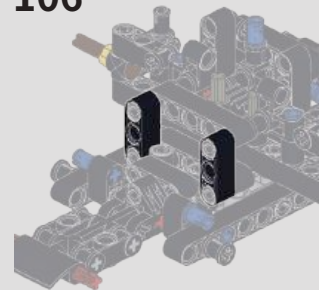

107

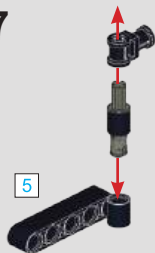

108

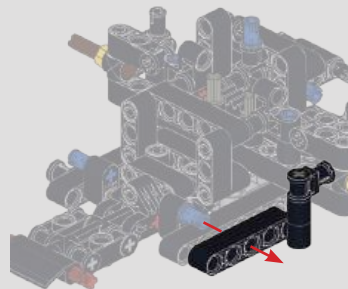

109

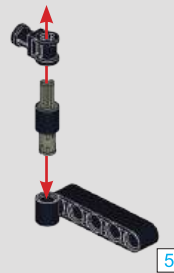

110

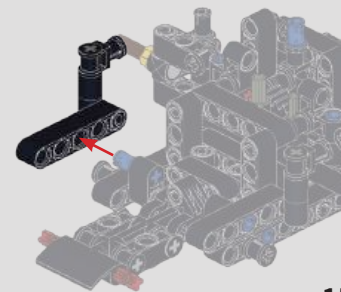

15



111

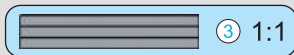
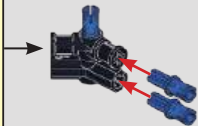

112



113

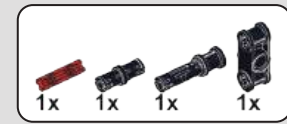

114

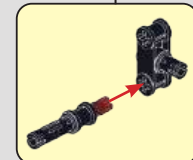

115



116

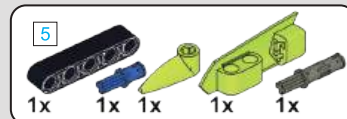
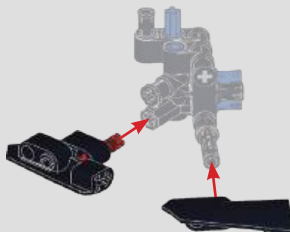

117

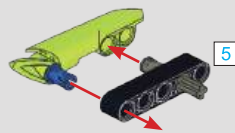

118

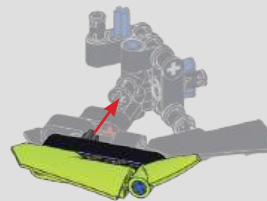

119

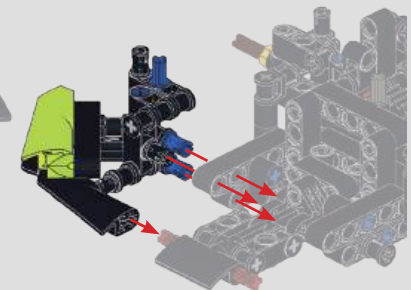

16





120

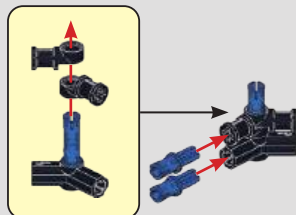

121

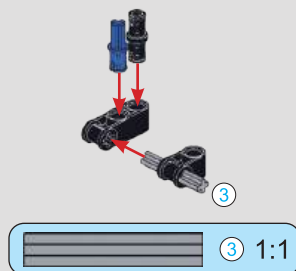

122



123

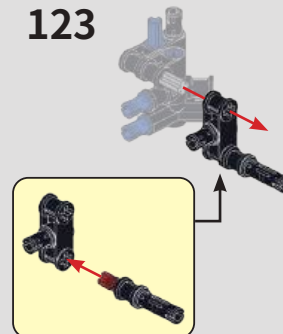

124



125

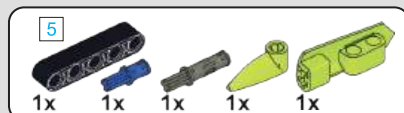
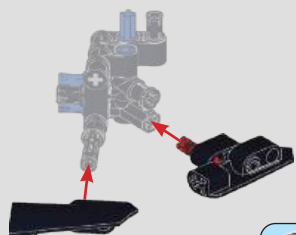

126

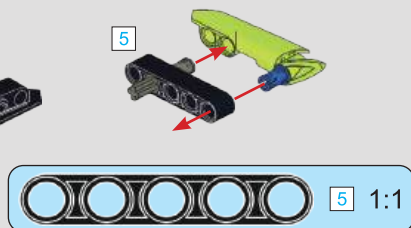

127

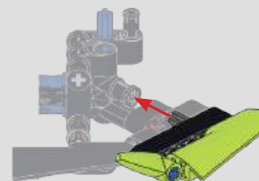

128

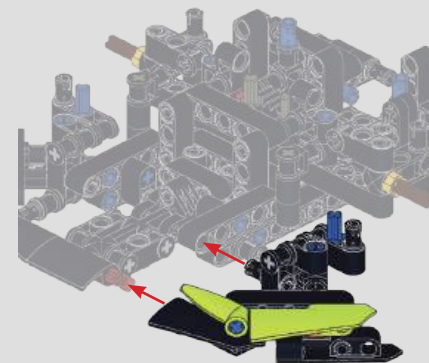

17



129

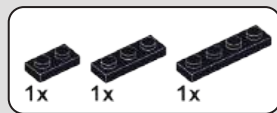

130

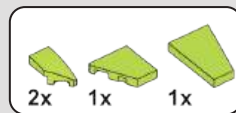
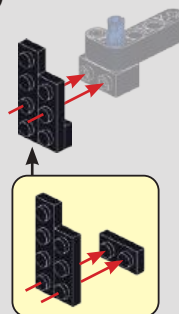

131

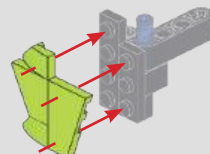

132

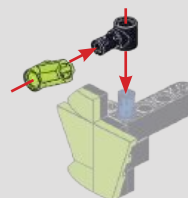

133

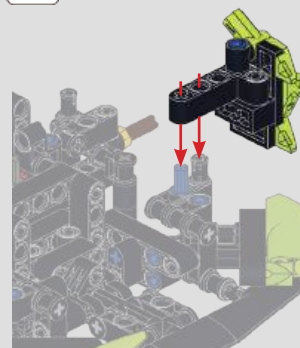

134

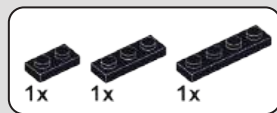
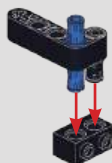

135

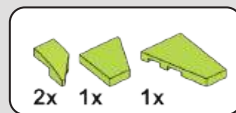
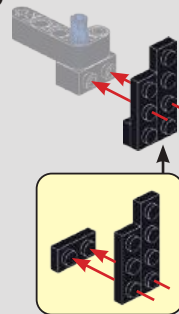

136

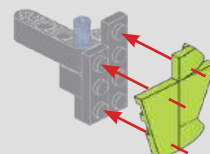

137

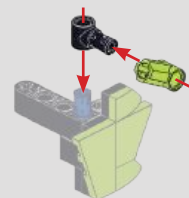

138

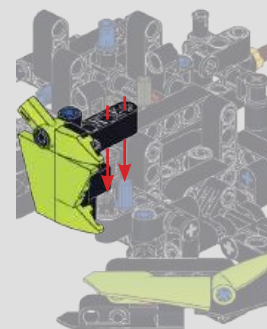

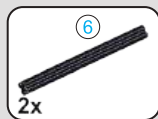

139

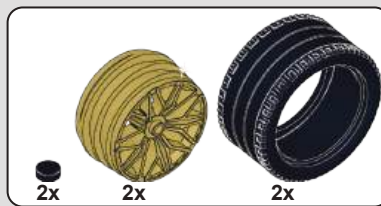
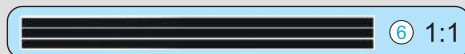
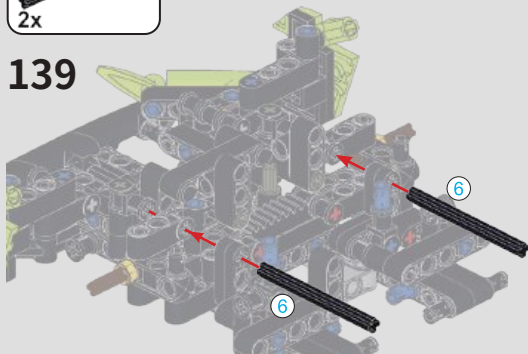

140

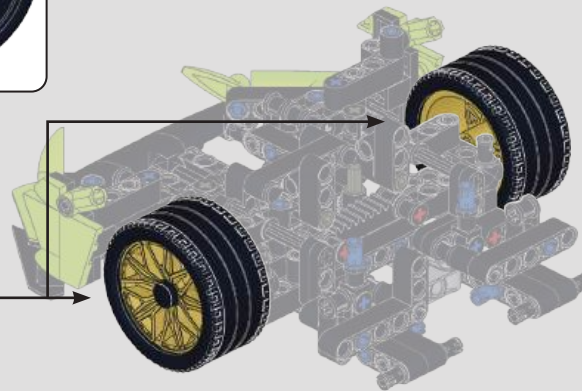
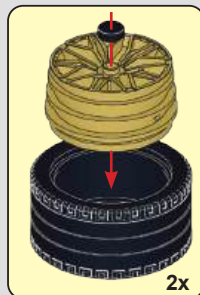

141

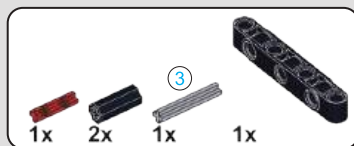
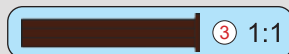
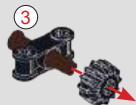

142

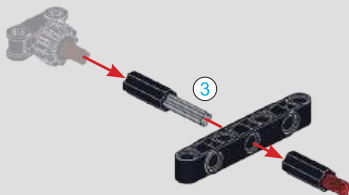

143

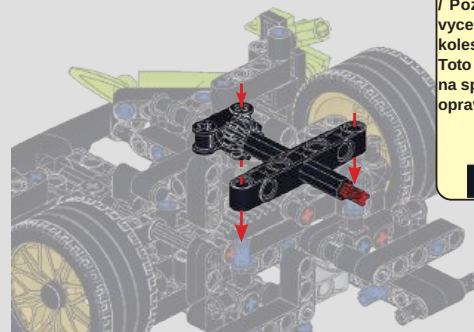

Note: This gear should be centered on the lower part and the front wheel should be corrected / Uwaga: To koło zębate powinno być wyśrodkowane w dolnej części i przednie koło należy skorygować / Poznámka: Tento prevod by mal být vycentrovaný na spodnej časti a predné koleso by sa malo opraviť / Poznámka: Toto ozubené kolo by mělo být vystředěno na spodní části a přední kolo by mělo být opravenot wheel should be corrected





144

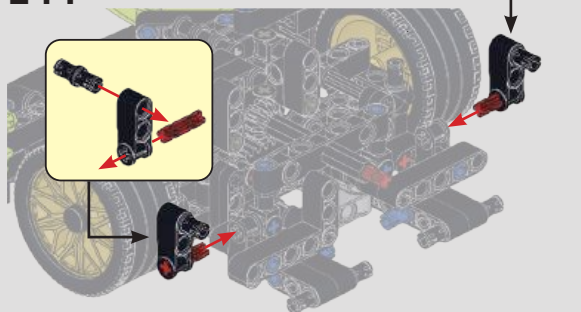

145

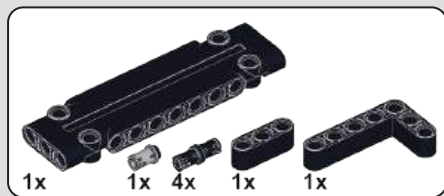
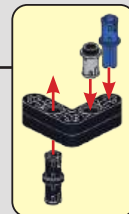
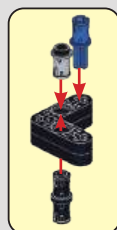
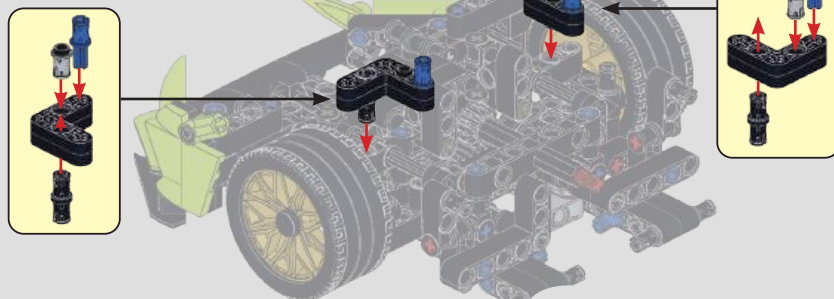

146

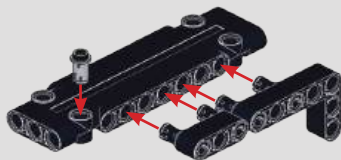

147

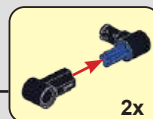
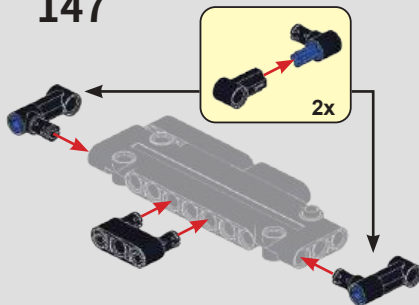

148

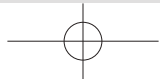
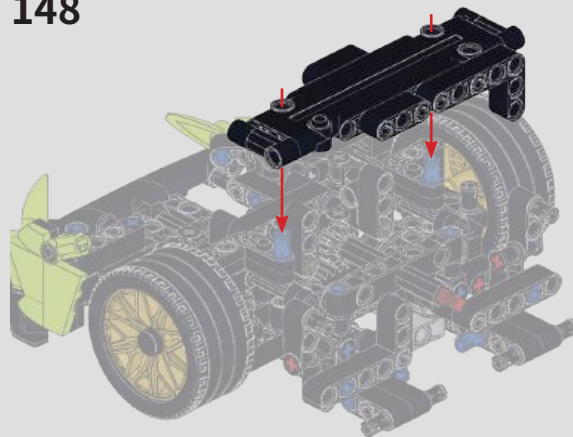

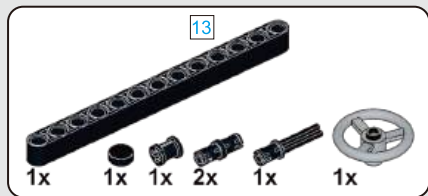

149

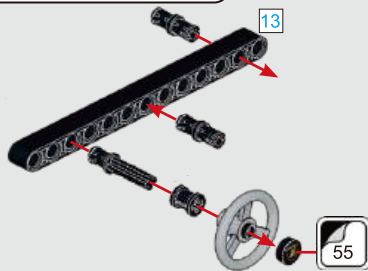

150

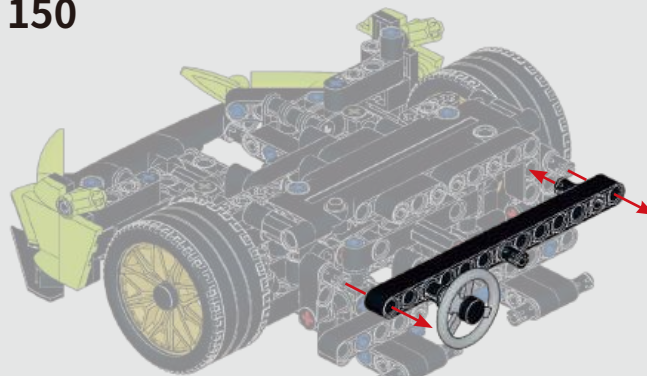

151

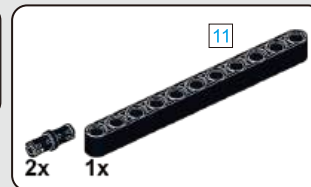
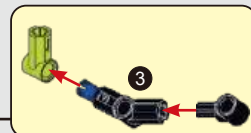
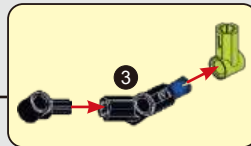
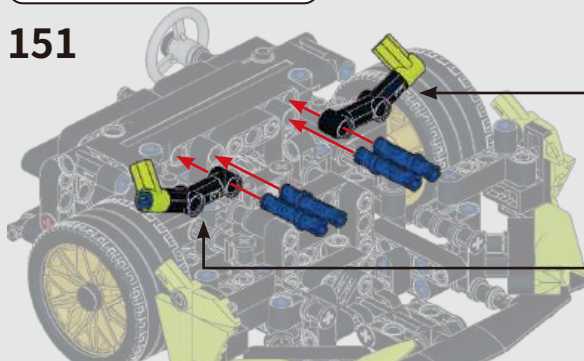

152



21



153

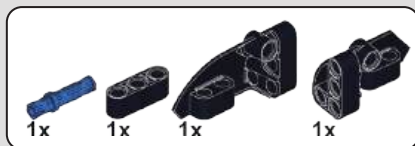
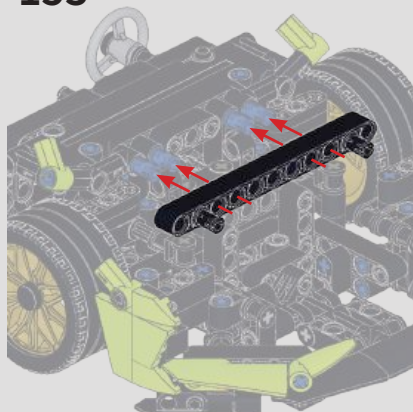

154

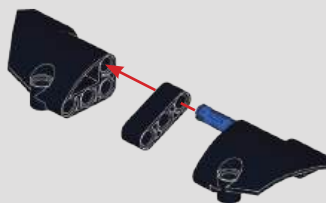

155

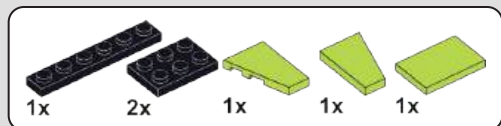
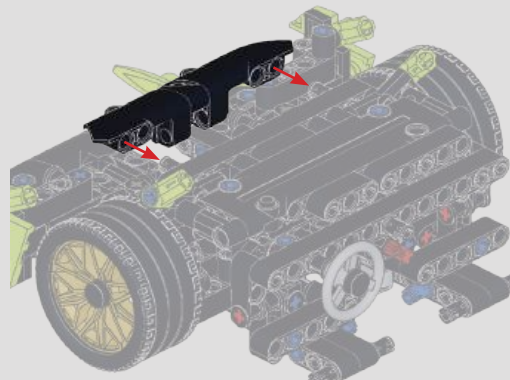

156

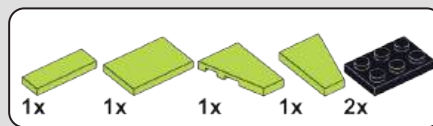
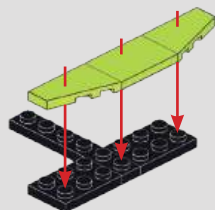

157

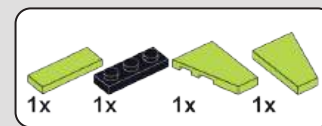
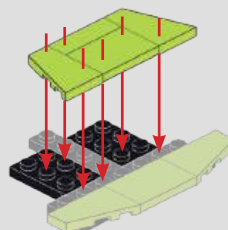

158

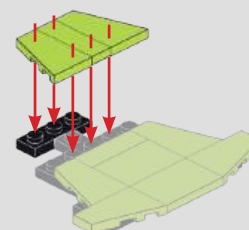

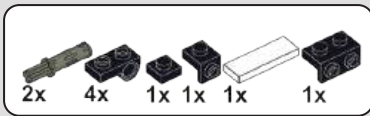

159

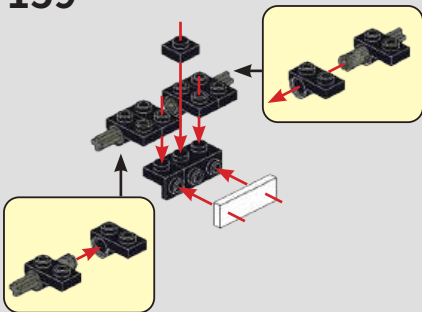

160

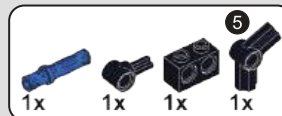
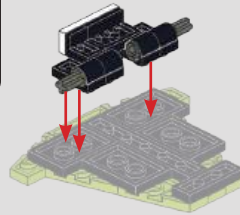

161



162

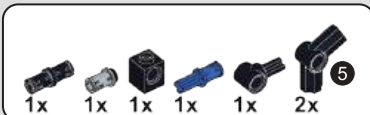
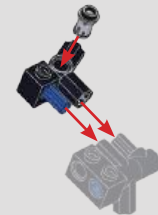

163

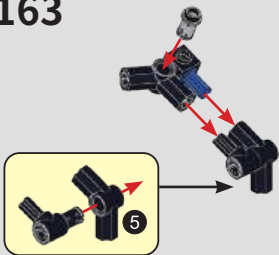

164

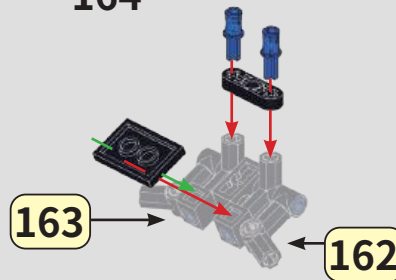

165

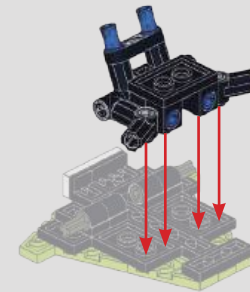

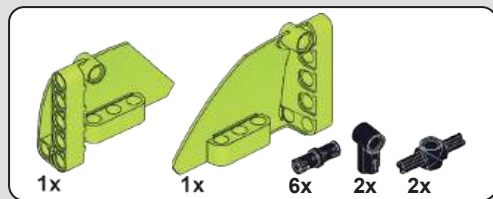

166

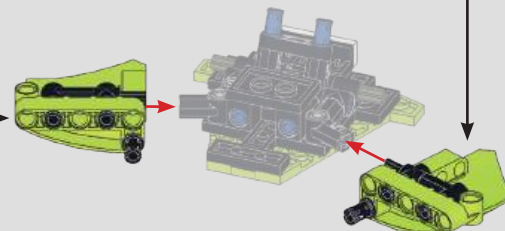
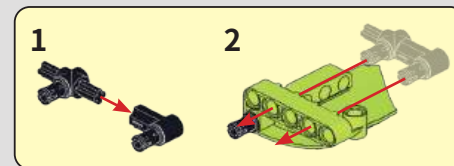
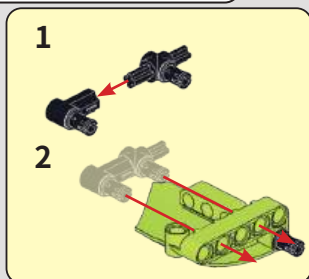

167

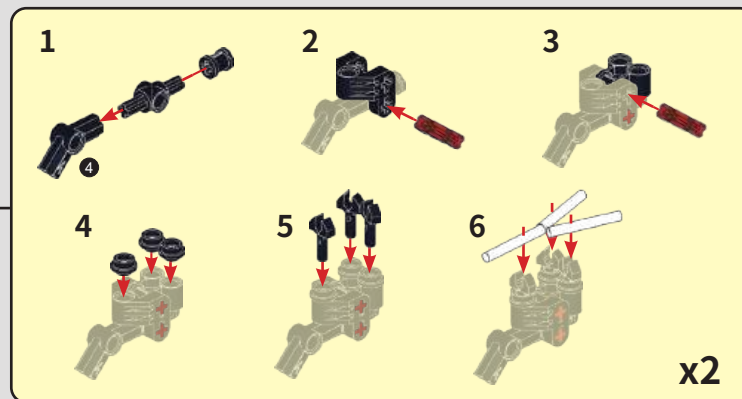
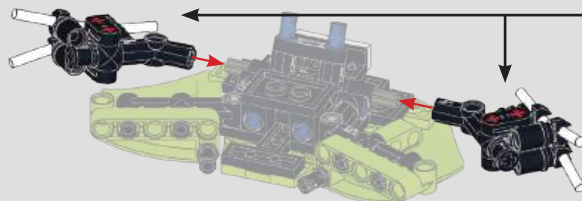

24



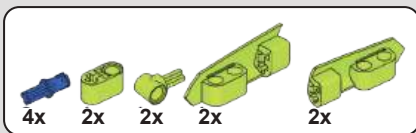

168

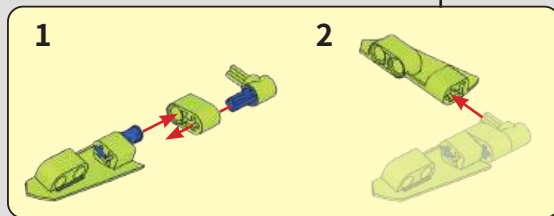
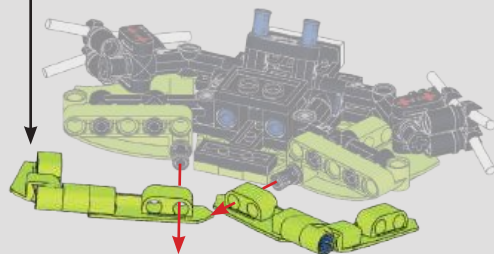
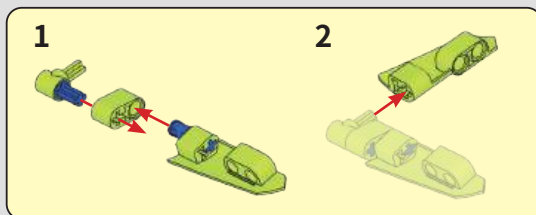

169

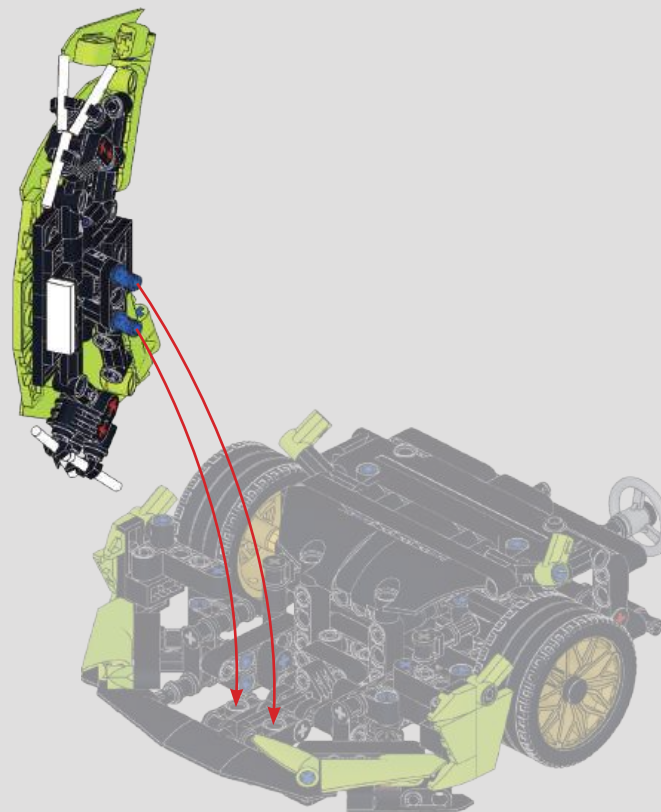

25

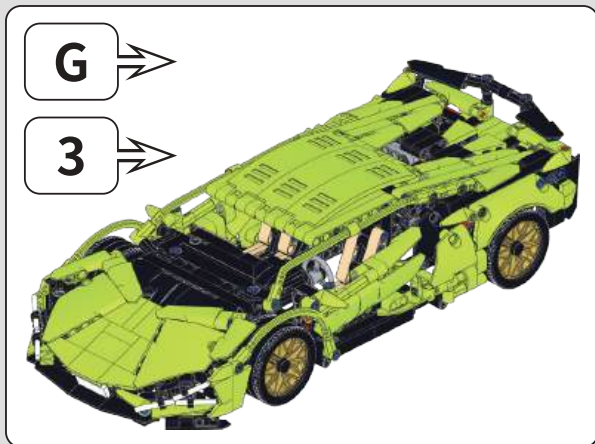

170

169

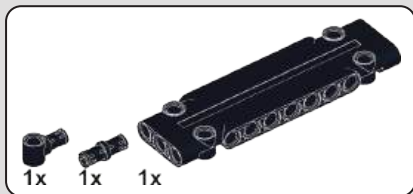
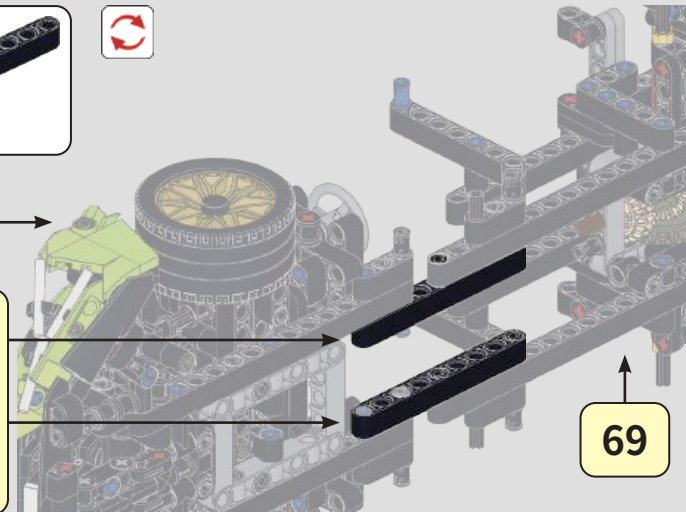
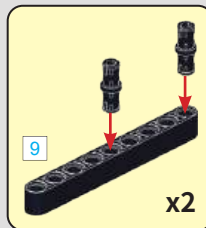

171

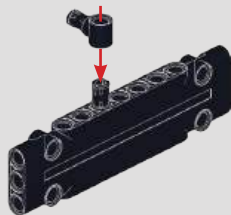

26



172

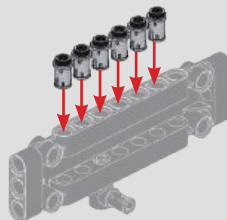

173

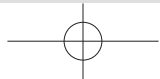
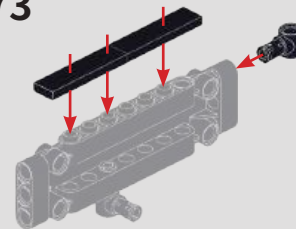



174

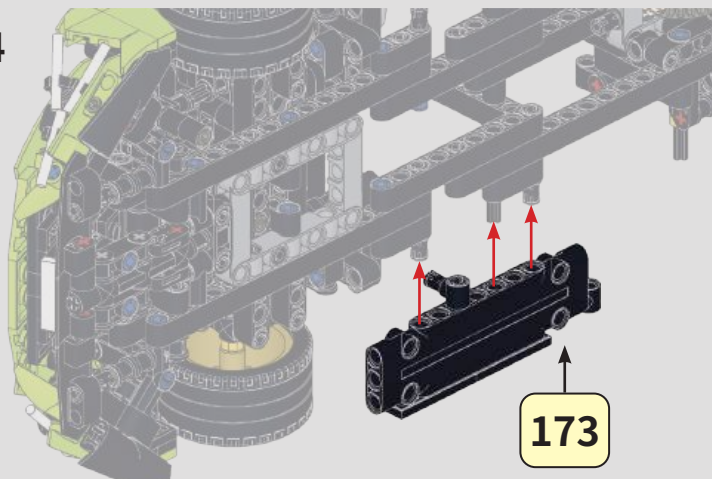

175



176

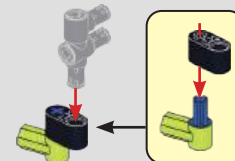

173



177

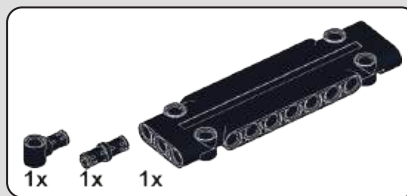
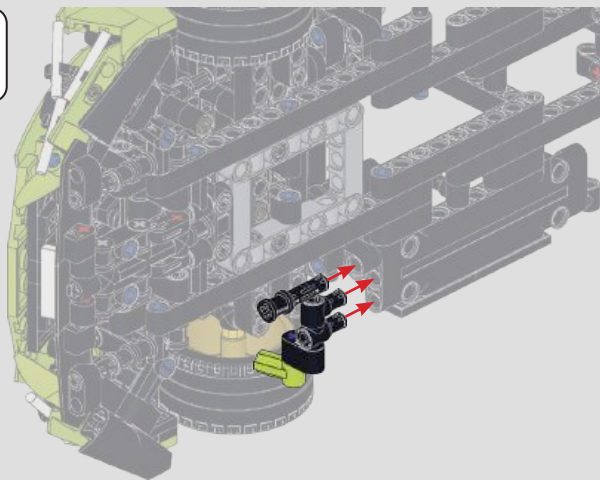

178

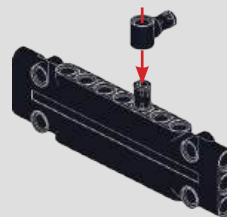

179

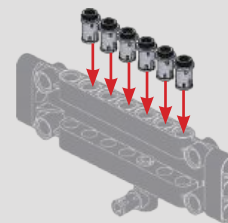



180

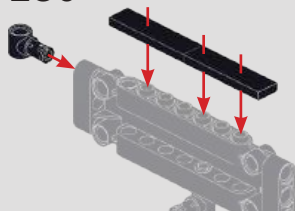

181

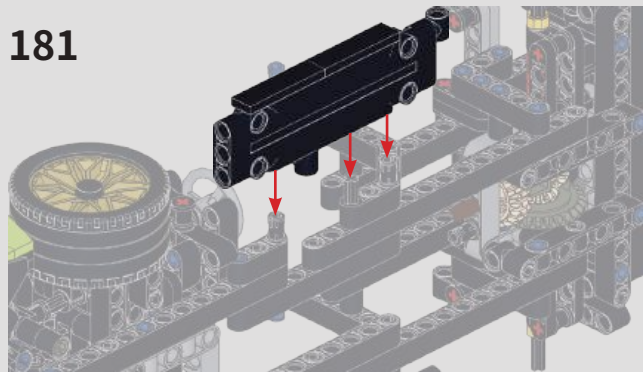

182

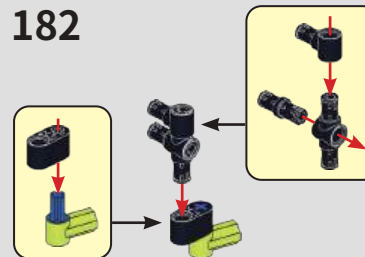

183

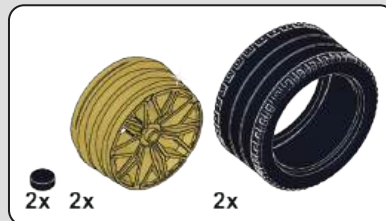
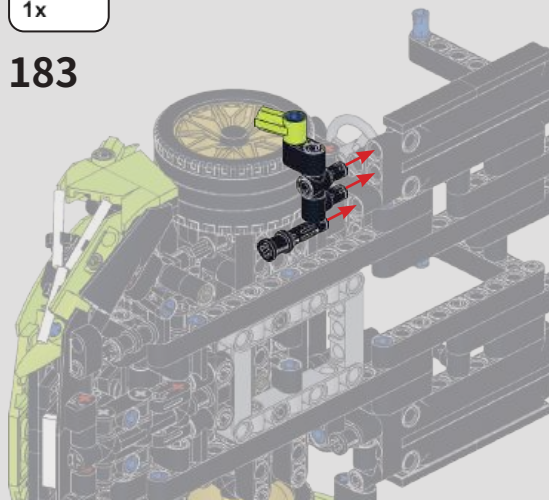

184

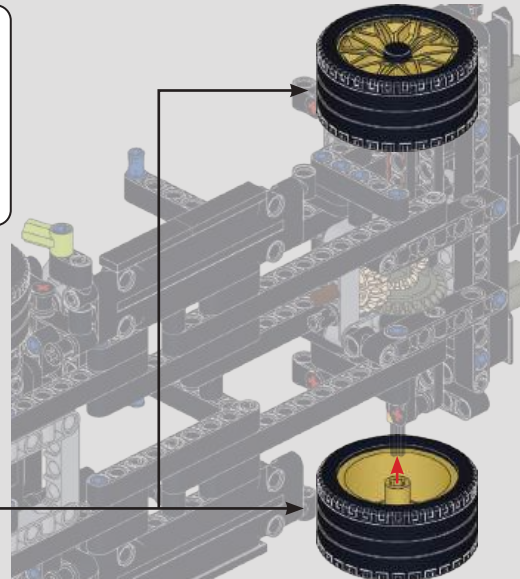
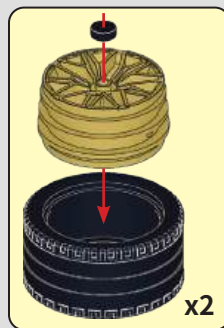

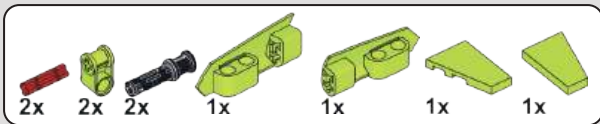

185

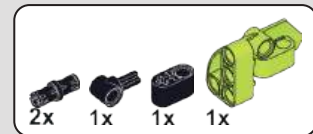
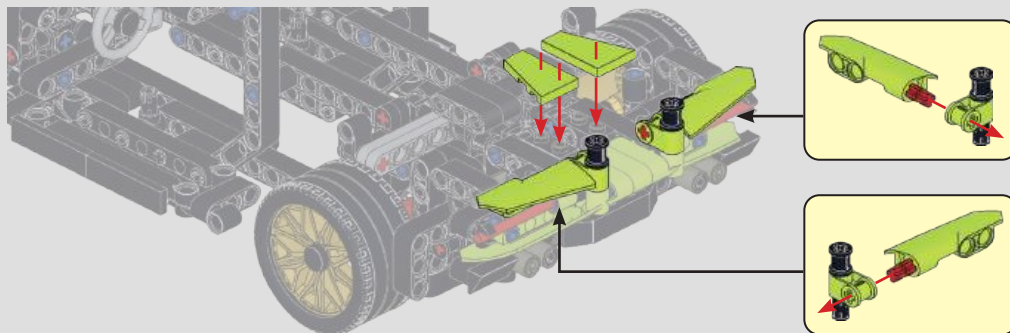

186

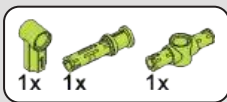
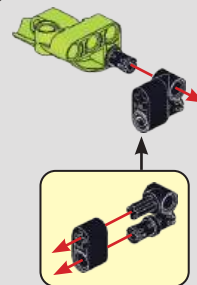

187

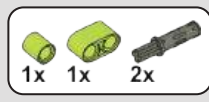
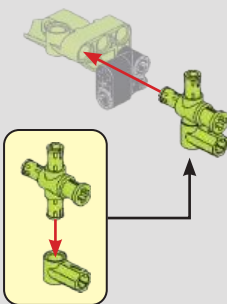

188

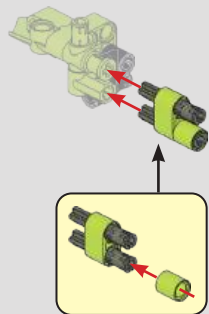

189

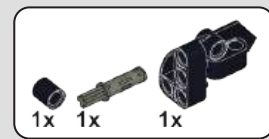
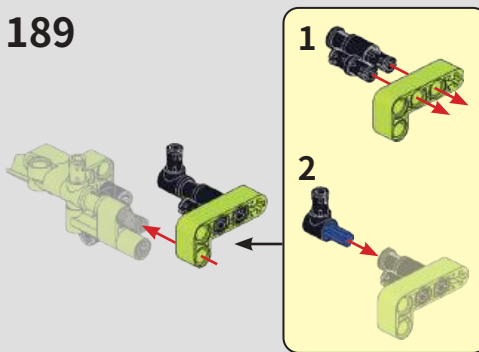

190

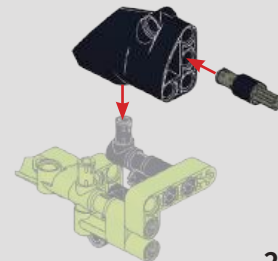

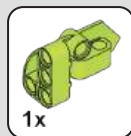

1x

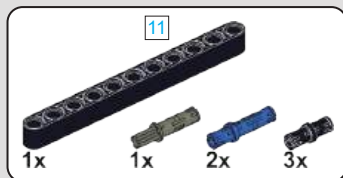
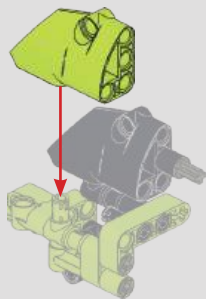

192

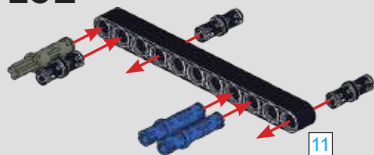

193

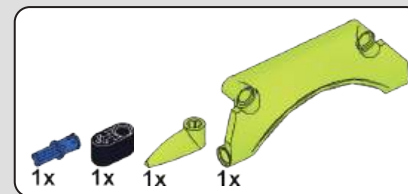
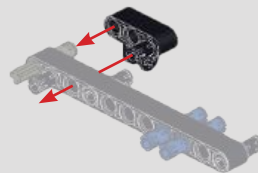

194

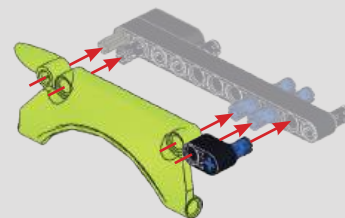

195

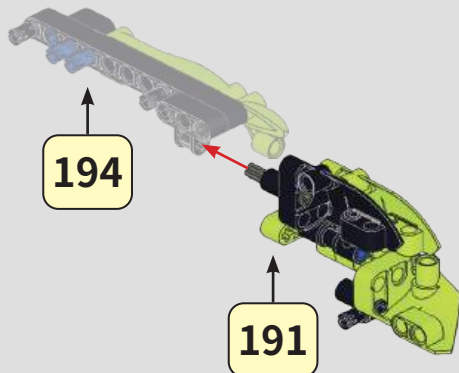

196

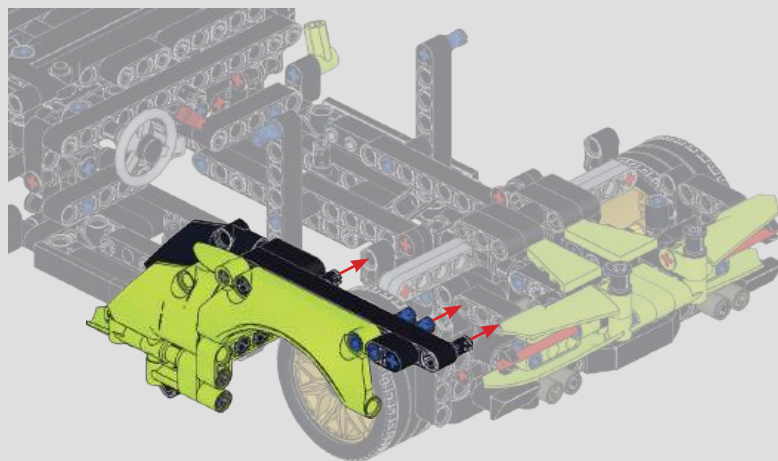



197

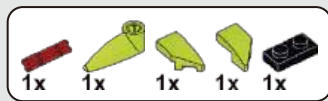
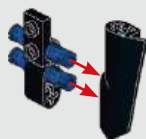

198

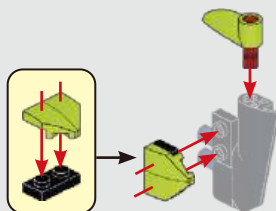

199

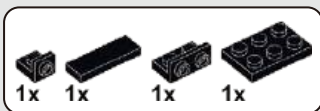
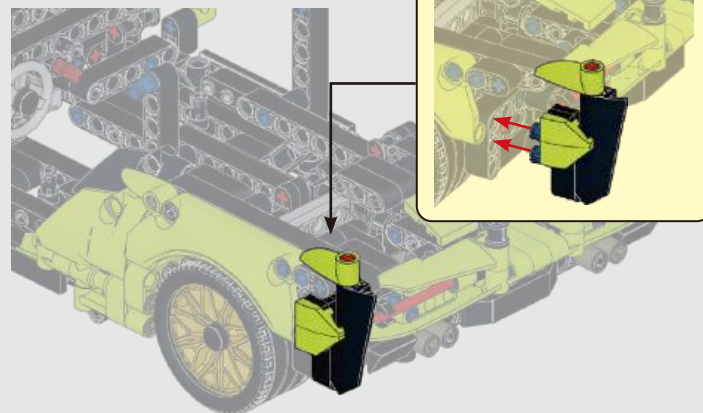

200

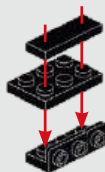

201

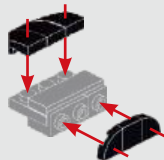

202

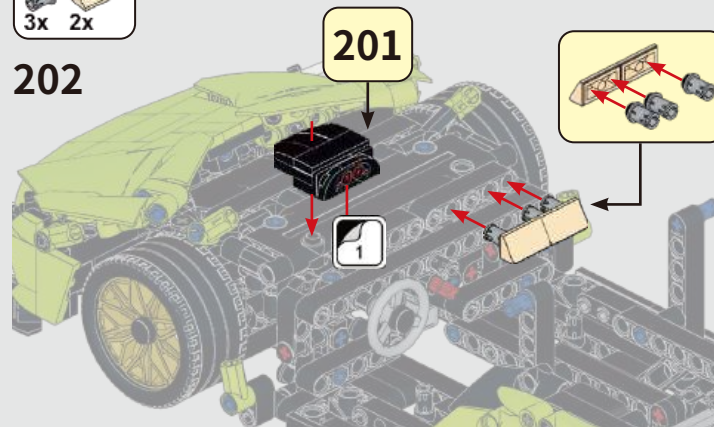

31

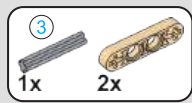

203

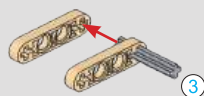

204

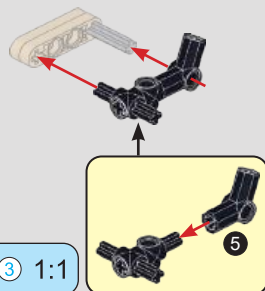

205

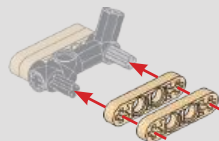

206

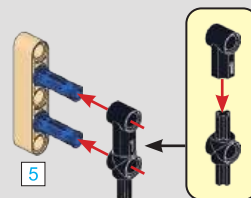

207

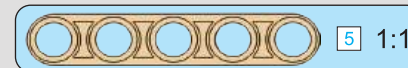
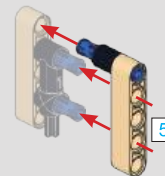

208

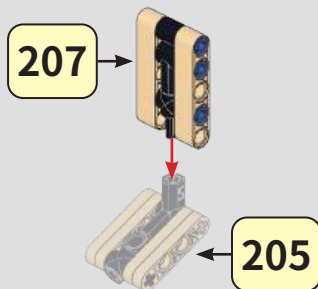

209

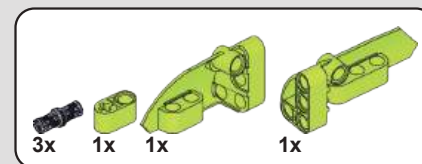
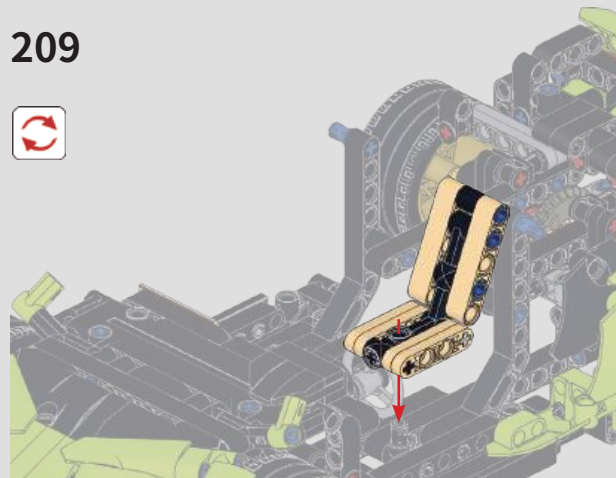

210

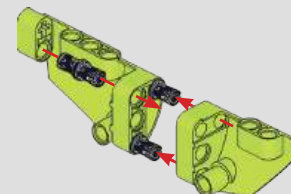

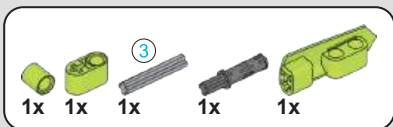

211

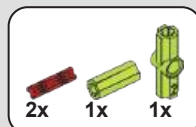
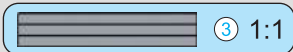
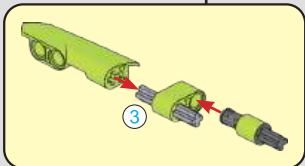
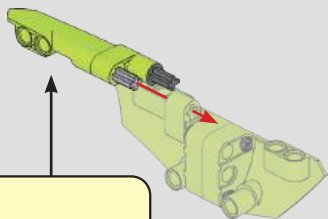

212

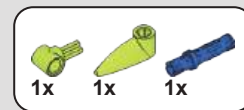
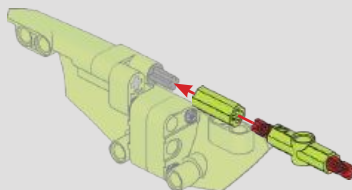

213

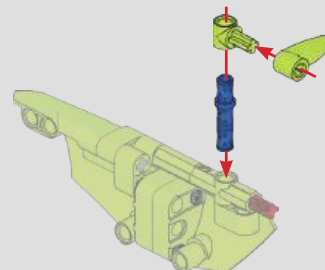

214

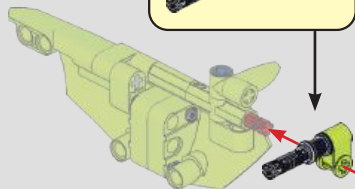
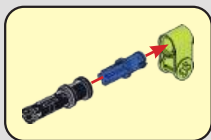

215

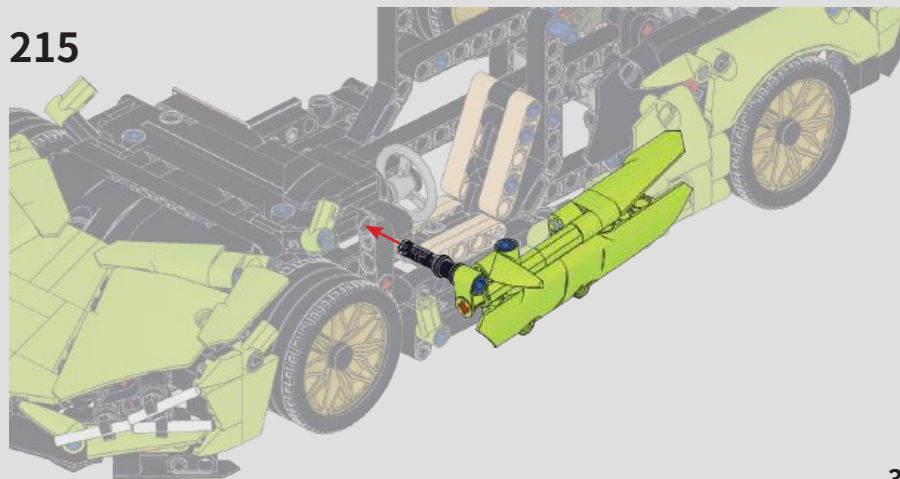

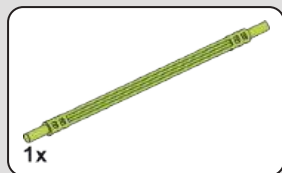

216

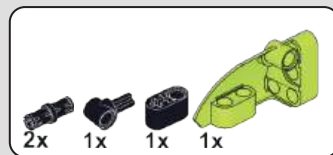
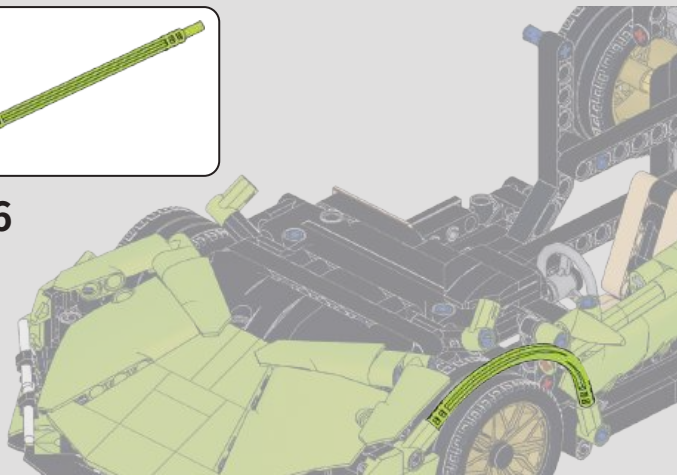

217

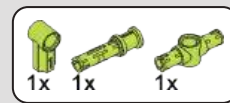
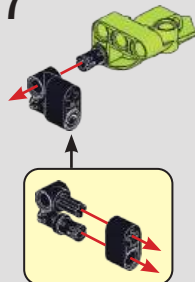

218

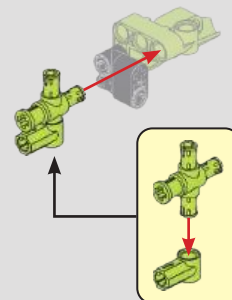

219

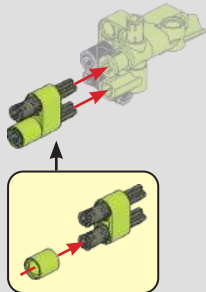

34



220

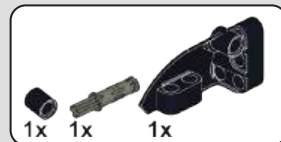
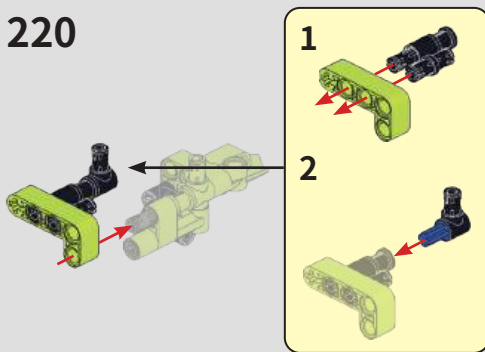

221

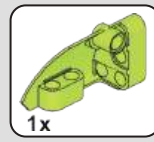
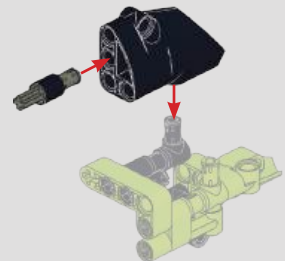

222

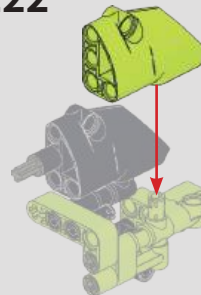

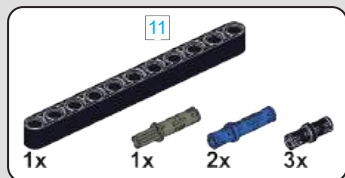

223

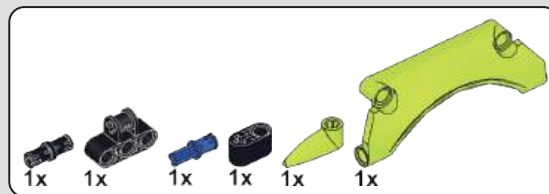
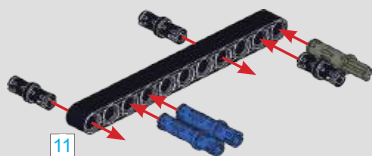

224

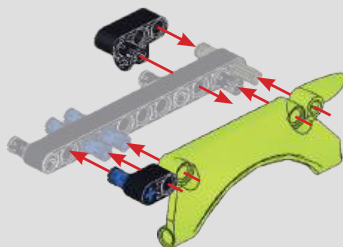

225

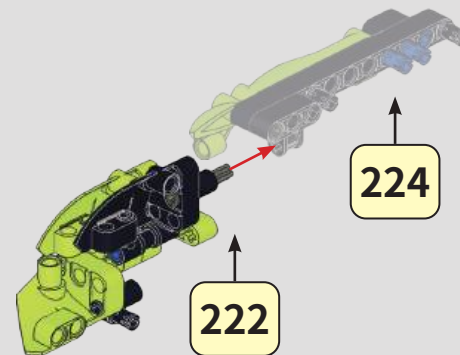

226

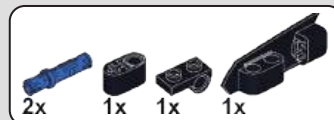
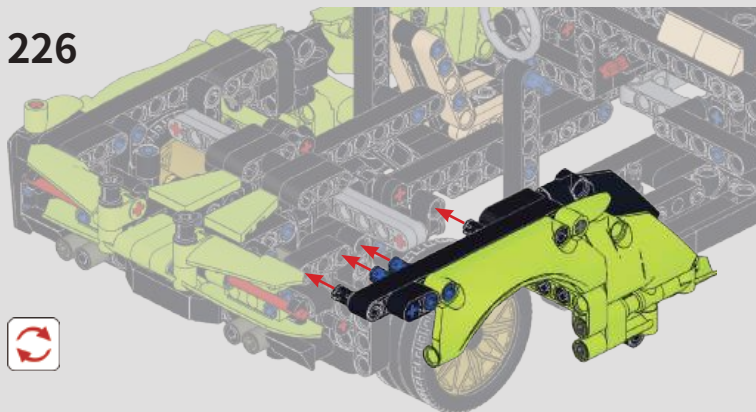

227

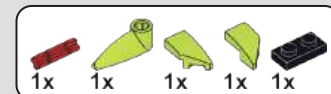
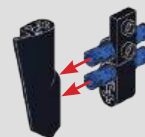

228

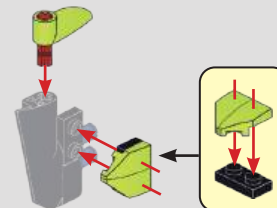

229

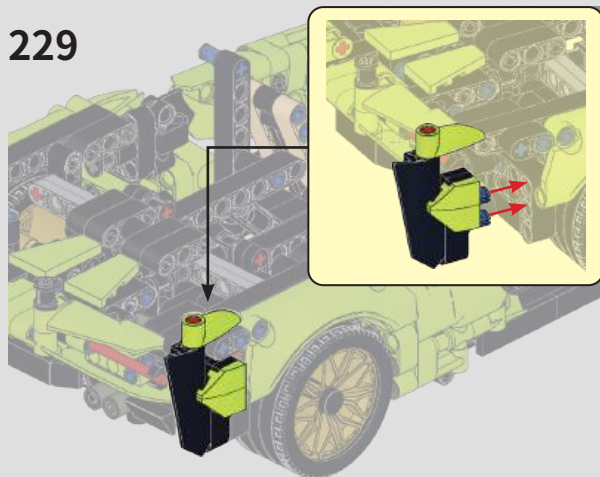

230

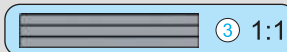
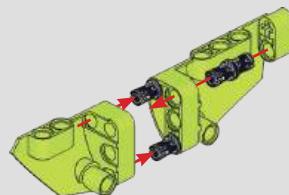
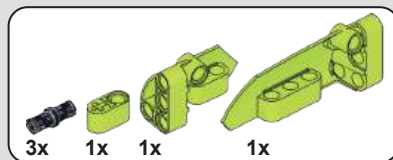

231

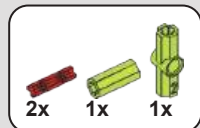
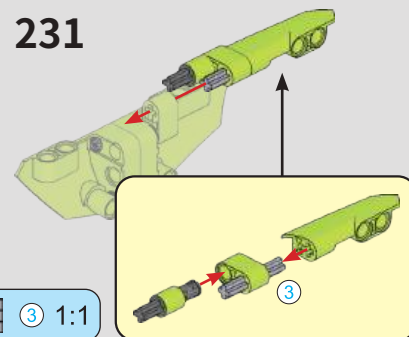
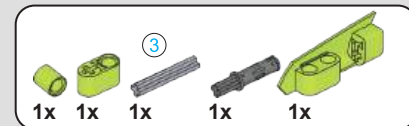

232

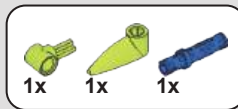
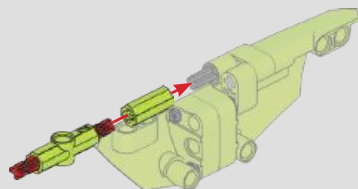

233

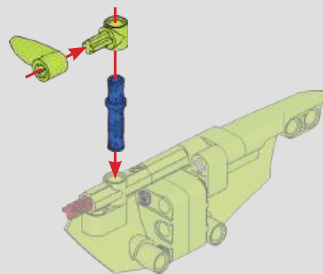

234

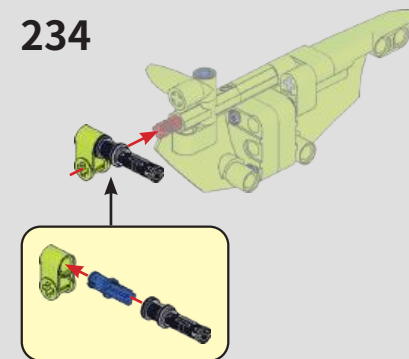

235

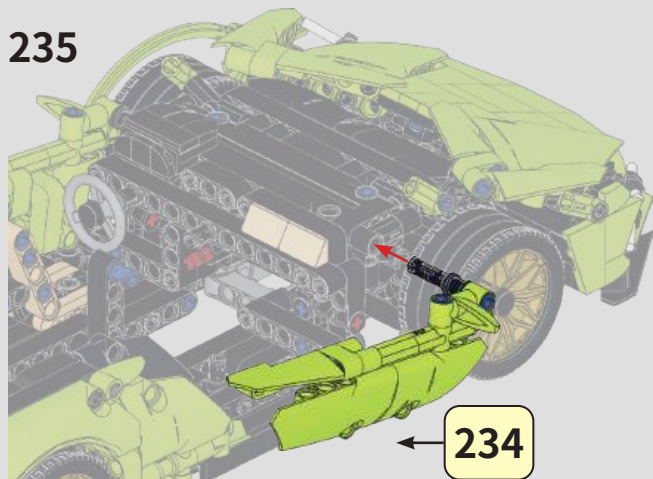

234

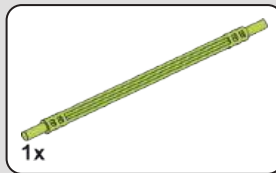

236

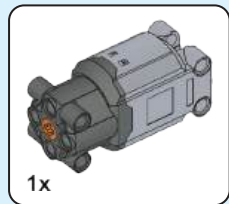
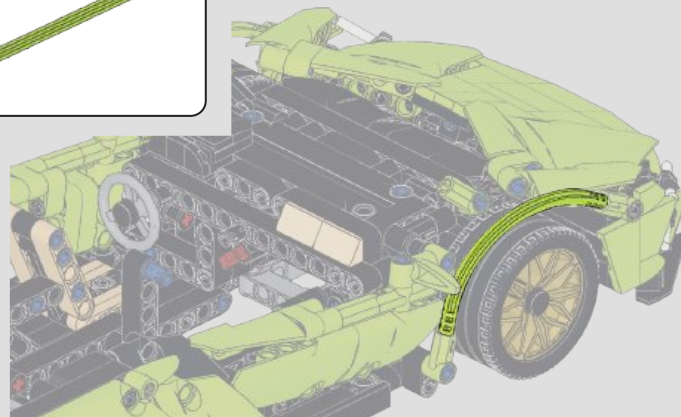

237

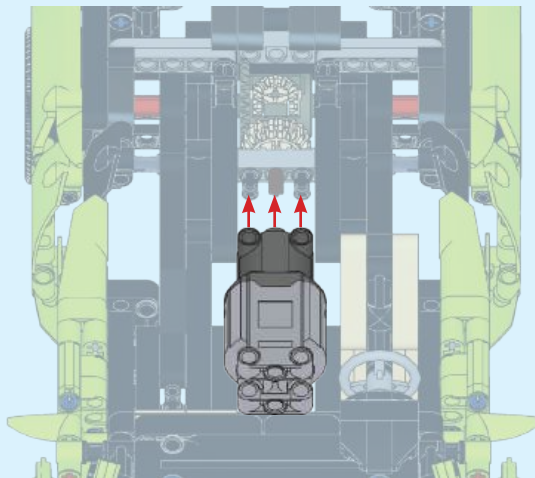

Note: The blue page shows the installation steps of the power version /
 Uwaga: niebieska strona pokazuje kroki instalacji wersji zdalnej /
 Poznámka: Modrá stránka s kroky vzdálenější instalace /
 Poznámka: Modrá stránka s kroky vzdálenější instalace

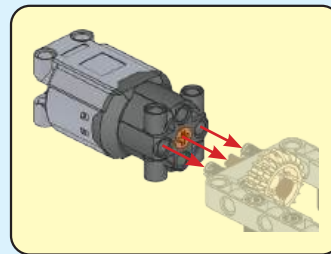

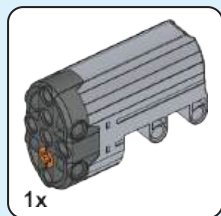

238

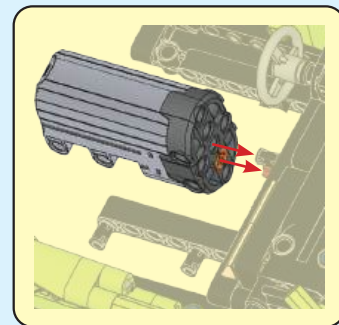
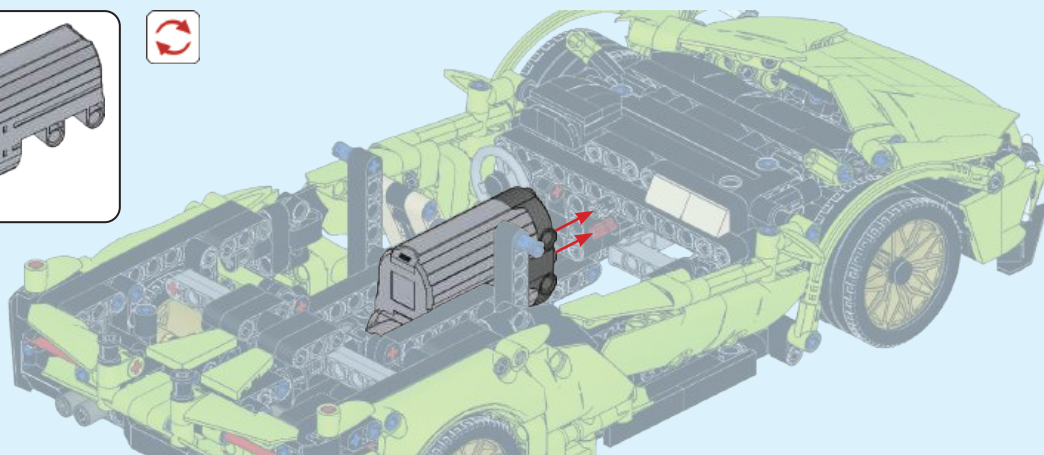

239

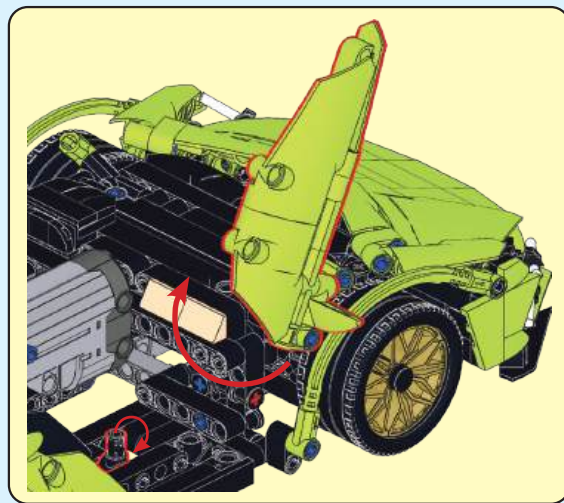
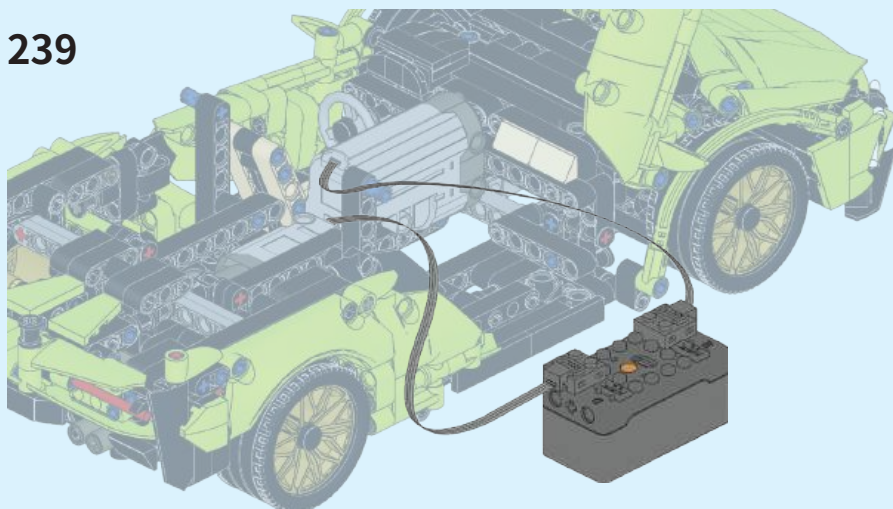

240

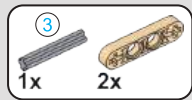
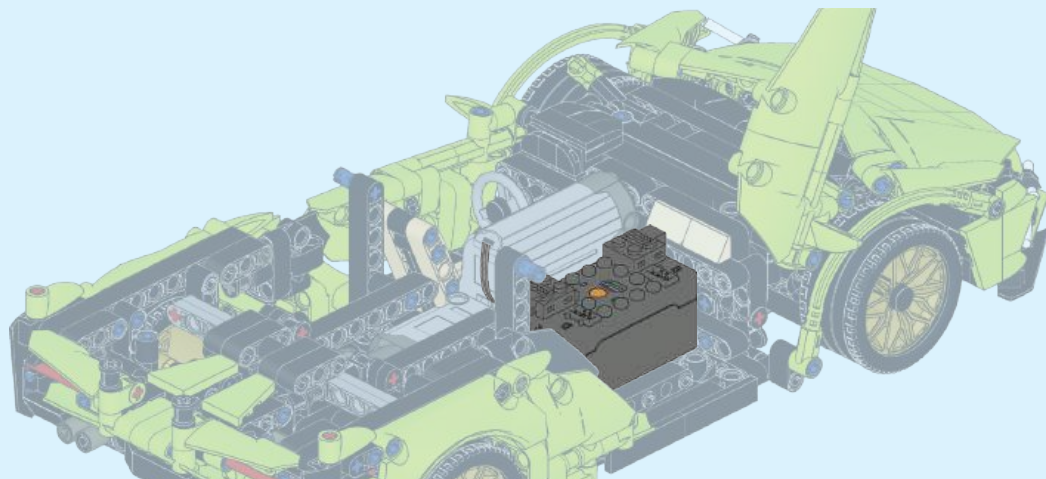

241

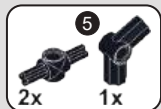
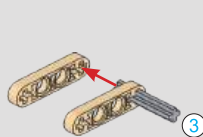

242

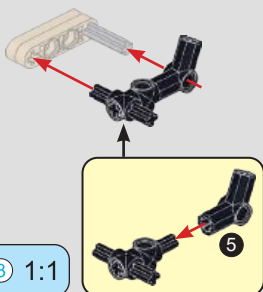

243

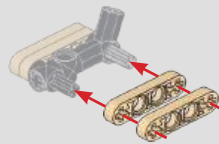

244

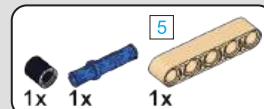
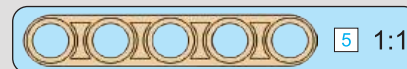
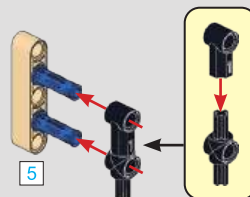

245

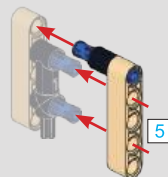



246

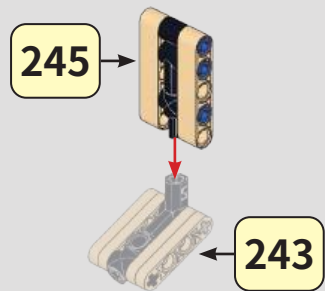

247

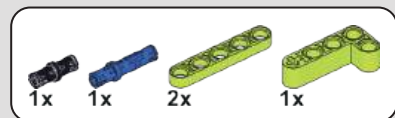
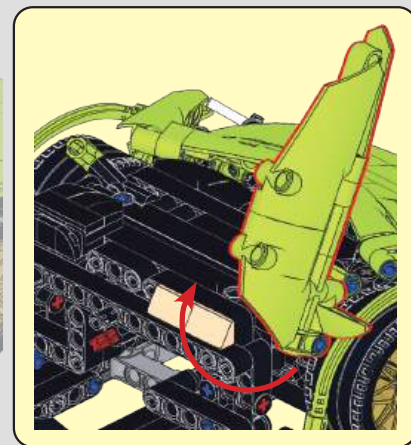
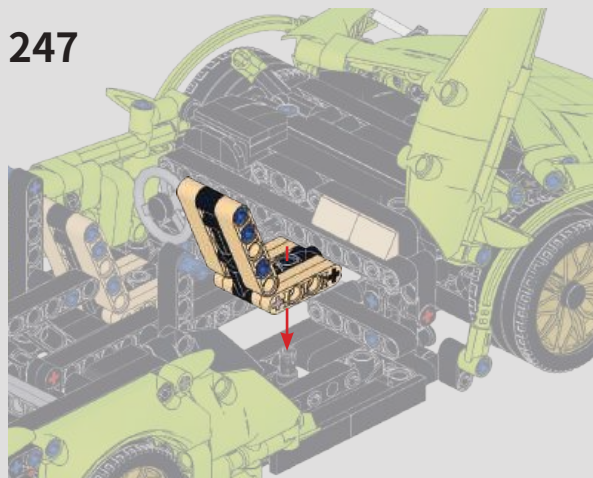

248

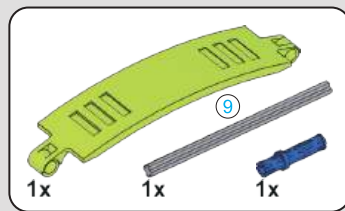
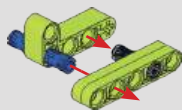

249

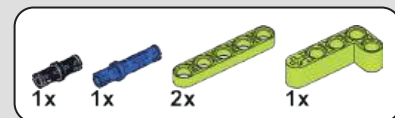
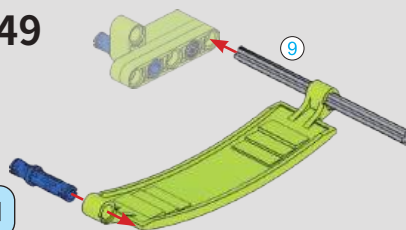

250

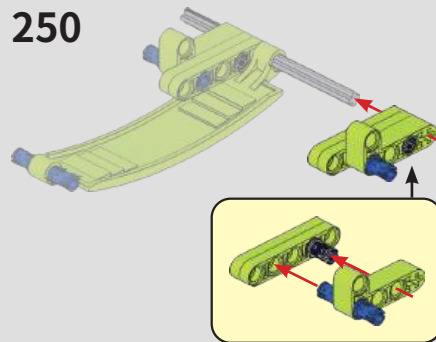

40

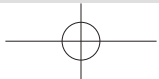
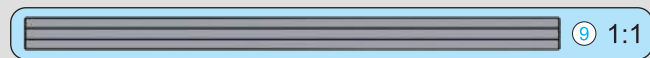



251

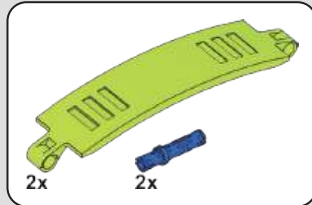
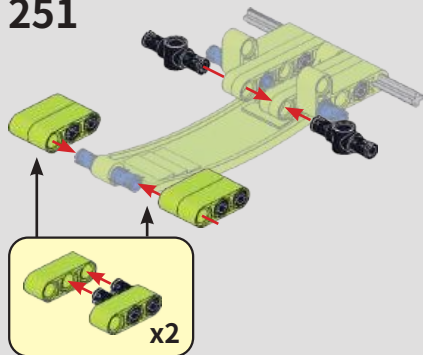

252

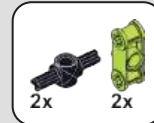
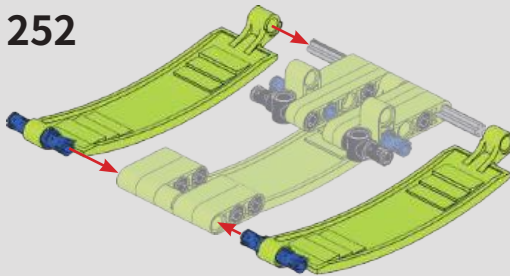

253

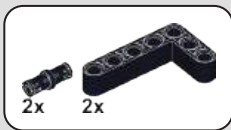
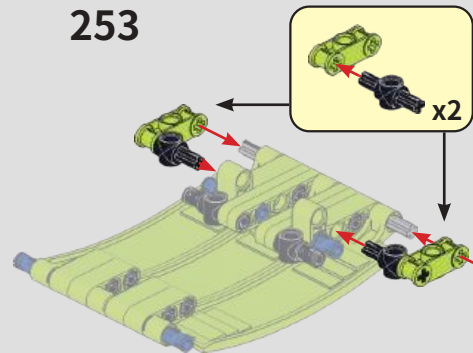

254

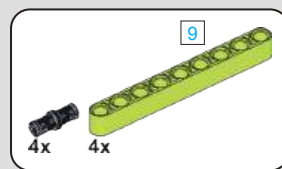
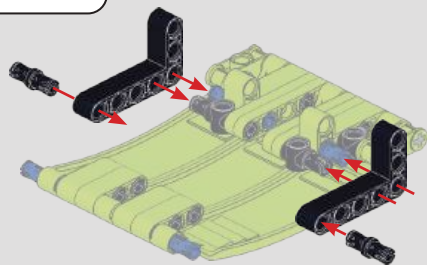

255

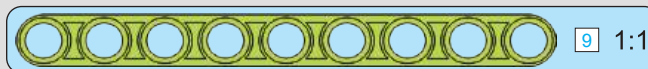
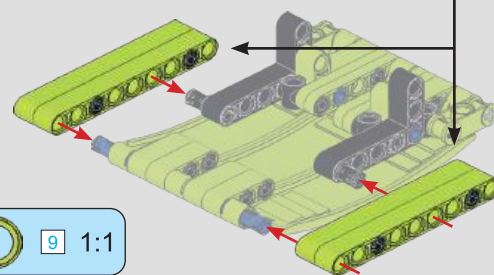
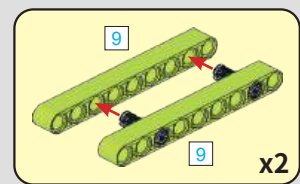

41

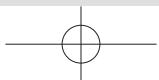



256

255

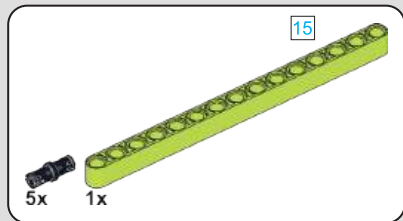
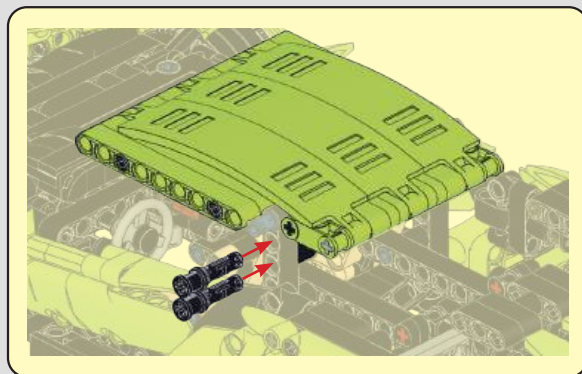
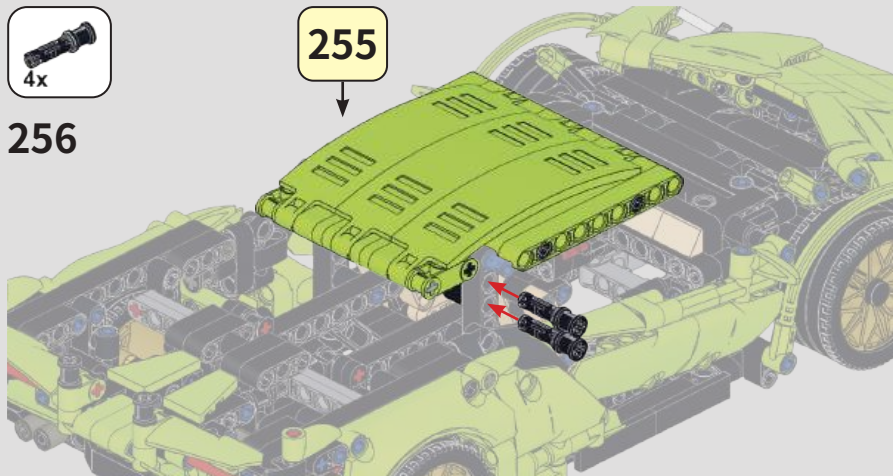

257

42

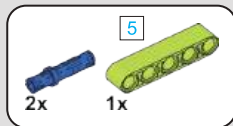

258

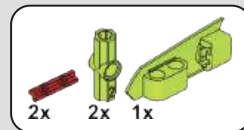

259

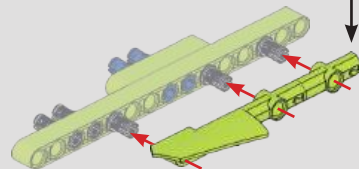
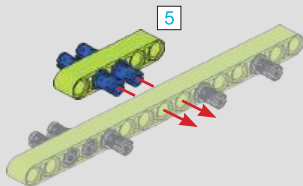
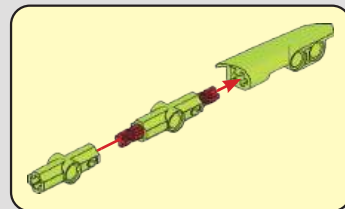



2x

260

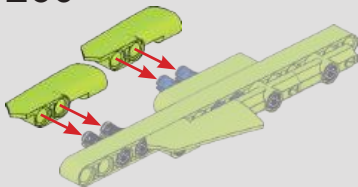

261

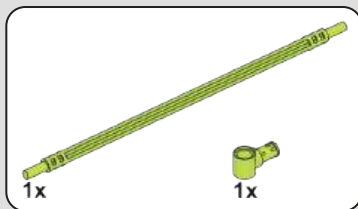
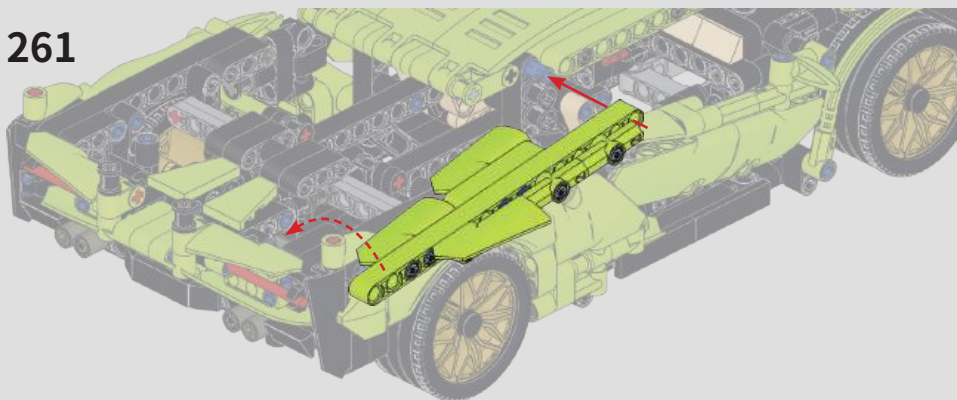

1x

1x

262

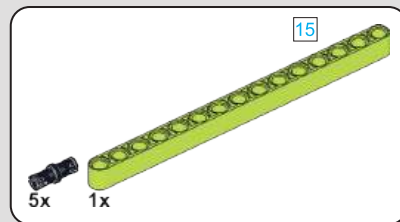
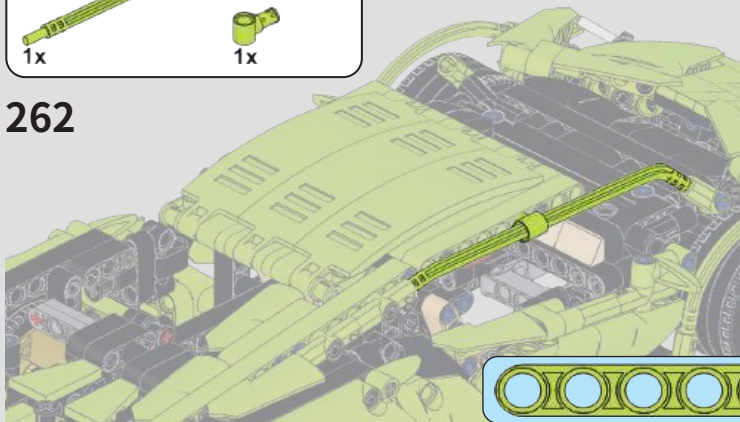

15

5x

1x

263

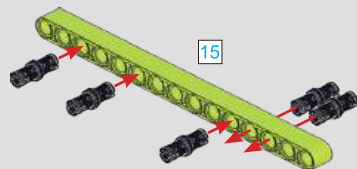

15

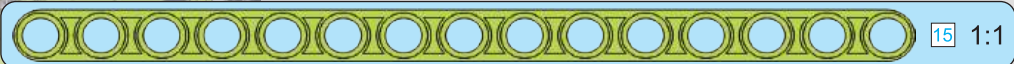

15

1:1

43

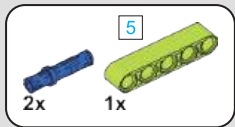

264

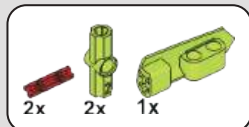
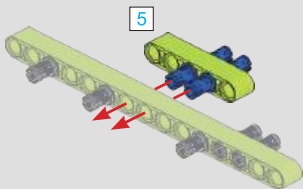

265

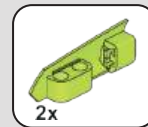
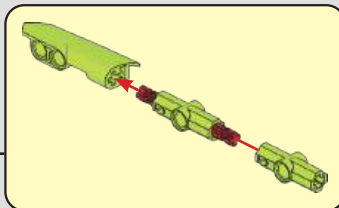
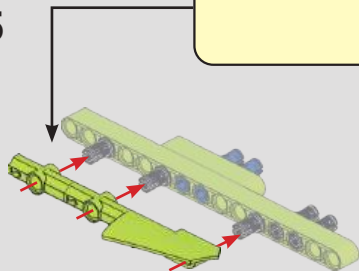

266

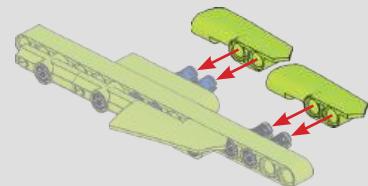

267

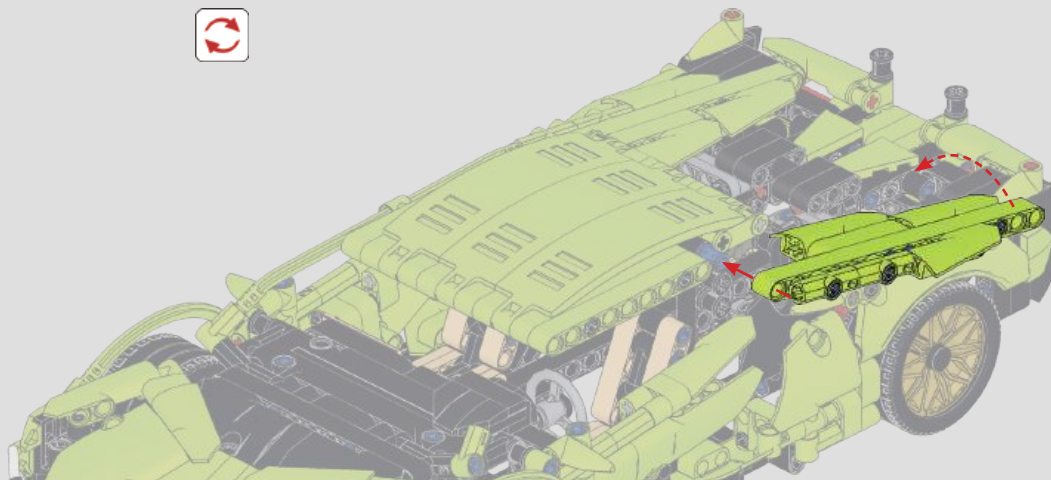

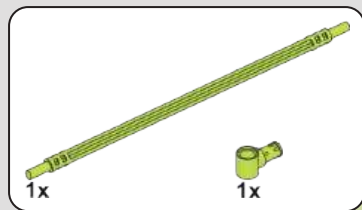

268

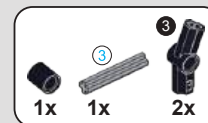
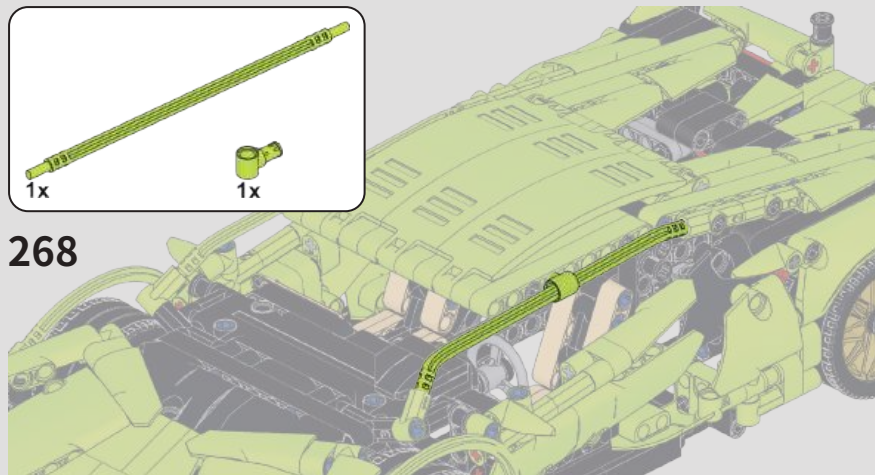

269

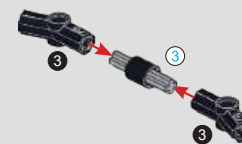

270

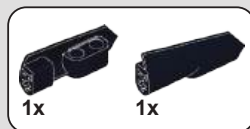
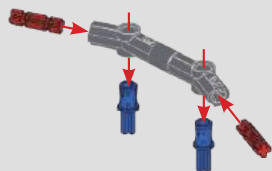

271

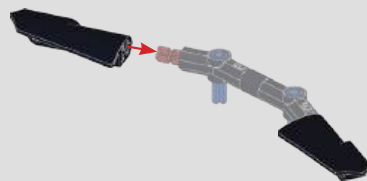

272

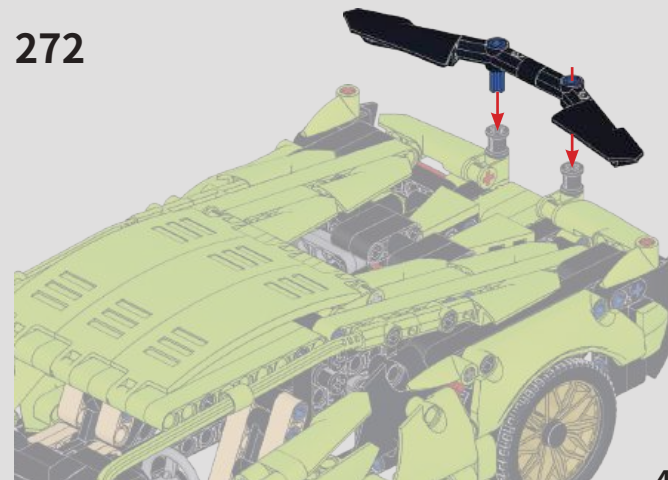

45

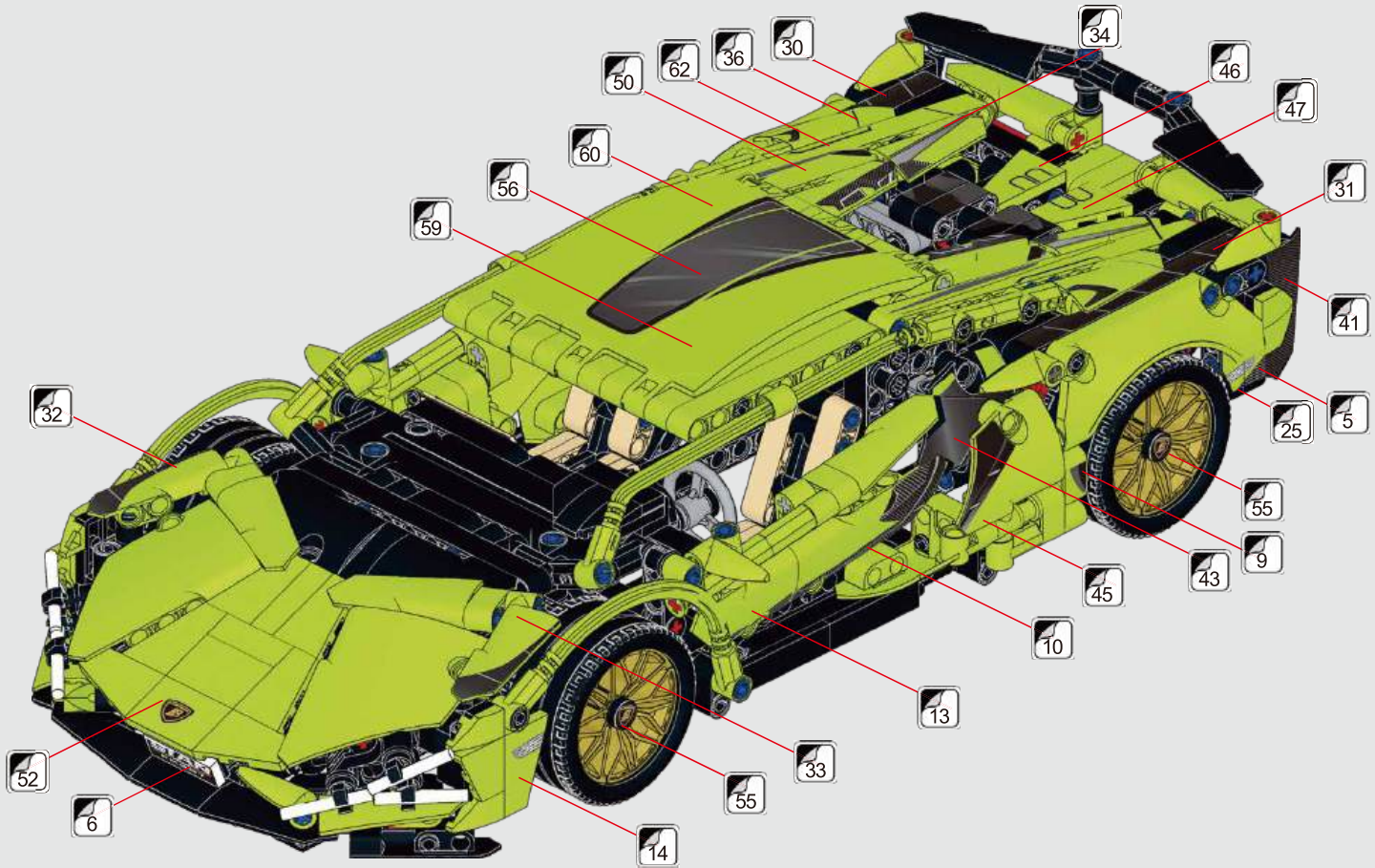

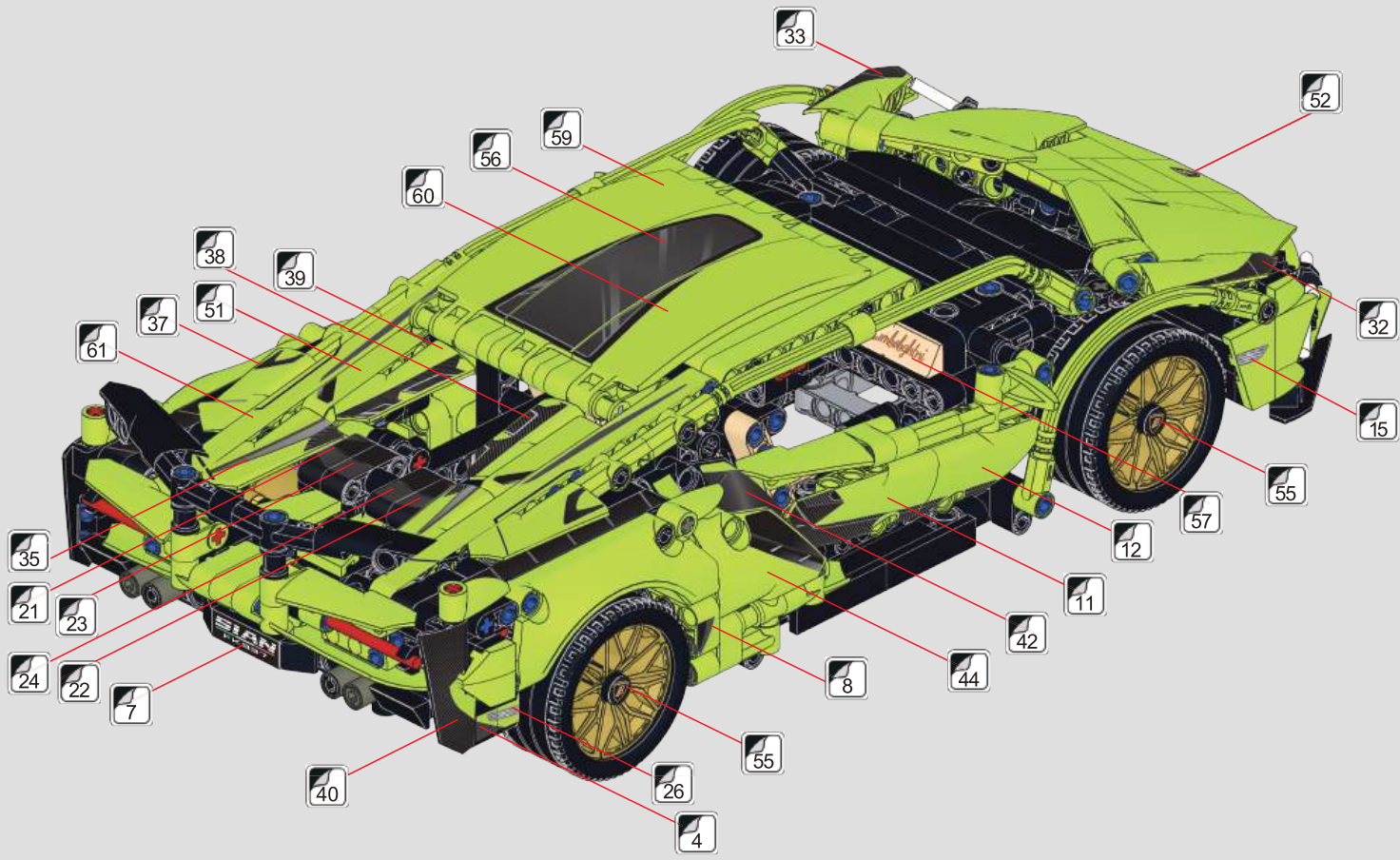



Note: The blue page shows the installation steps of the power version / **Uwaga:** niebieska strona pokazuje kroki instalacji wersji zdalnej / **Poznámka:** Modrá stránka s kroki vzdialenejšej inštalácie / **Poznámka:** Modrá stránka s kroky vzdalenejši instalace

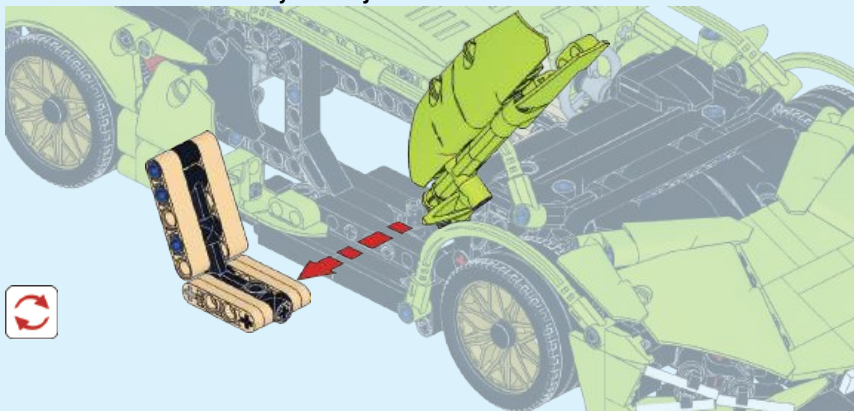

The seat needs to be slightly steered before it can be pulled out / Fotelik należy lekko obrócić, zanim będzie można go wyciągnąć / Pred vyťahnutím je potrebné sedadlo mierne natočiť / Před vytažením je třeba sedadlo mírně natočit

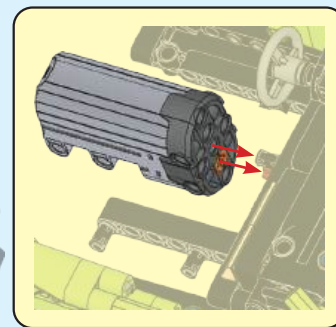
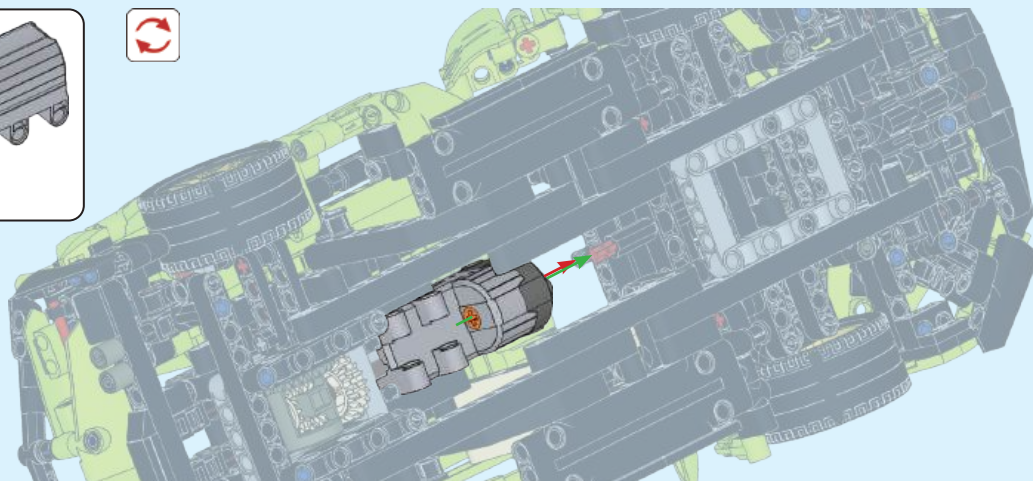
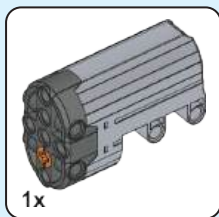

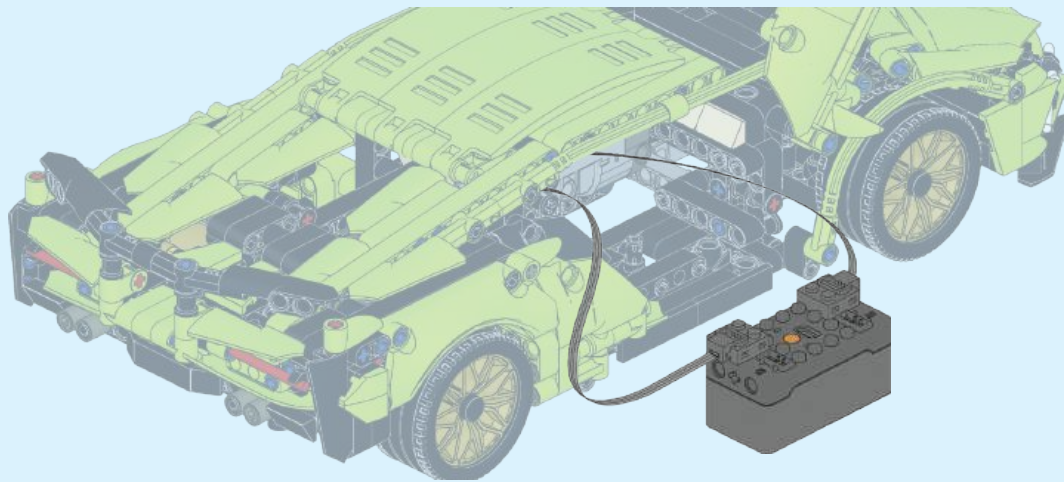
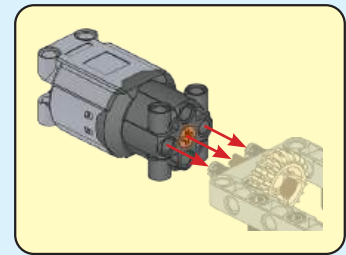
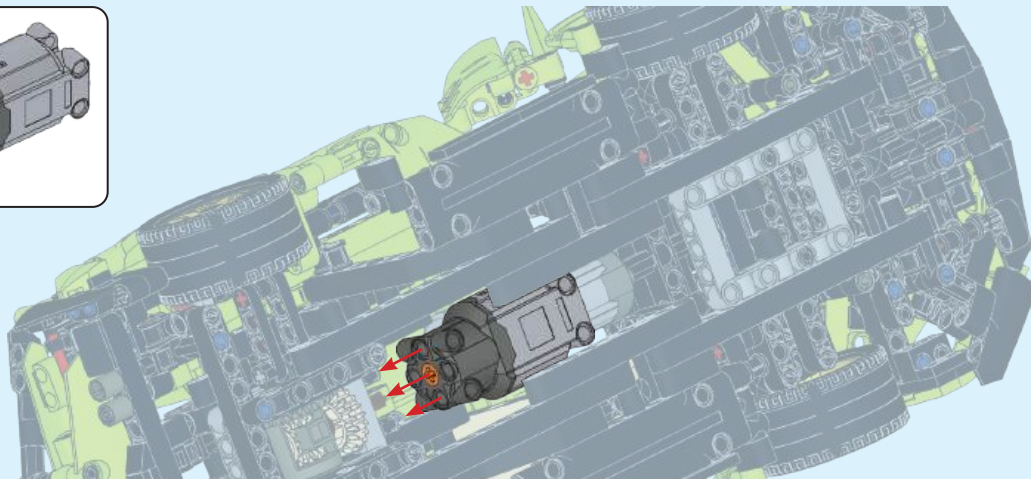
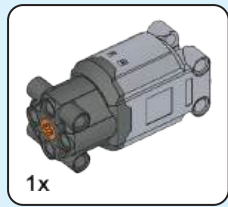



LANBORGINI FK937 1:14



20230909.05

