



# CYBERPUNK

## 搭建指南

BLOCK RACING



E





## Instruction Manual Tips / Wskazówki dotyczące instrukcji obsługi / Tipy v návode na použitie / Tipy v návodu k použití

- 1** Open the numbered bags according to the instructions / Otwieraj ponumerowane woreczki zgodnie z instrukcją / Otvorte očíslované vrecká podľa pokynov / Otvorte očíslované sáčky podle návodu

Bag G and unnumbered bags should be opened first / Woreczek G oraz woreczki nieponumerowane należy otworzyć na początku / Vrecko G a nečíslované vrecia by sa mali otvoriť ako prvé / Sáček G a nečíslované sáčky by měly být otevřeny jako první

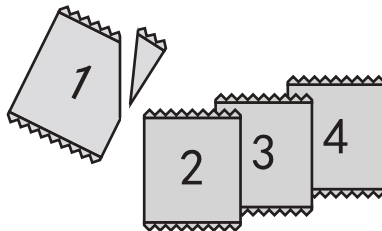
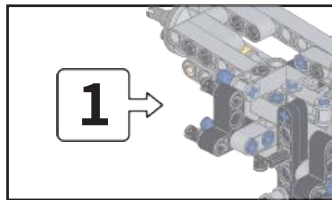

- 2** Use the 1:1 legend to quickly find parts of the right length / Użyj legendy 1:1, aby szybko znaleźć części o odpowiedniej długości / Použite legendu 1:1 na rýchle nájdenie častí správnej dĺžky / Použijte legendu 1:1 k rychlému nalezení částí správné délky

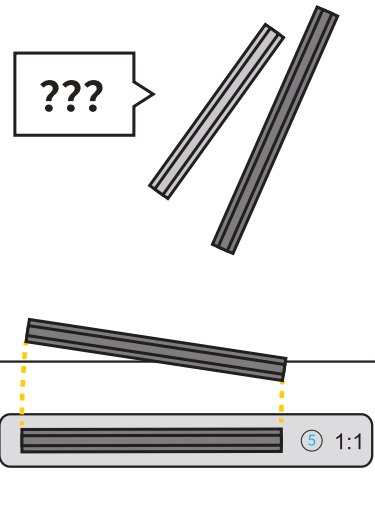

- 3** The meaning of the icons in the instruction manual / Znaczenie ikon w instrukcji obsługi / Význam ikon v návode na použitie / Význam ikon v návodu k použití



Rotate the structures / Obróć konstrukcje / Otočte štruktúry / Otočte struktury



The number indicates the corresponding sticker number / Liczba wskazuje odpowiedni numer naklejki / Číslo označuje príslušné číslo nálepky / Číslo označuje odpovídající číslo nálepky

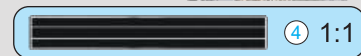
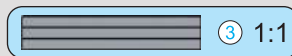
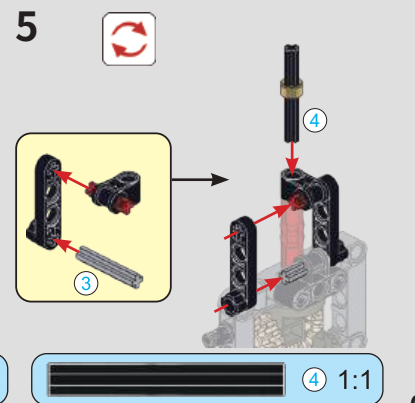
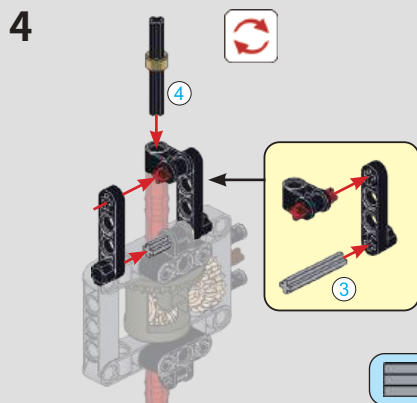
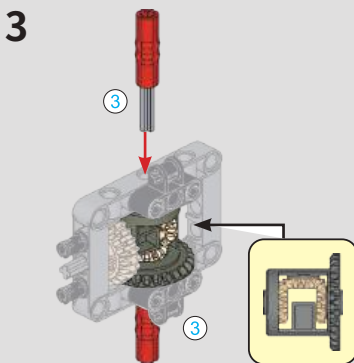
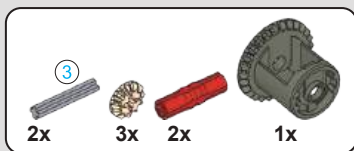
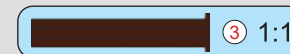
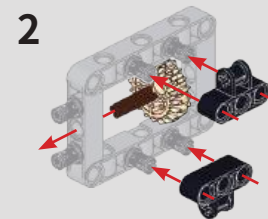
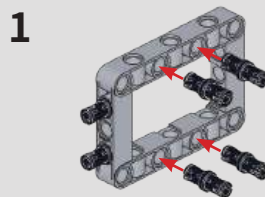
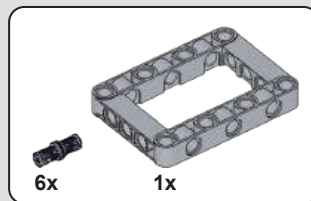
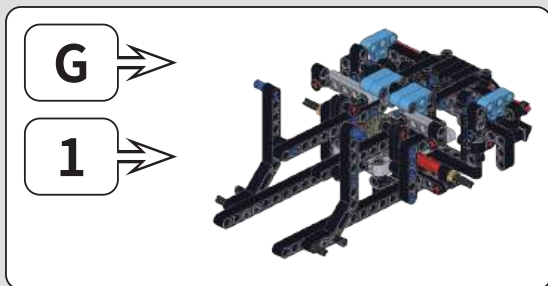



6

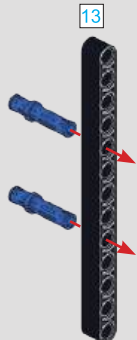

7

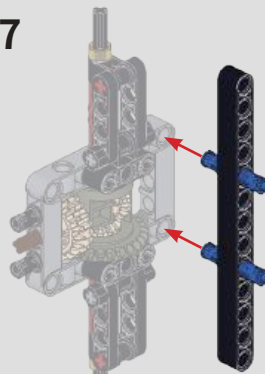

8

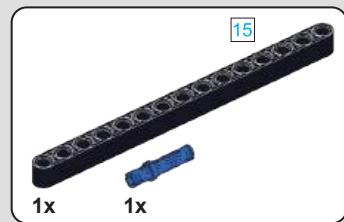
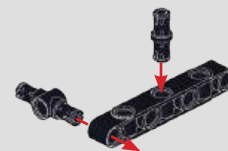

9

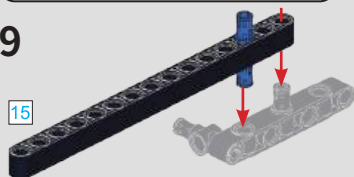

10

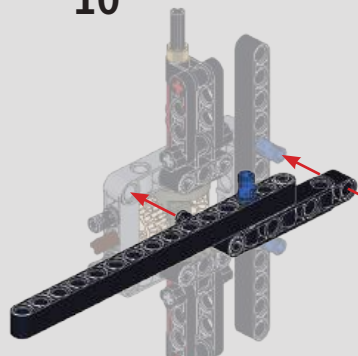

11

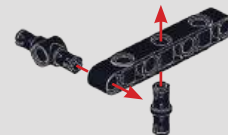

02



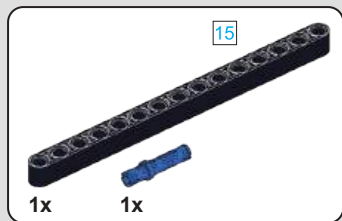

12

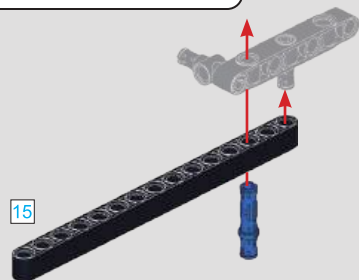

13

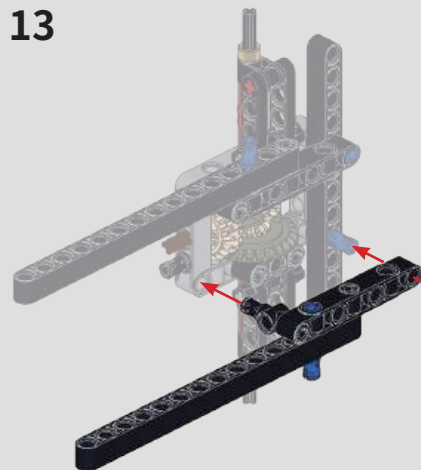

14



15

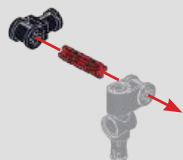

16

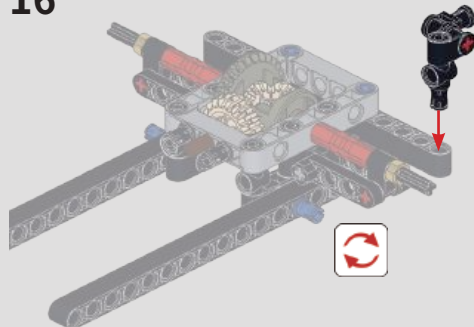

17



18



03

19

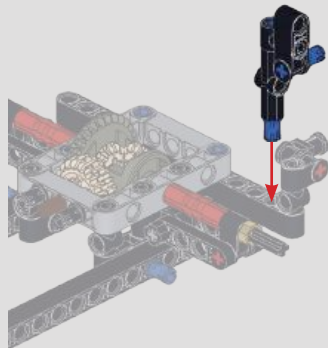

20

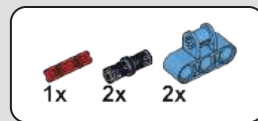
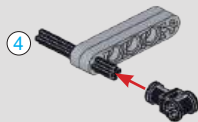

21

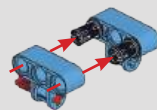

22

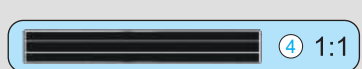
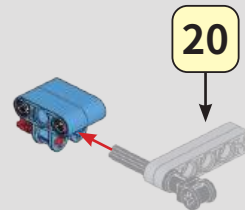

23

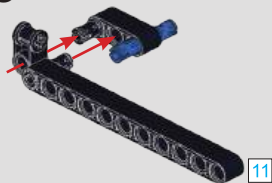

24

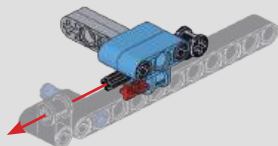

25

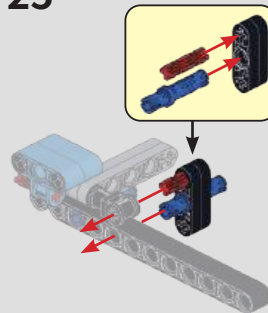

26

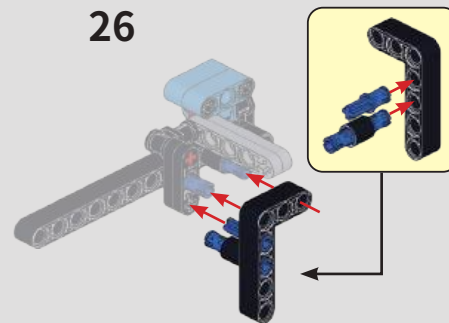

04



27

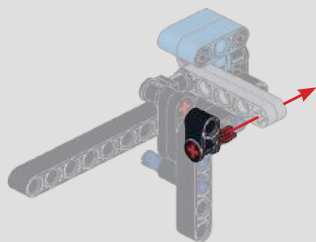

28

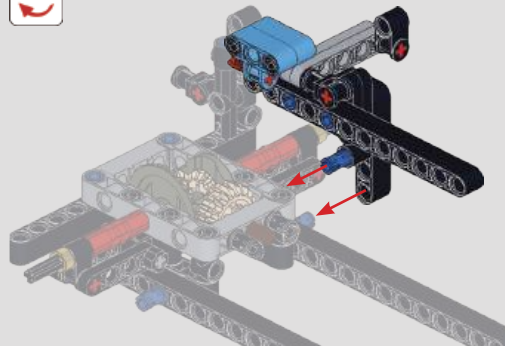

29



30

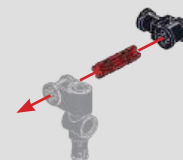

31

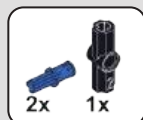
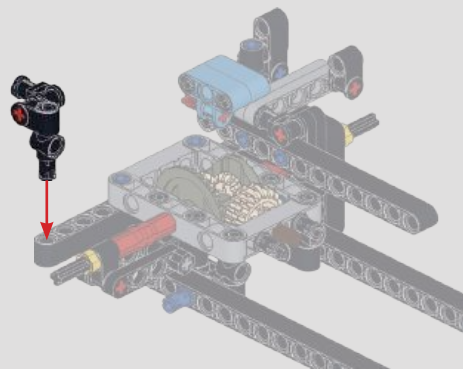

32



33

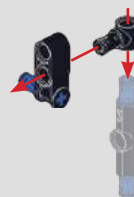

34

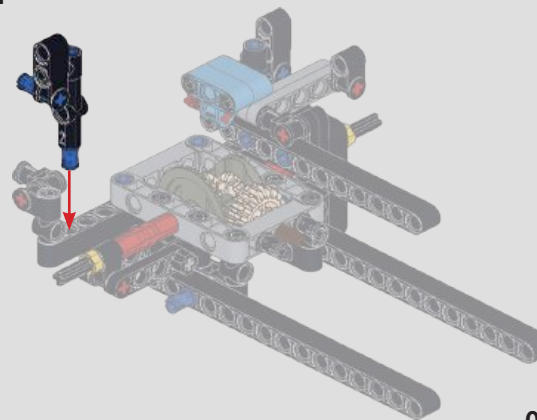

05



35

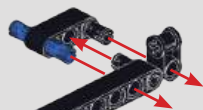

11



36

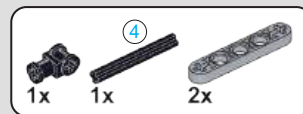
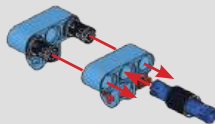

37

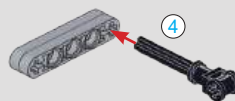

38

36

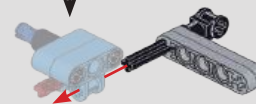

39

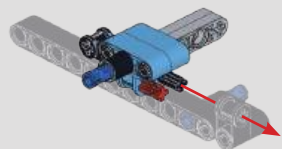

40

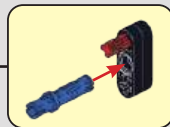
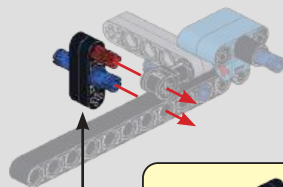

41

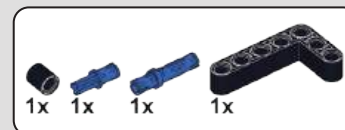
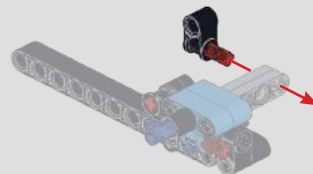

42

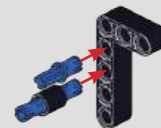

06







43

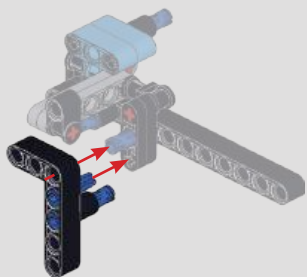

44

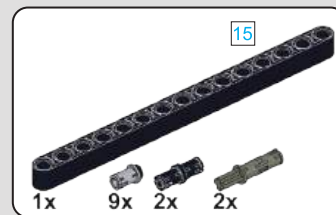
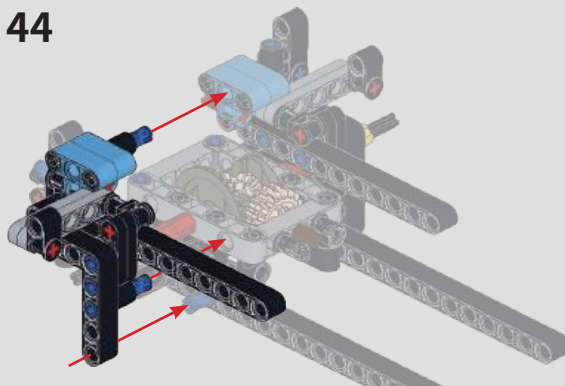

45

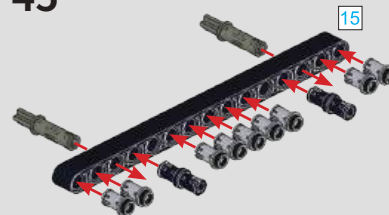

46

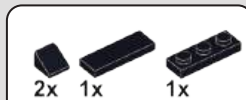
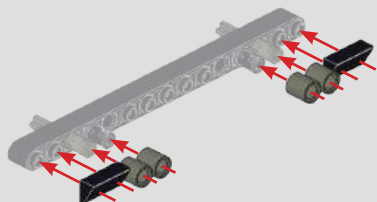

47

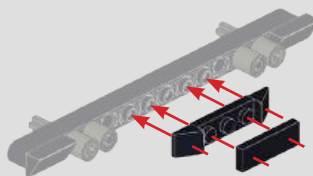

48

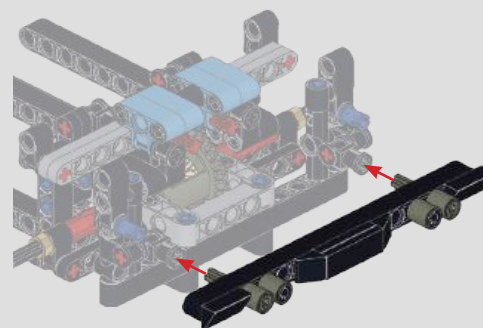

07

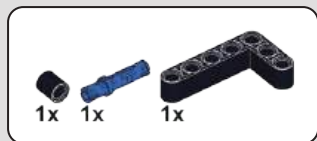

49

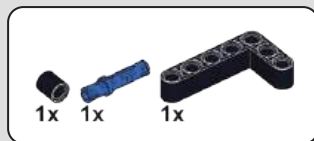
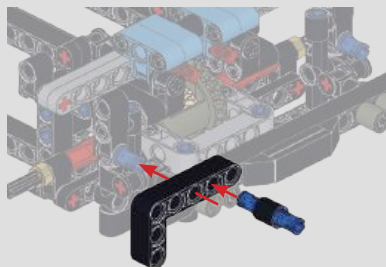

50

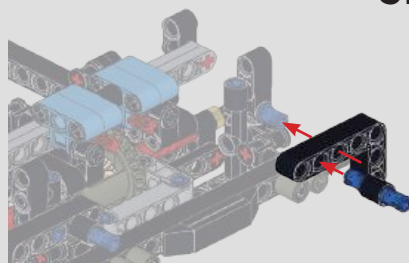

51

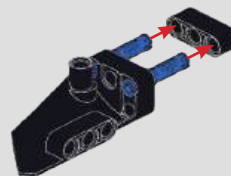

52



53

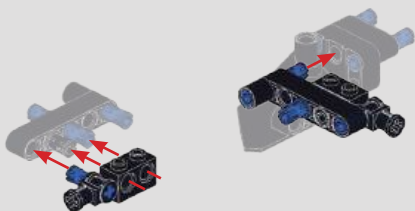

54



55

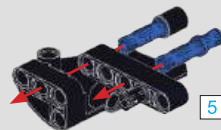

56

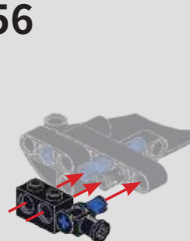

57

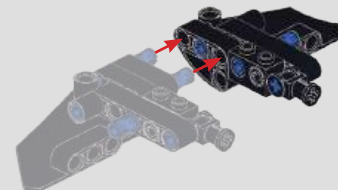



58

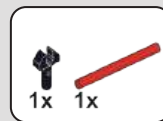

61

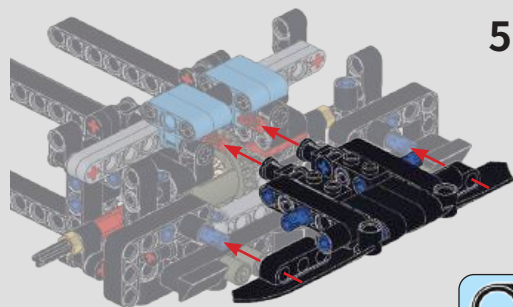

59

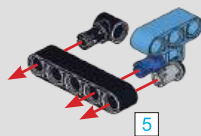

60

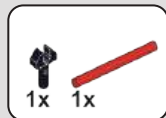
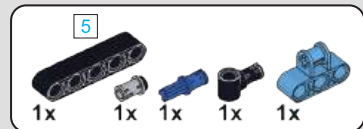
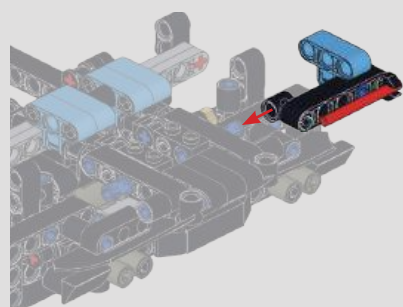
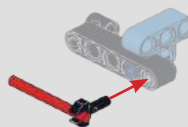

64

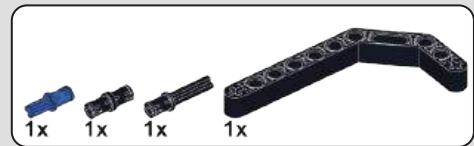

62

63

65

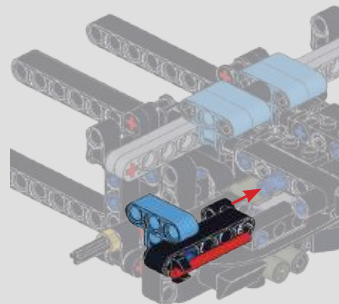
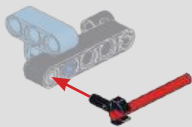
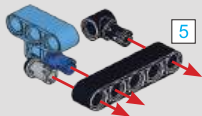



66

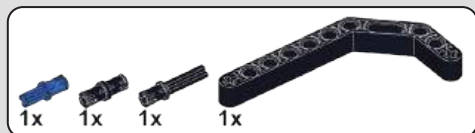
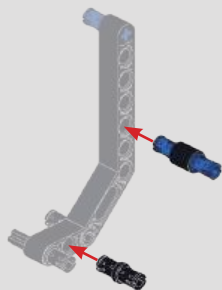

67



68

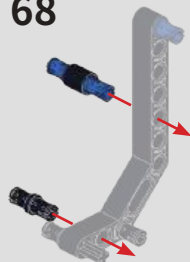

69

66

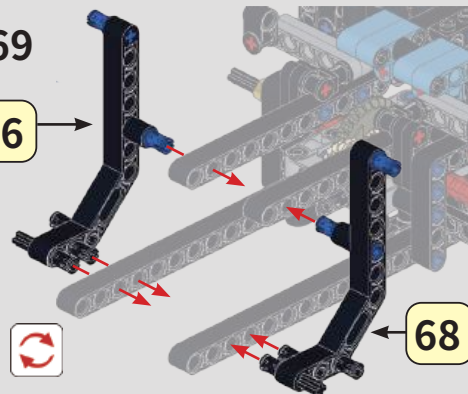

68

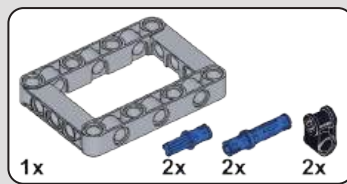
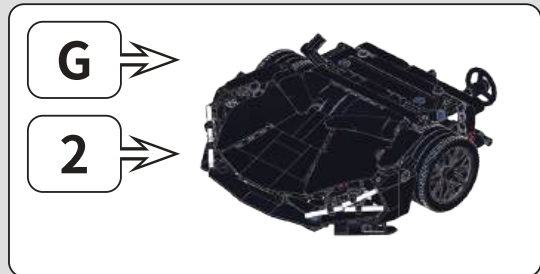

70

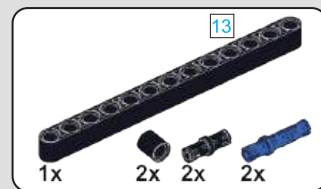
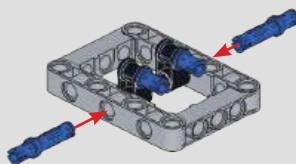

71

13

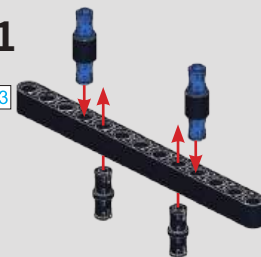



73

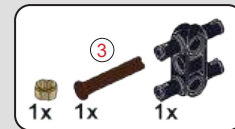

72

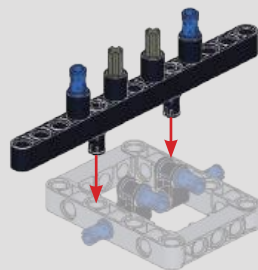
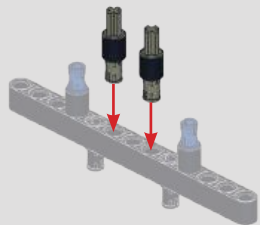

74

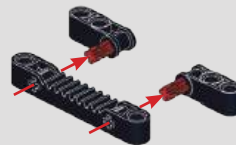

75

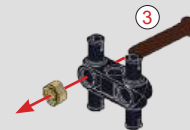

76

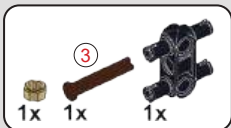
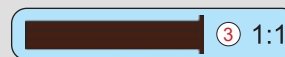

79

80

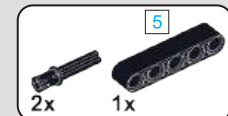

77

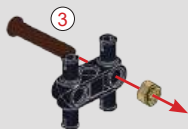

78

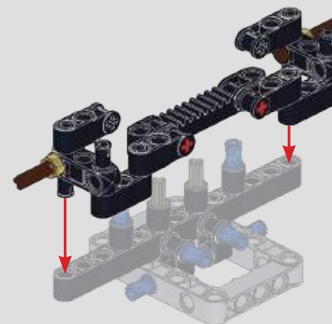
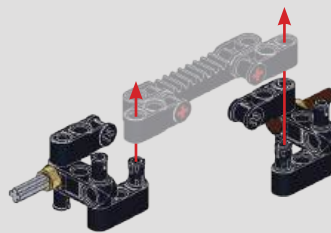

81



11



82

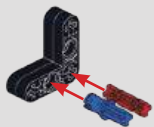

83

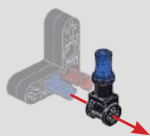

84



85

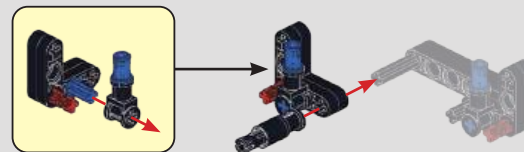

86

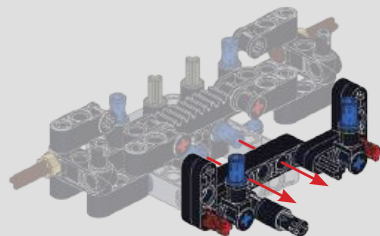

87

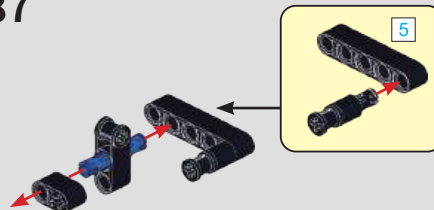

88

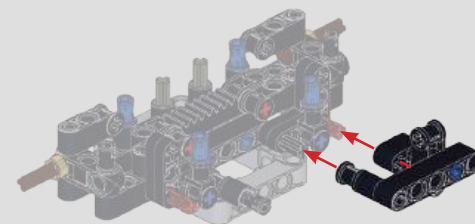

12





89

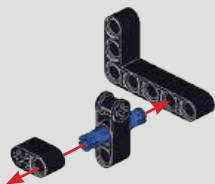

90

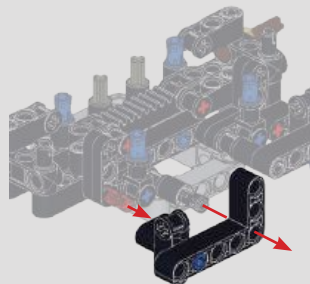

91

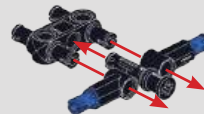

92

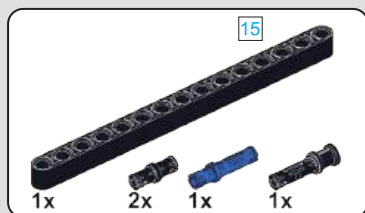
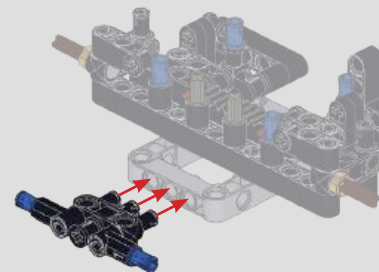

93

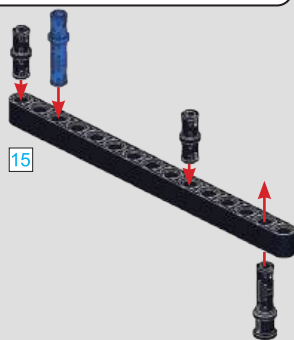

94

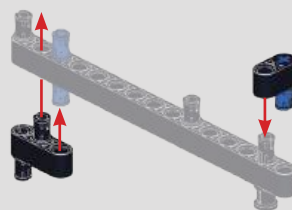

95

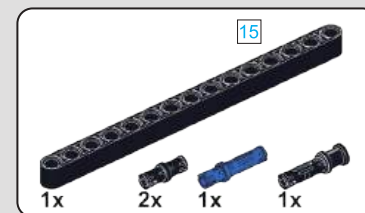
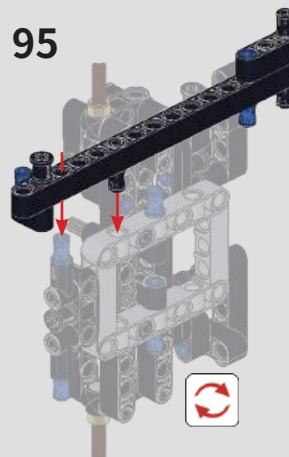

96

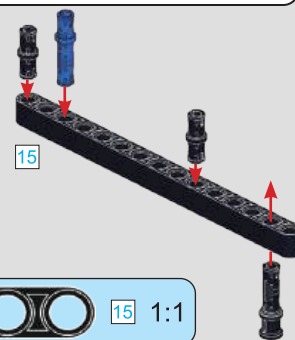

13

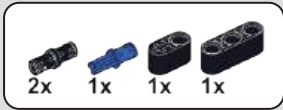

97

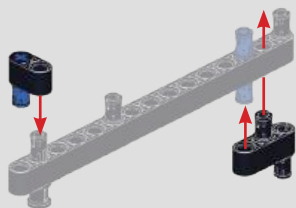

98

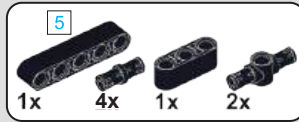
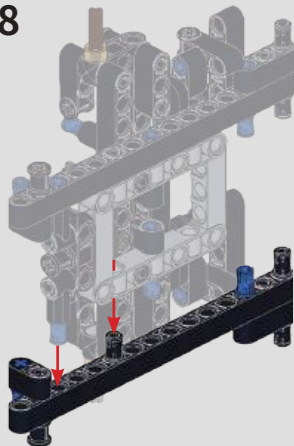

99

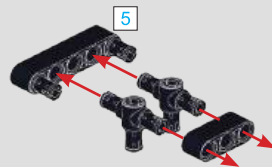

100

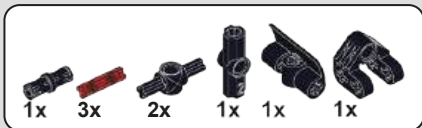
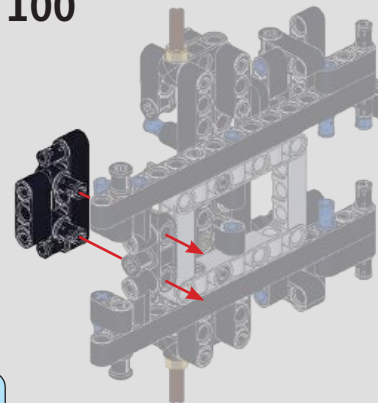

101

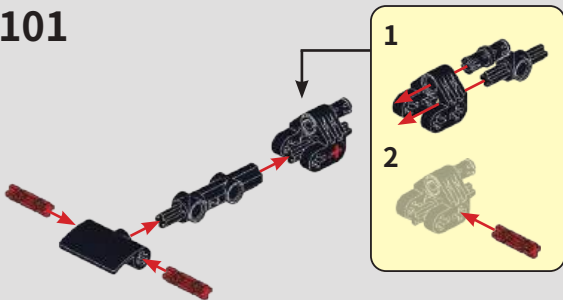

14

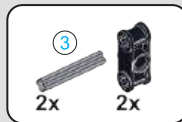

102

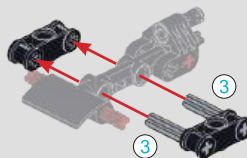

103

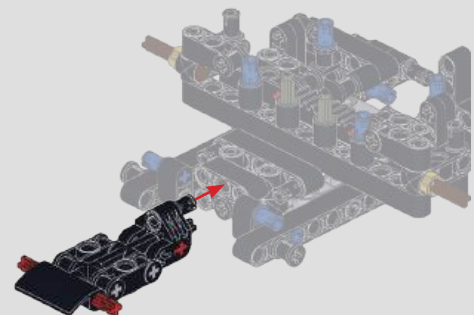





104

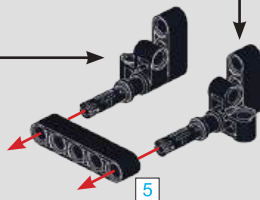
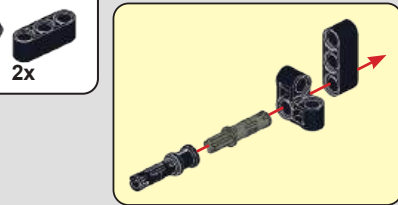
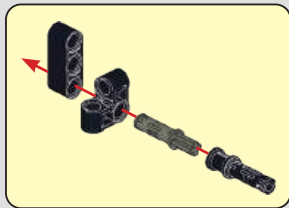

105

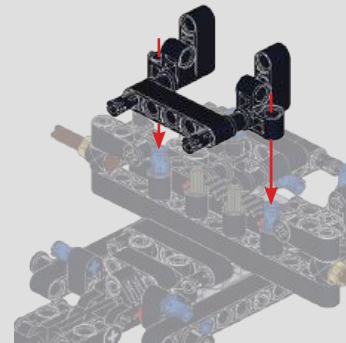

106

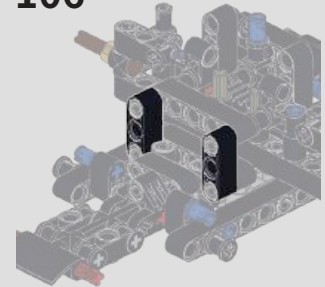

107

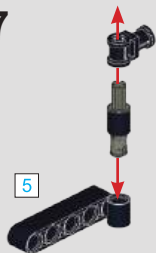

108

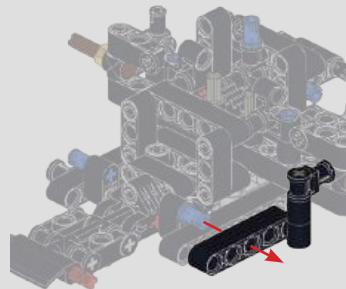

109

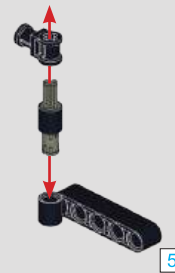

110

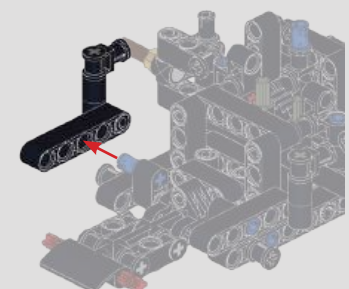



111

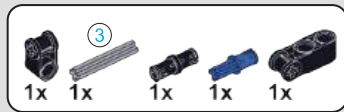
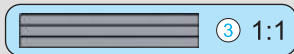
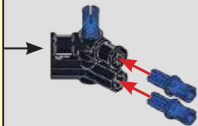

112



113

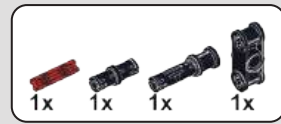

114

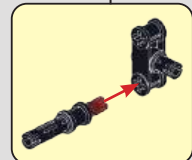

115



116

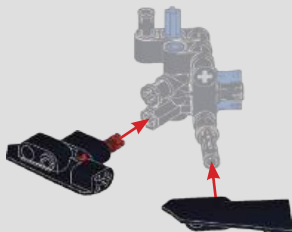

117



118

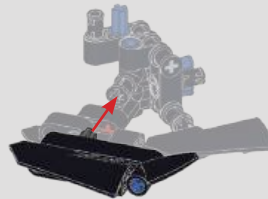

119

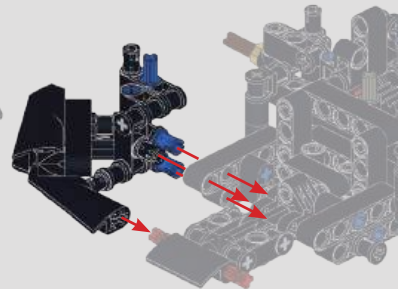

16





120

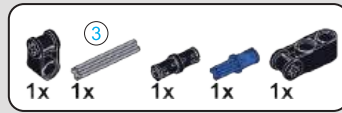
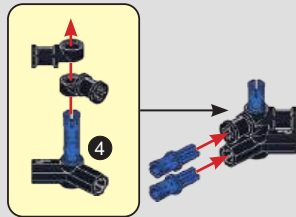

121

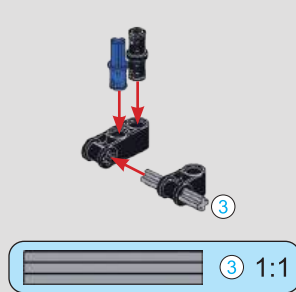

122

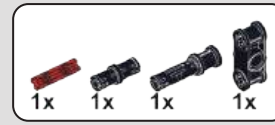

123

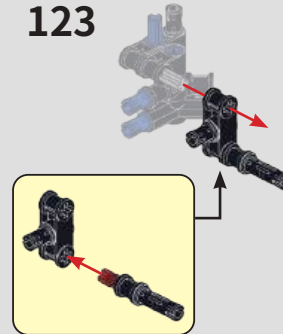

124



125

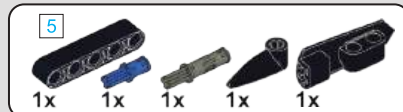
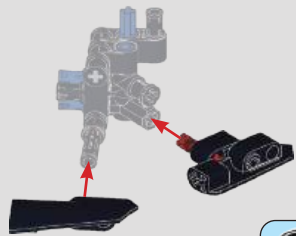

126

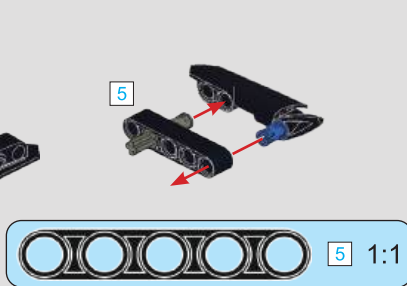

127

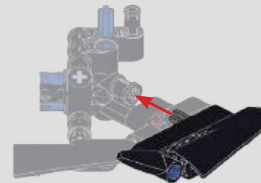

128

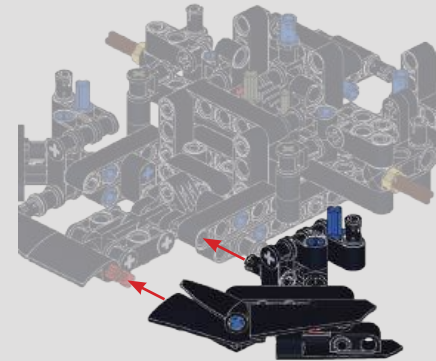



129

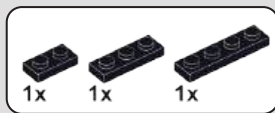

130

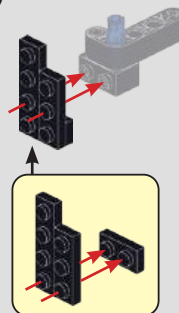

131

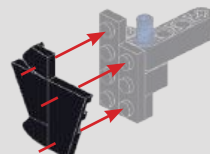

132

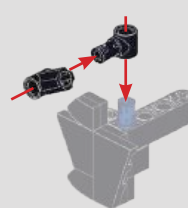

133

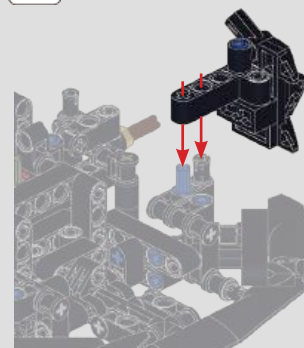

134

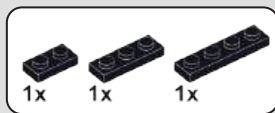
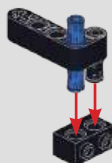

135

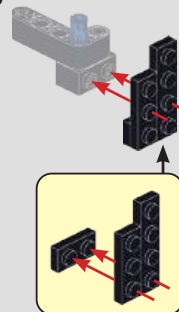

136

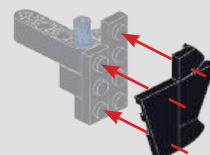

137

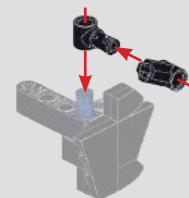

138

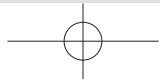
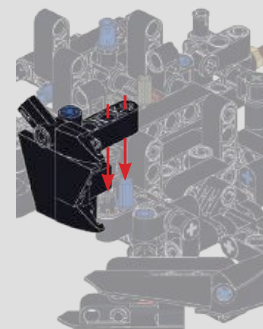

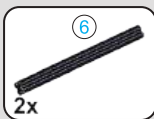

139

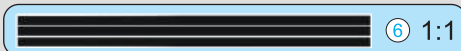
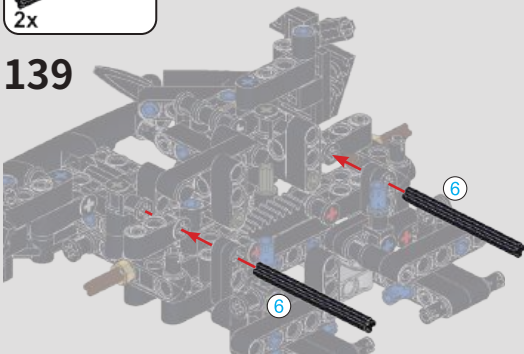

140

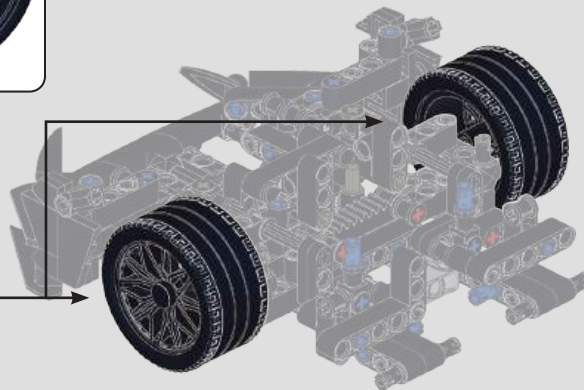
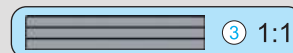
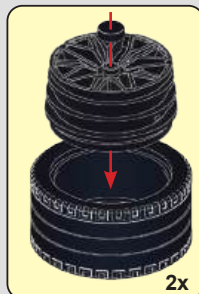

141

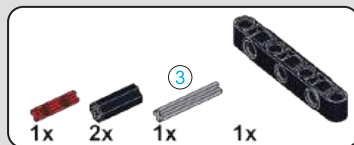
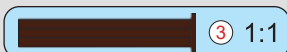
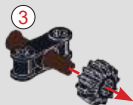

142

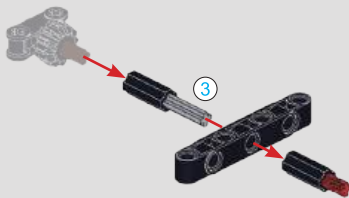

143

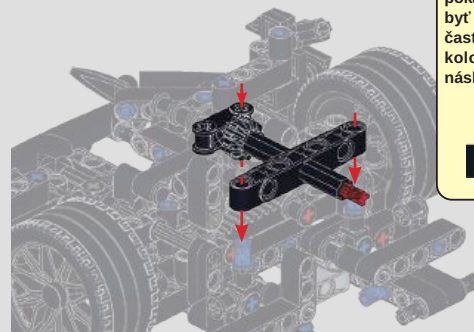

This gear should be placed in the center of the following parts as shown / Przekładnię tę należy umieścić pośrodku następujących części, jak pokazano/ Toto ozubené koleso by malo byť umiestnené v strede nasledujúcich častí, ako je znázornené/ Toto ozubené kolo by mělo být umístěno ve středu následujících částí, jak je znázorněno.





144

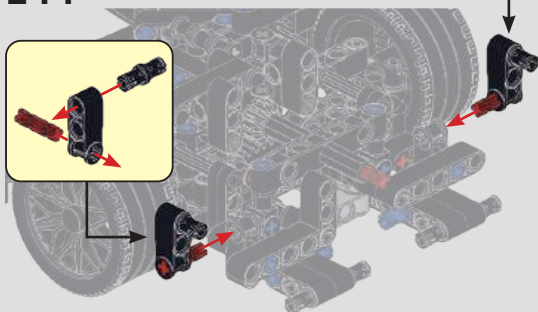

145

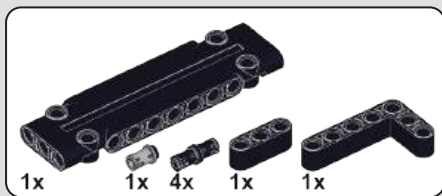
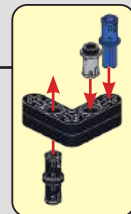
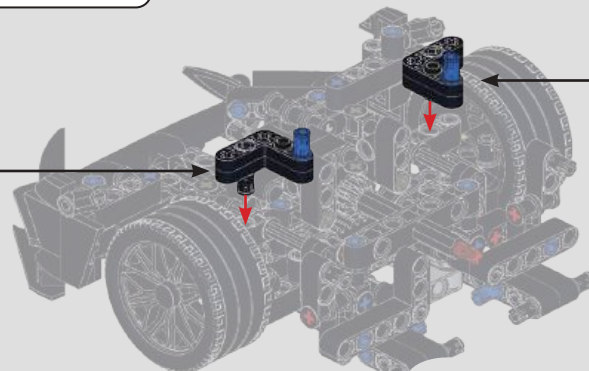
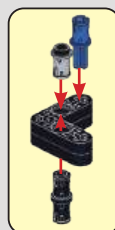

146

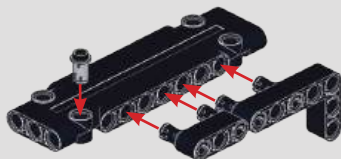

147

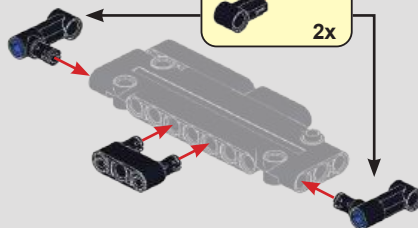
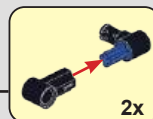

148

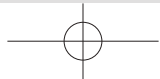
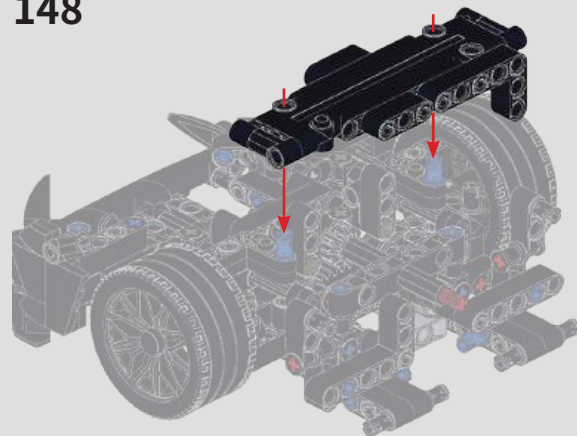

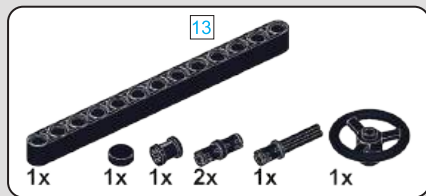

149



150

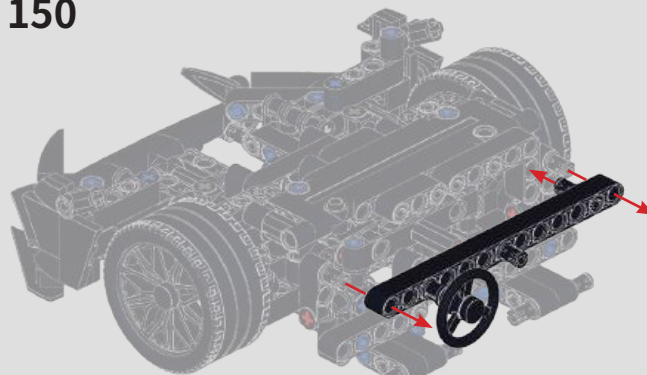

151

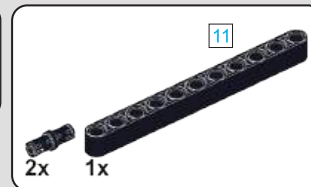
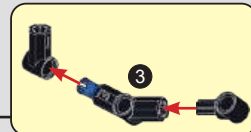
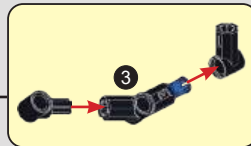
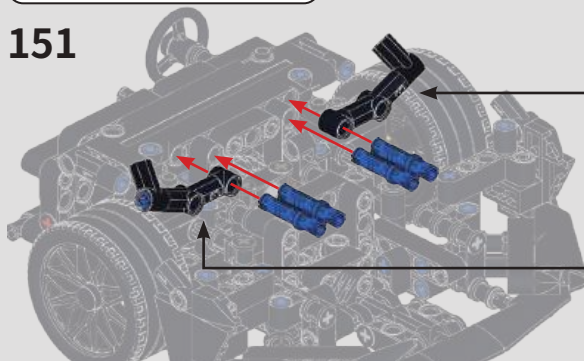

152



21



153

152

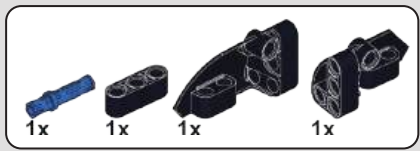
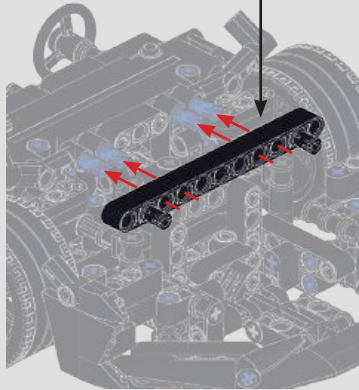

154

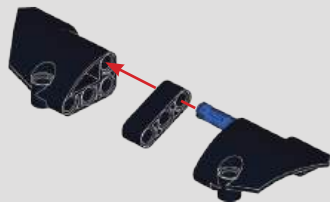

155

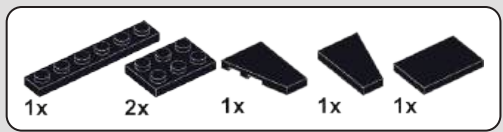
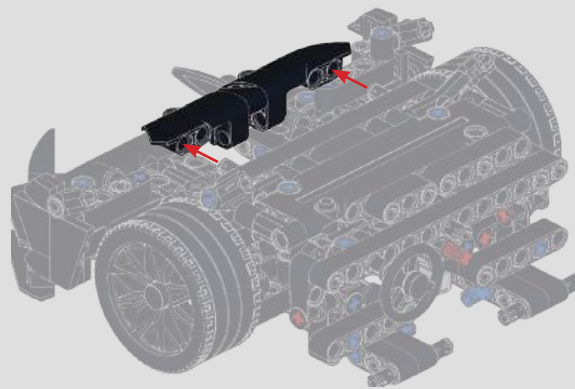

156

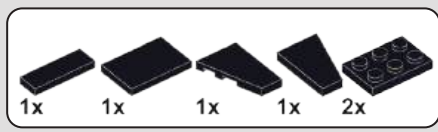
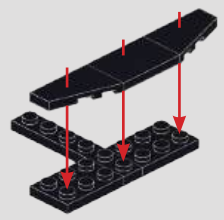

157

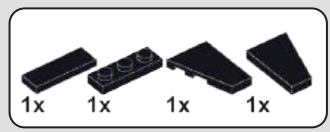
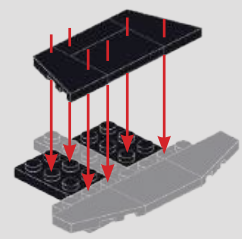

158

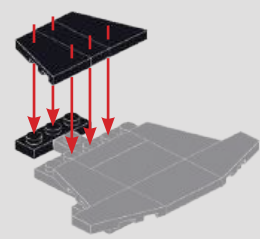



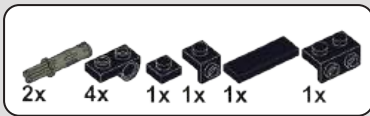

159

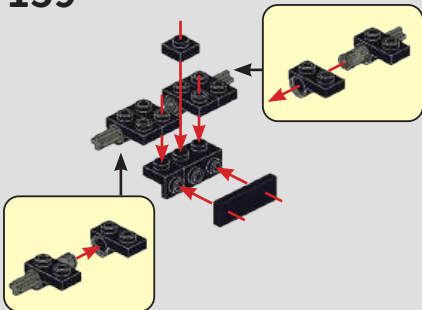

160

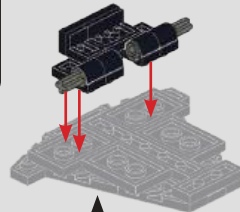

158

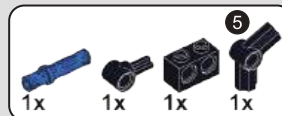

161

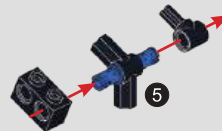

162

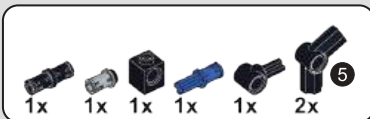
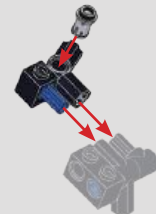

163

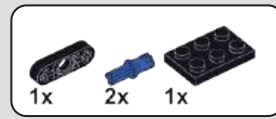
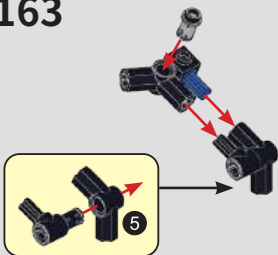

164

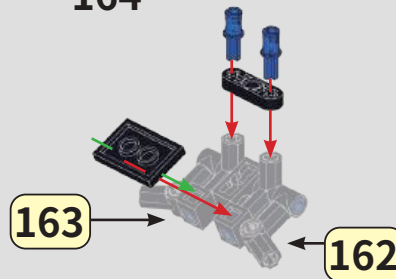

165

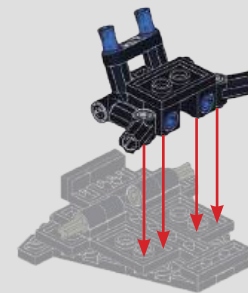

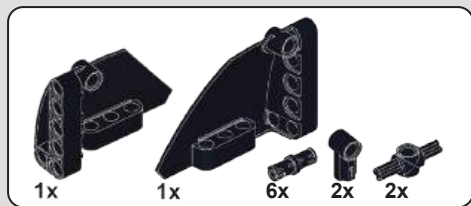

166

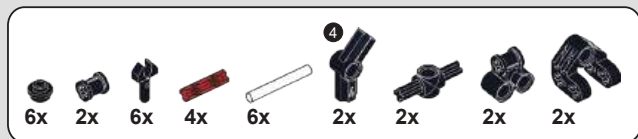
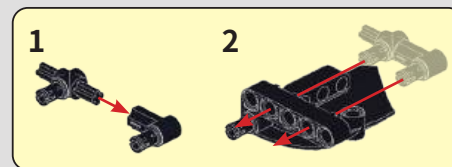
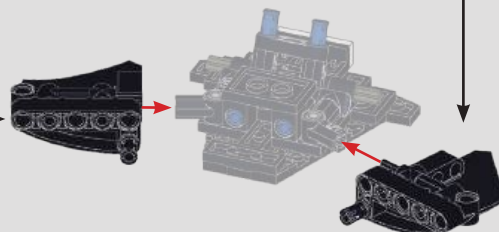
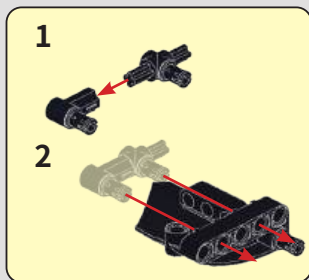

167

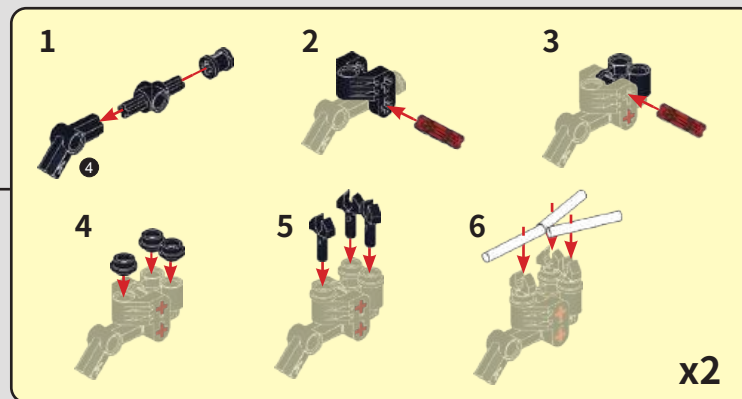
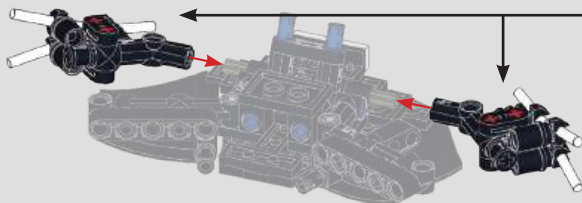

24

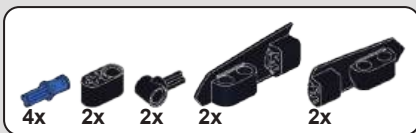

168

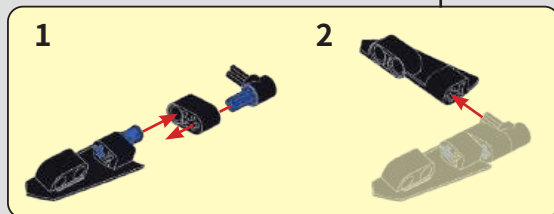
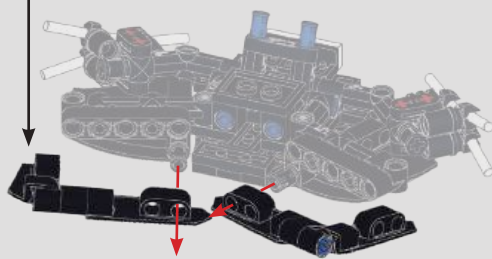
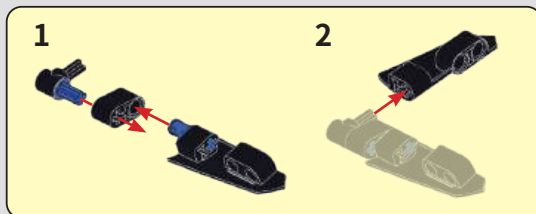

169

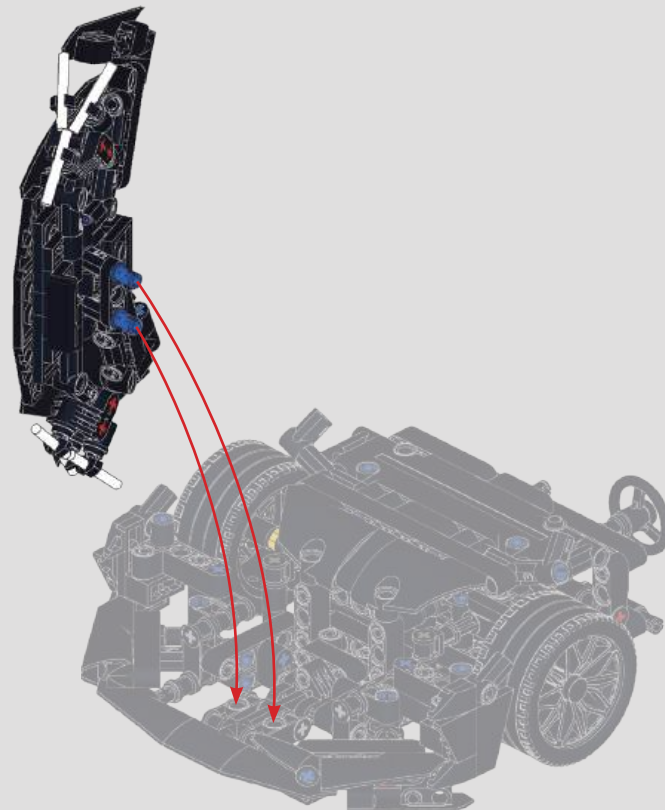

25

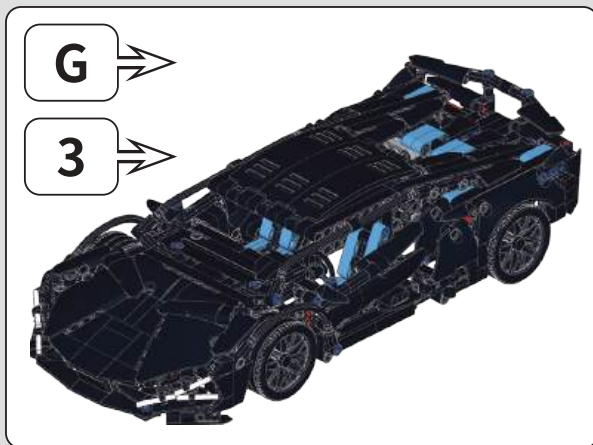

170

169

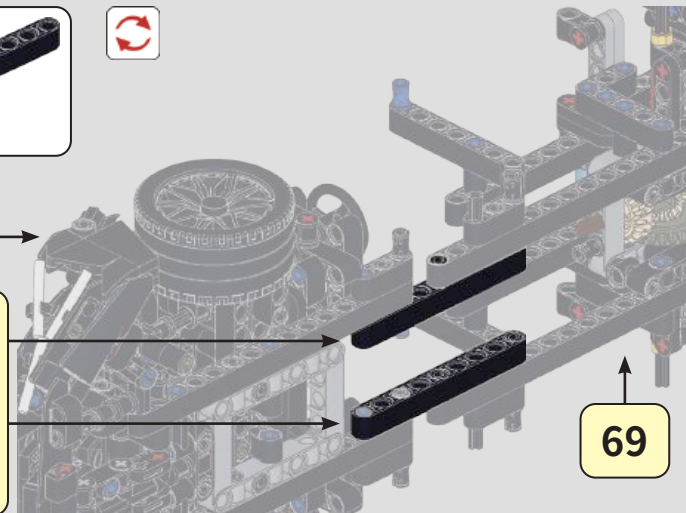
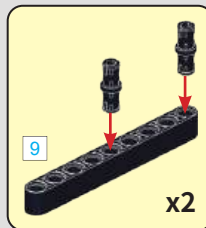

69

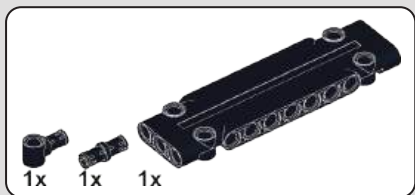

171

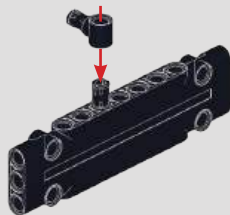

26



172

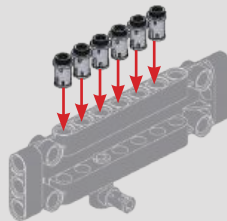

173

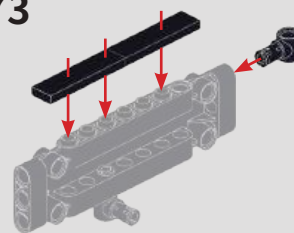



174

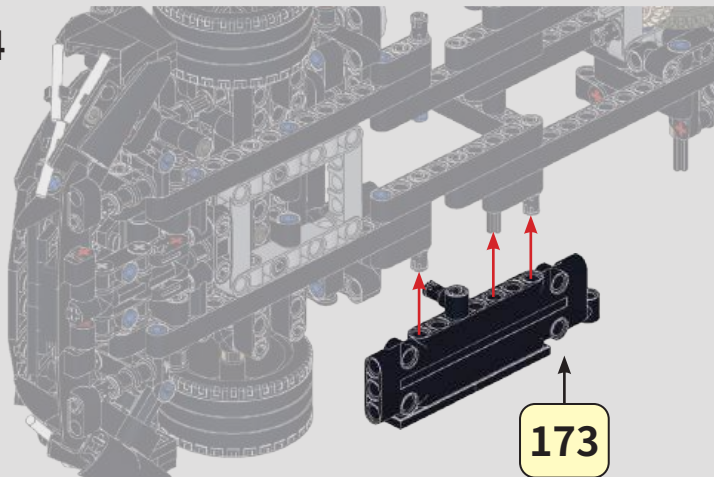

175



176

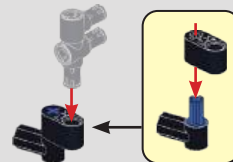

177

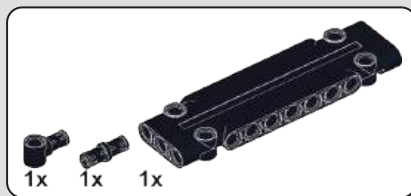
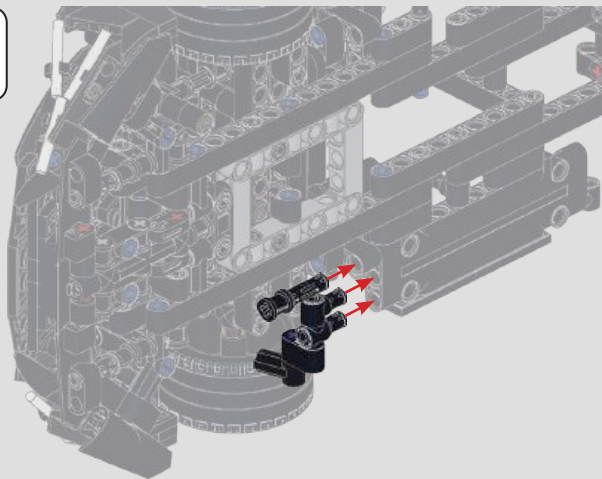

178

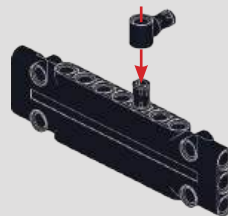

179

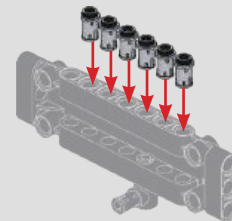



180

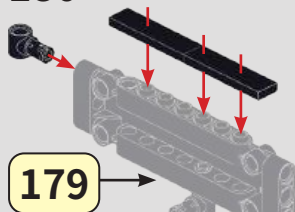

179

181

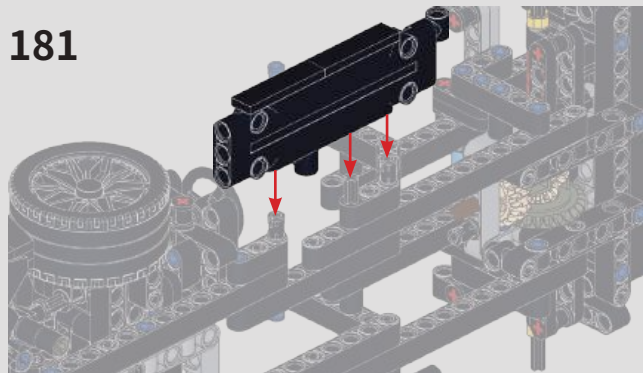

182

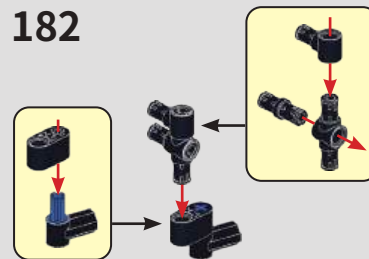

183

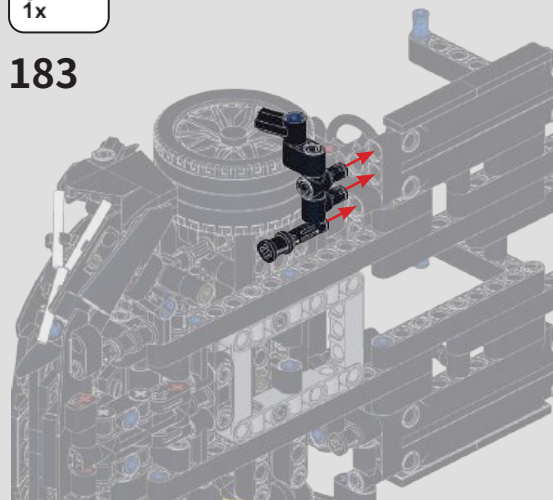

184

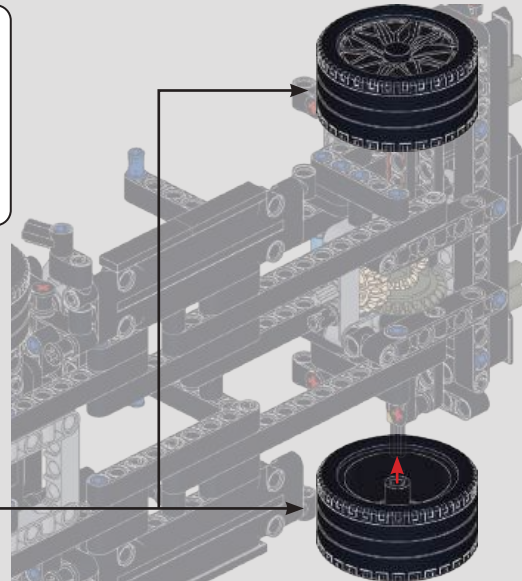
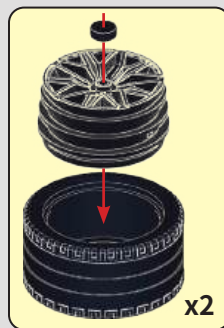

28



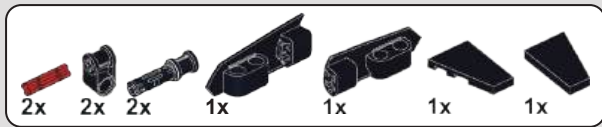

185

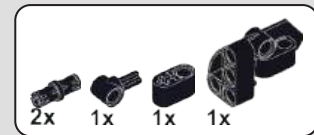
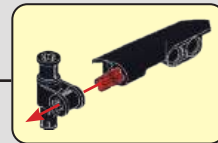
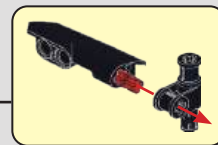
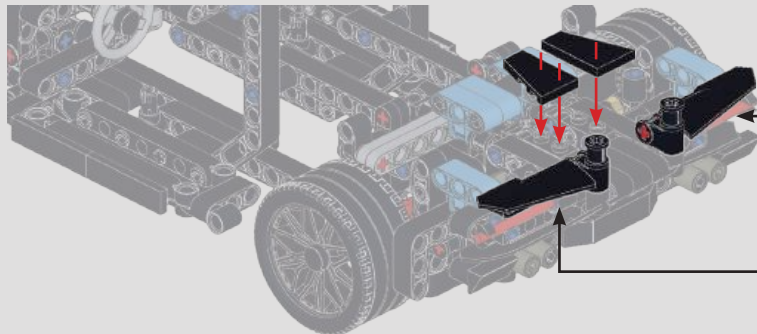

186

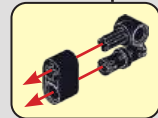
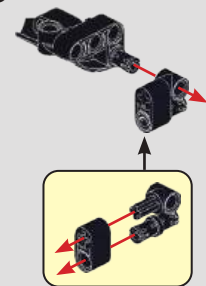

187

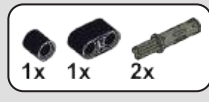
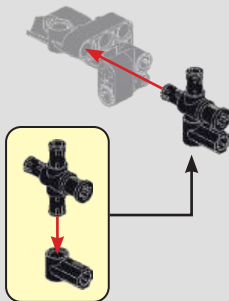

188

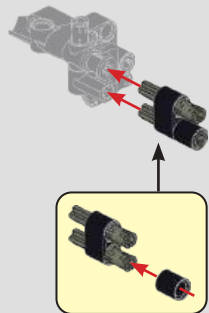

189

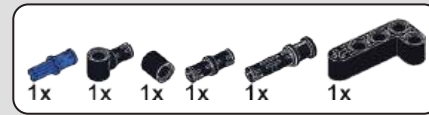
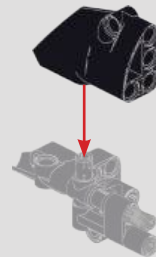

190

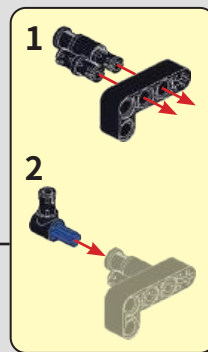
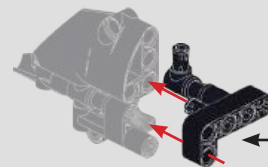

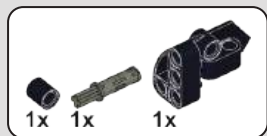

191

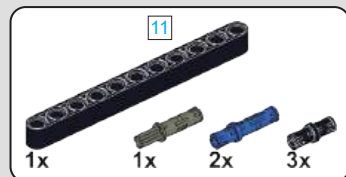
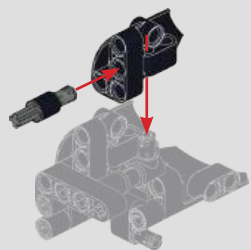

192

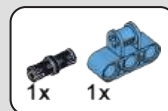
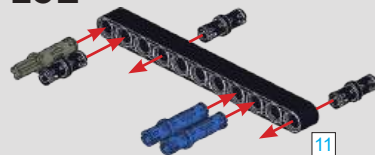

193

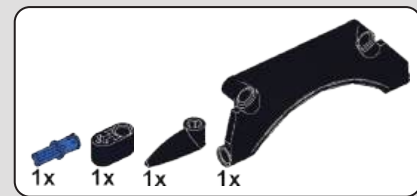
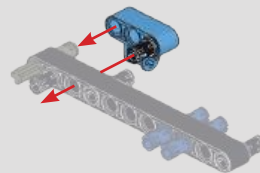

194

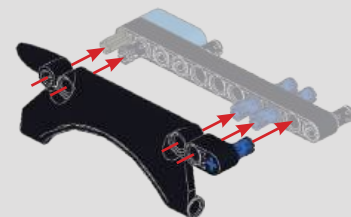

195

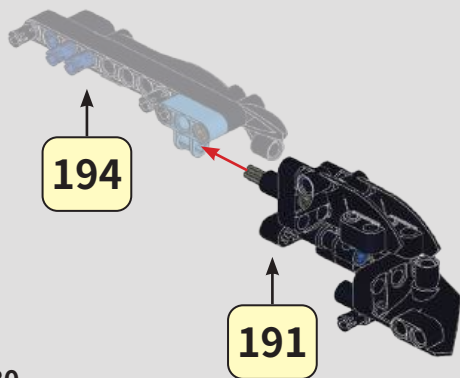

196

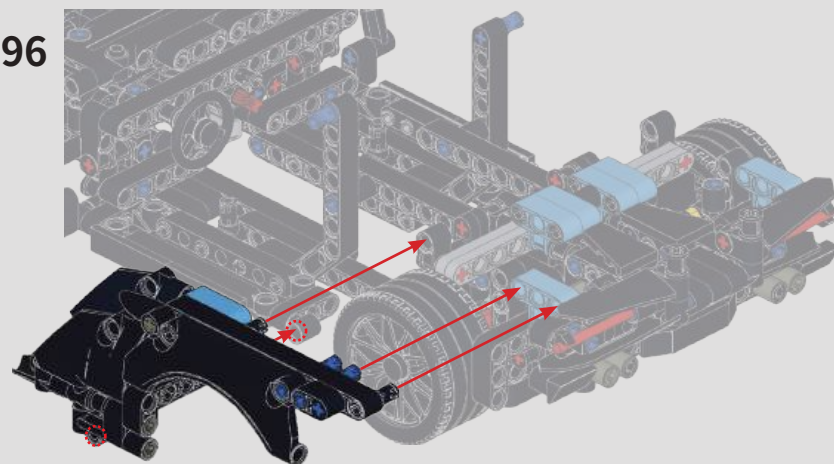



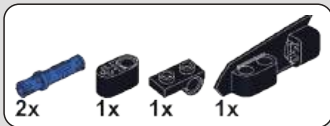

197

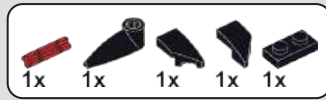
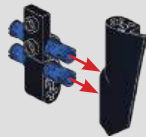

198

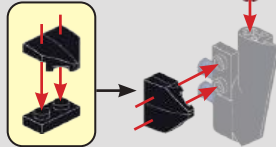

199

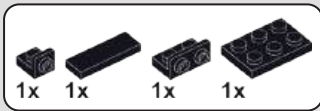
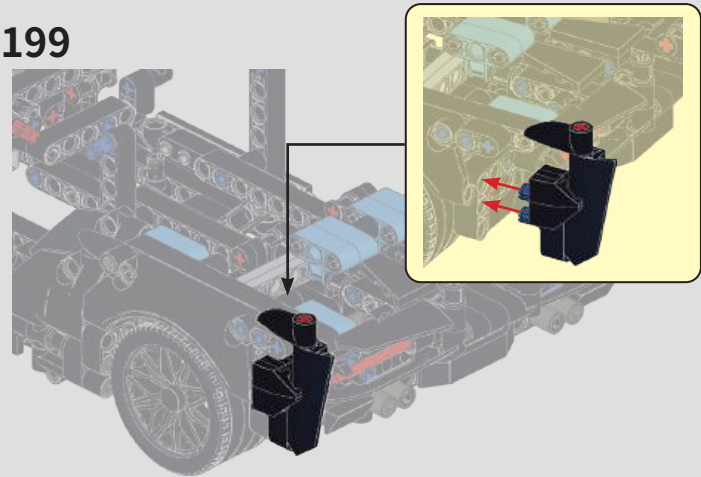

200

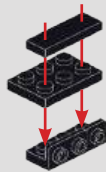

201

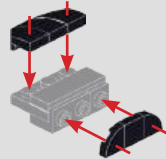

202

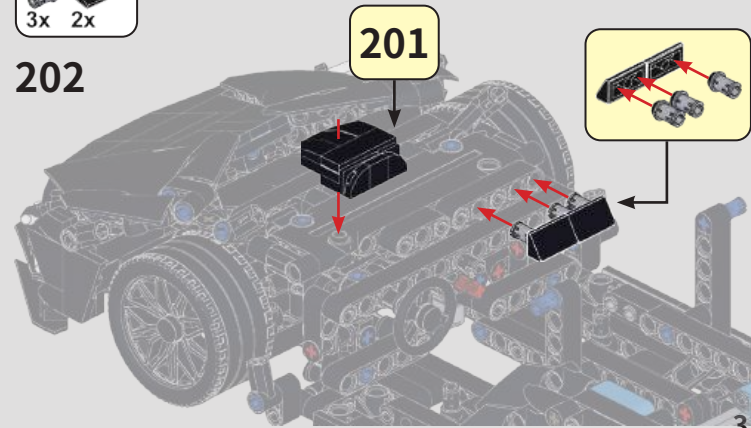

31

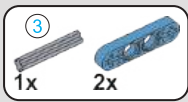

203

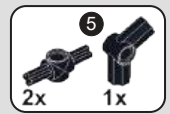
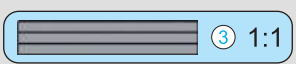
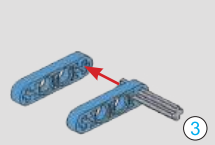

204

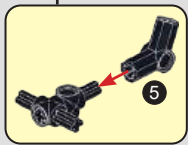
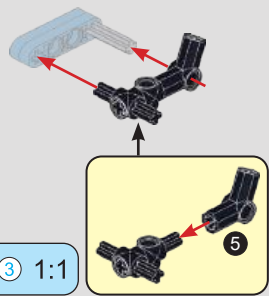

205

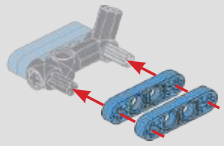

206

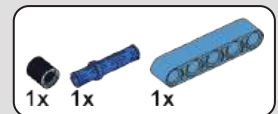
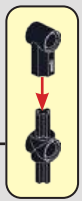
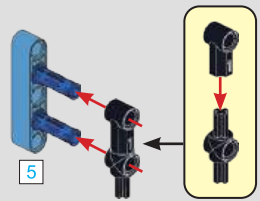

207

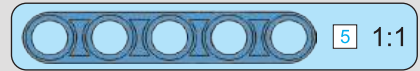
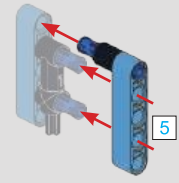

208

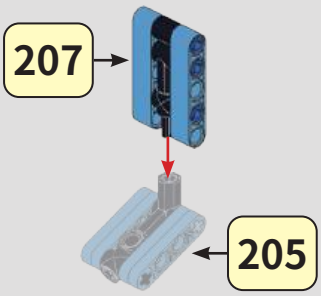

209

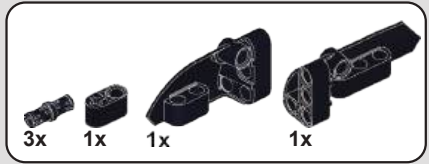
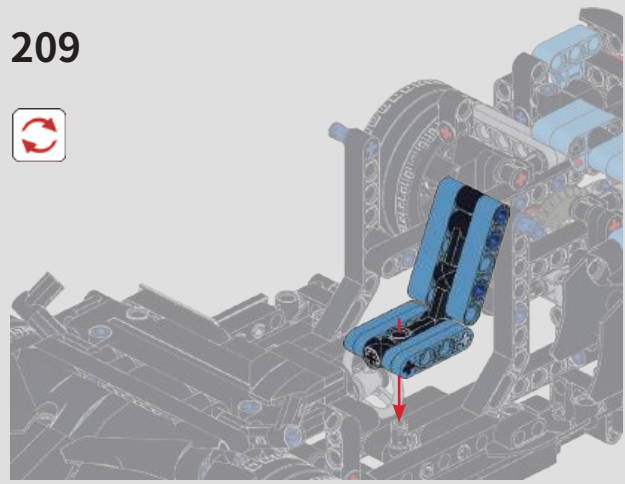

210

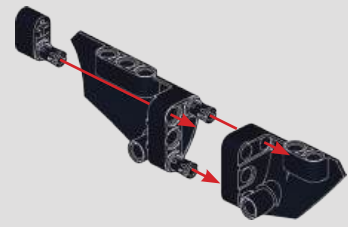

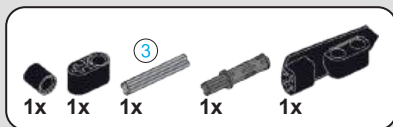

211

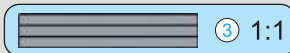
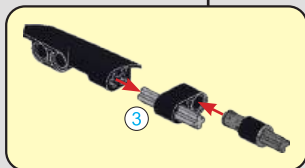
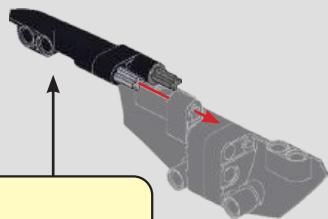

212

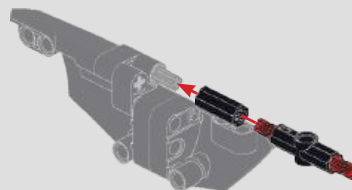

213

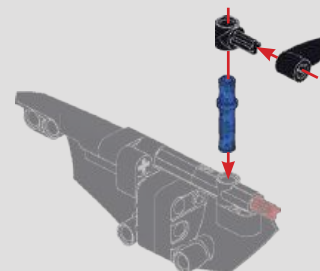

214

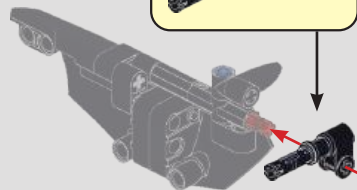
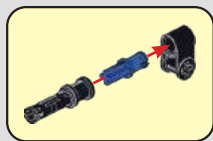

215

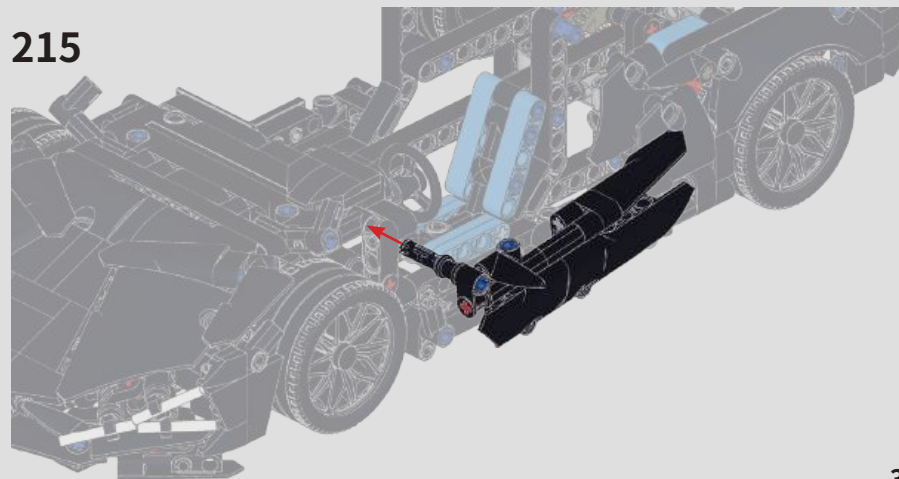

33



216

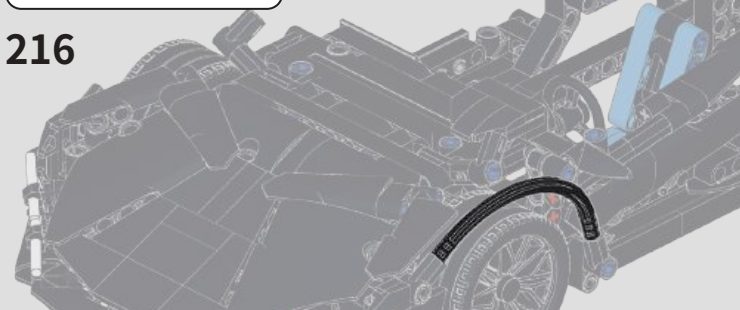

217

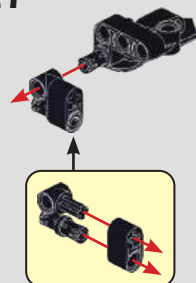

218

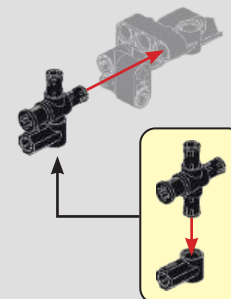

219

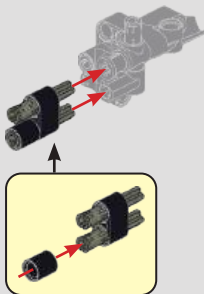

34

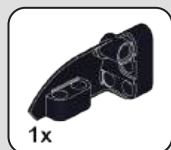

220

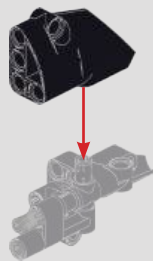

221

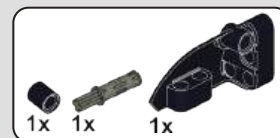
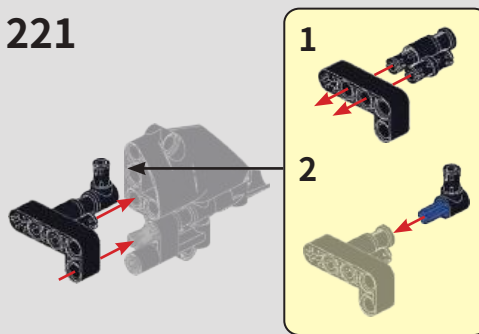

222

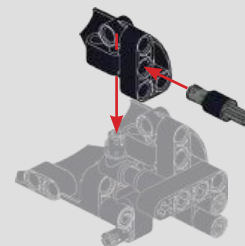

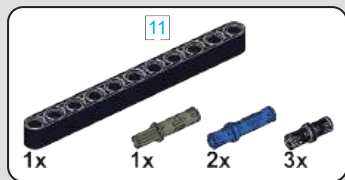

223

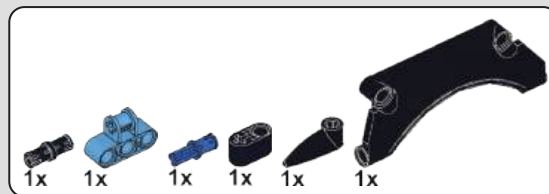
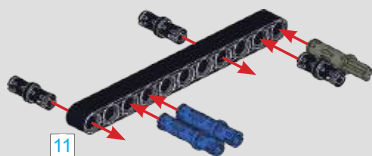

224

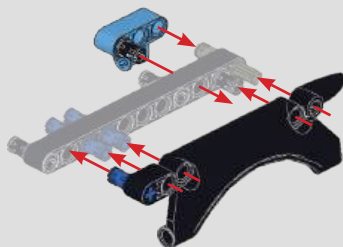

225

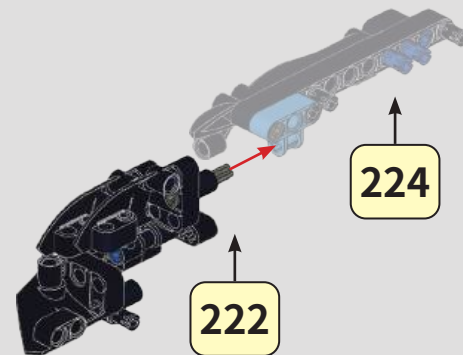

226

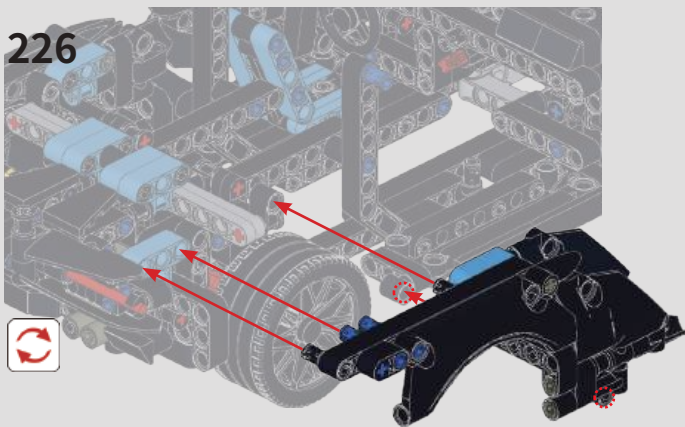

227

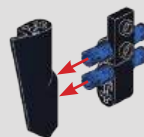

228

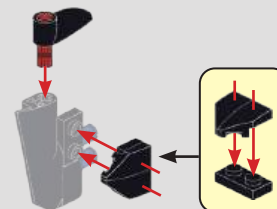

35

229

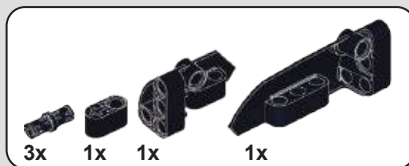
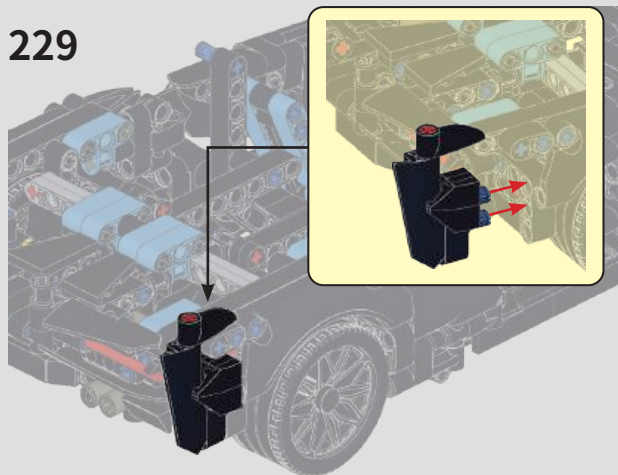

230

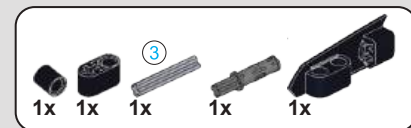
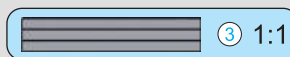
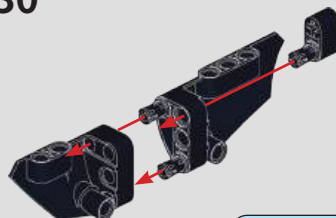

231

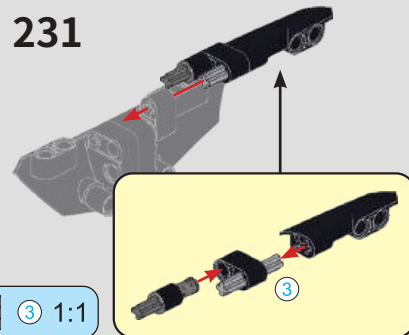

232

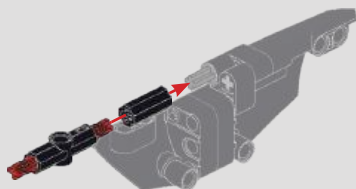

233

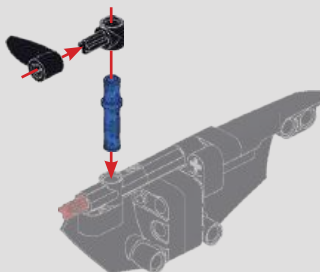

234

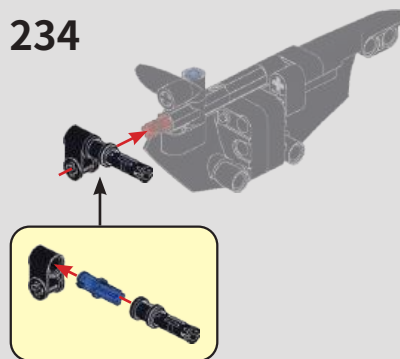

235

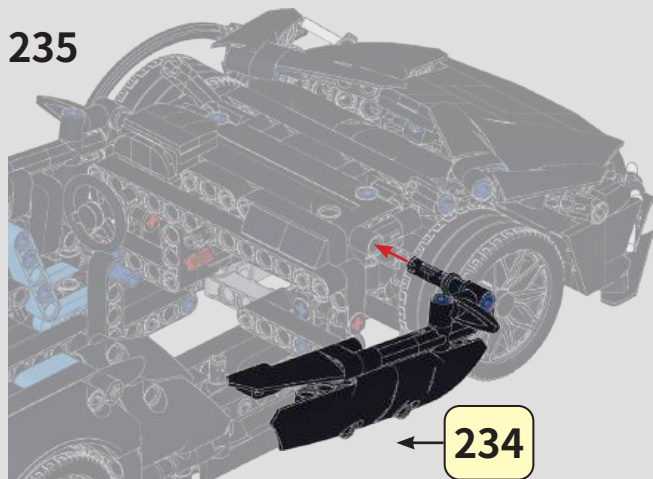

236

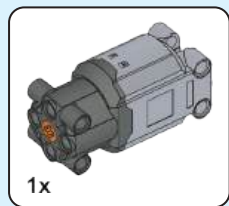
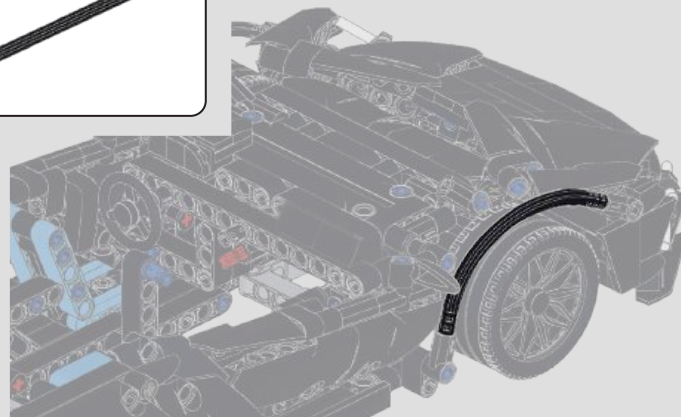

237

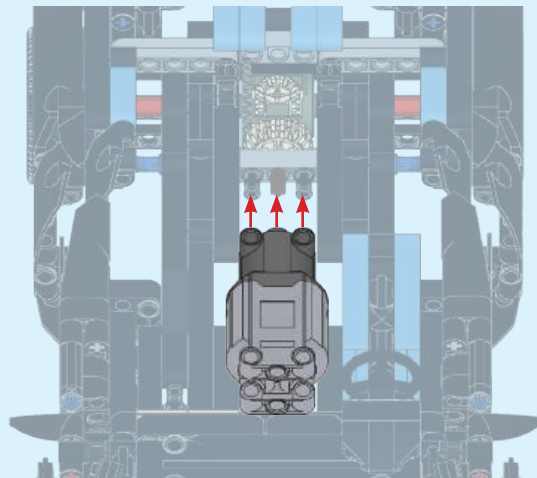

**Note: The blue page shows the installation steps of the power version /  
 Uwaga: niebieska strona pokazuje kroki instalacji wersji zdalnej /  
 Poznámka: Modrá stránka s kroki vzdalenejšej inštalácie /  
 Poznámka: Modrá stránka s kroky vzdálenější instalace**

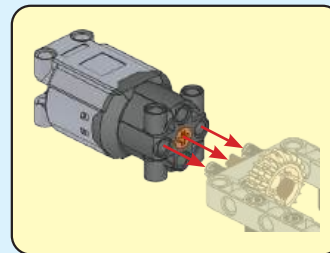

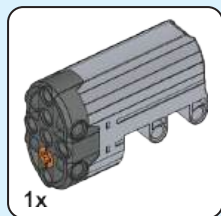

238

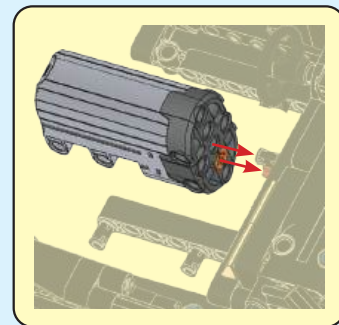
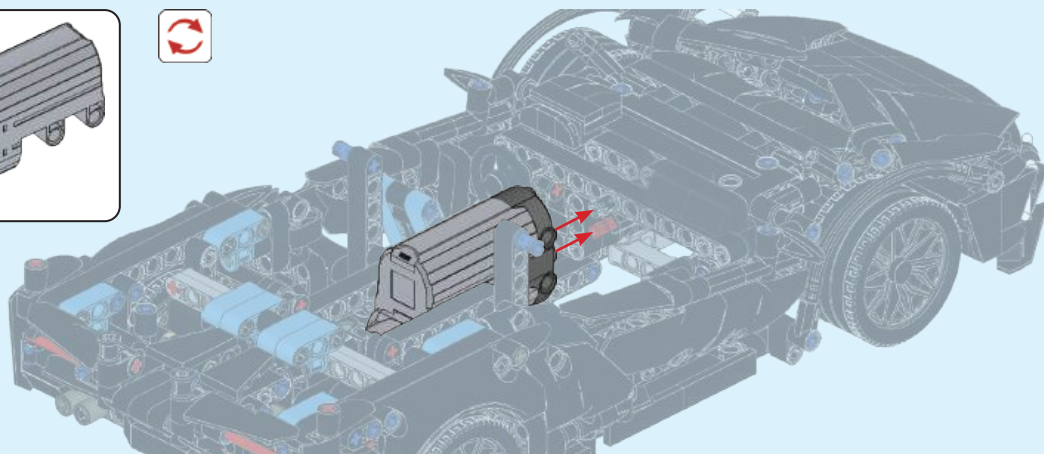

239

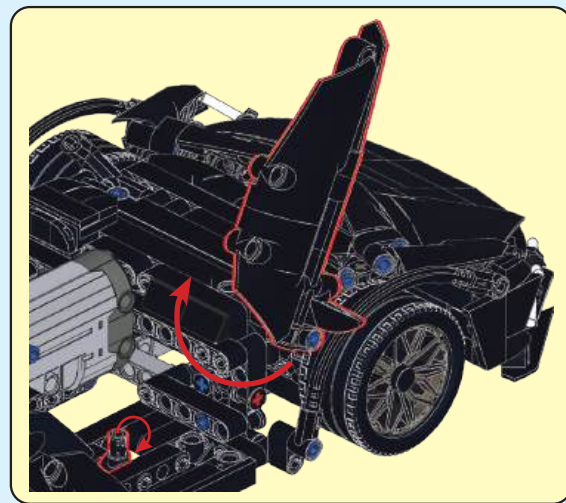
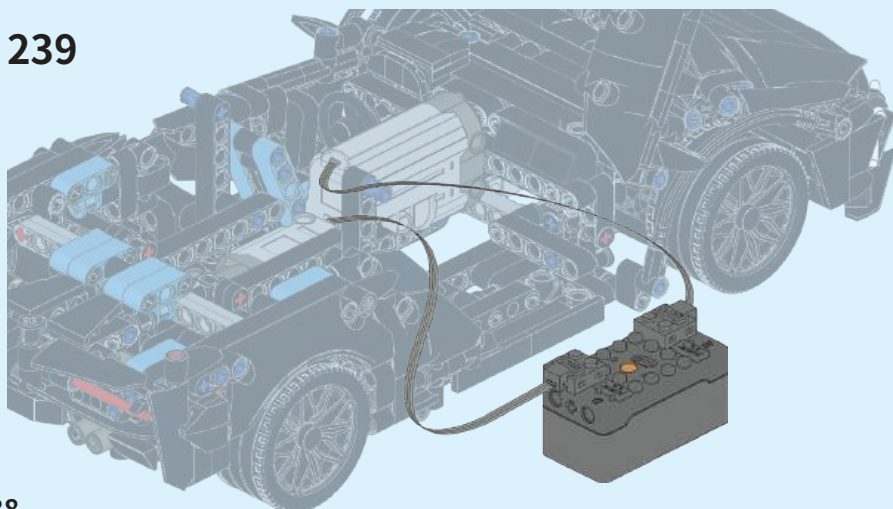

38







240

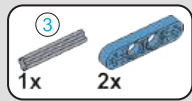
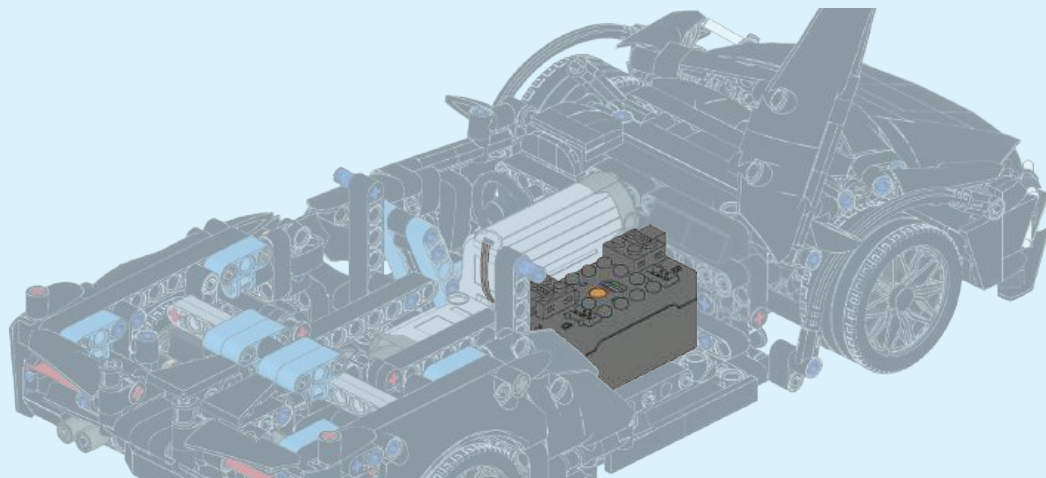

241

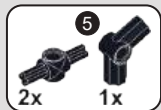
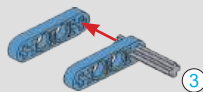

242

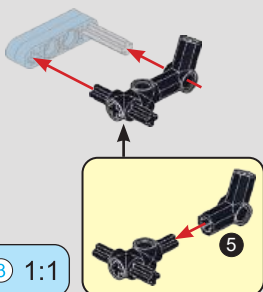

243

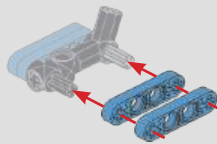

244

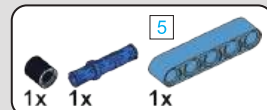
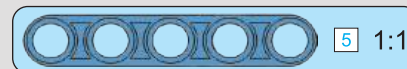
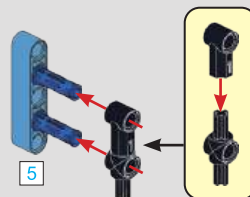

245

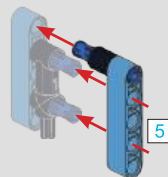



246

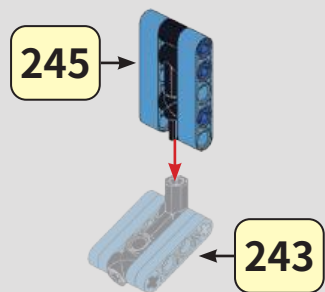

247

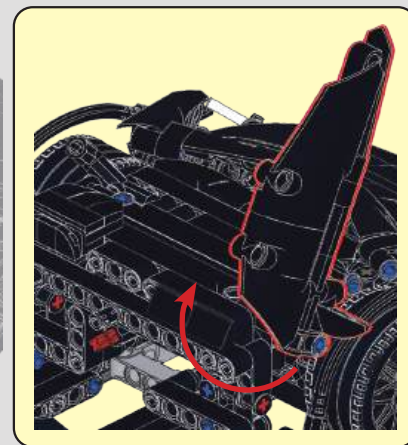
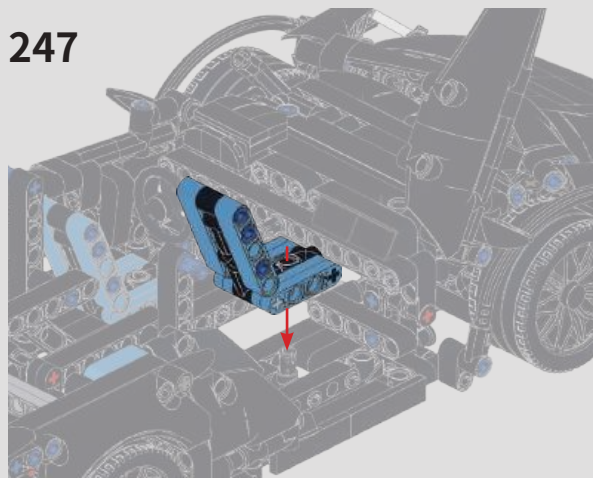

248

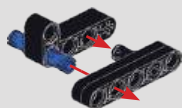

40

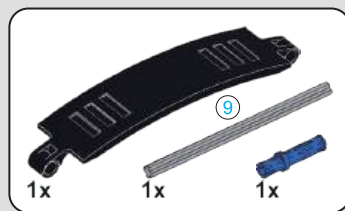

249

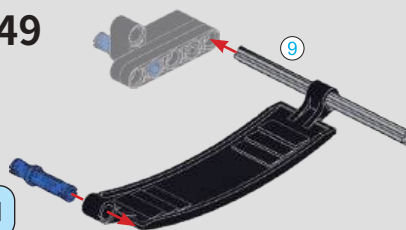

250

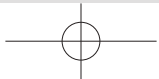
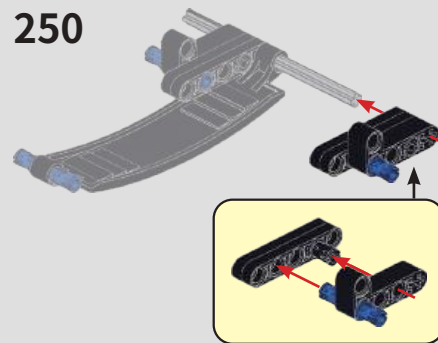



251

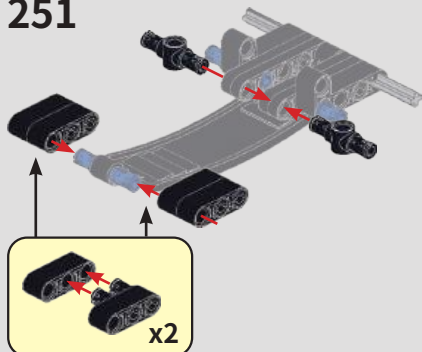

252

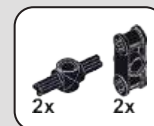
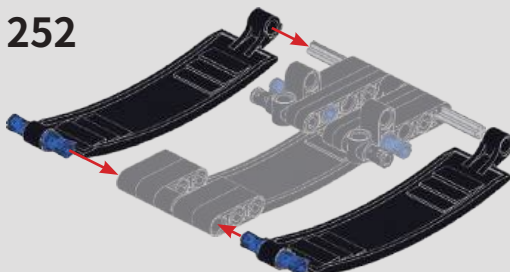

253

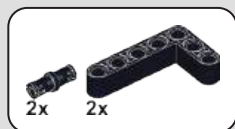
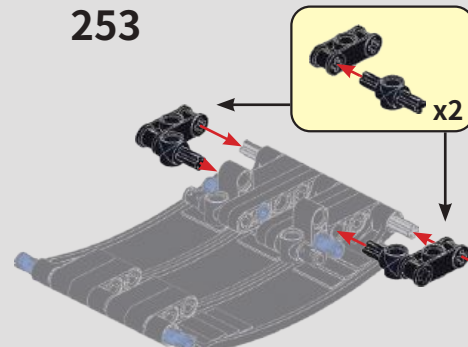

254

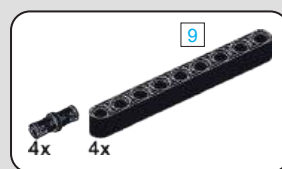
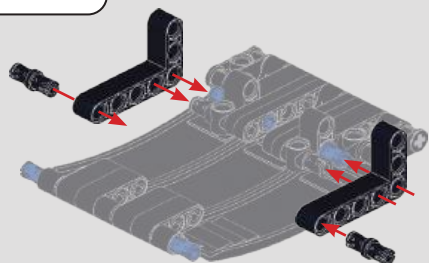

255

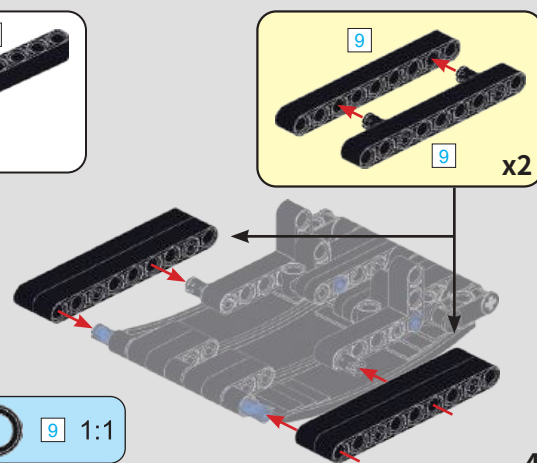

9 1:1



256

255

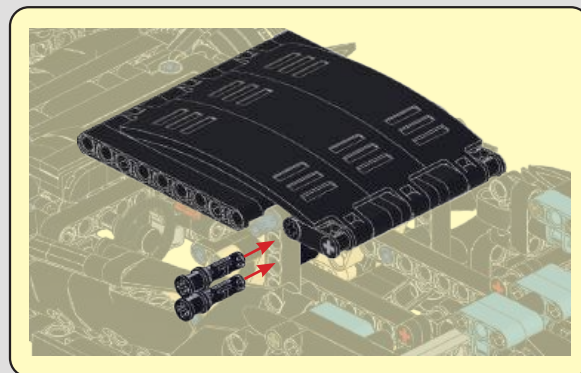
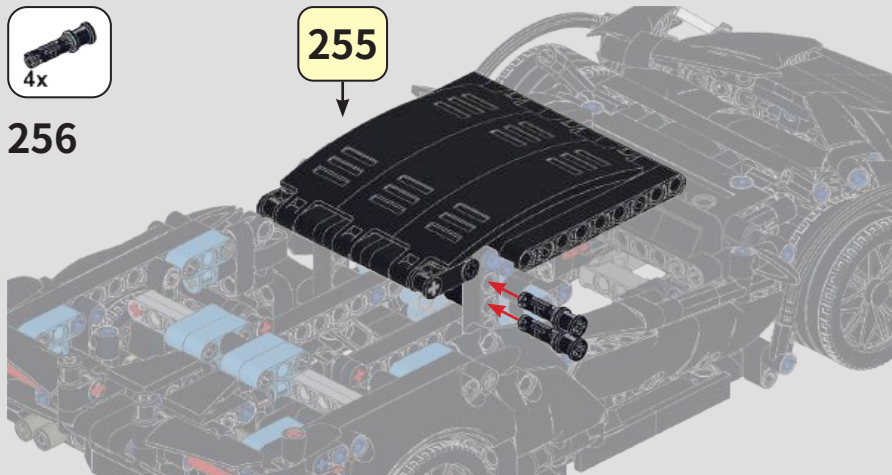

257

42

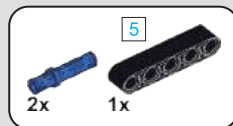

258



259

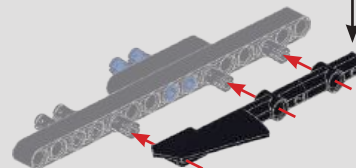
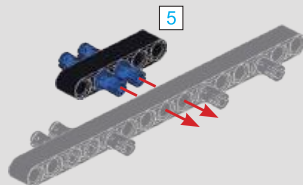
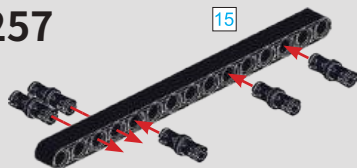
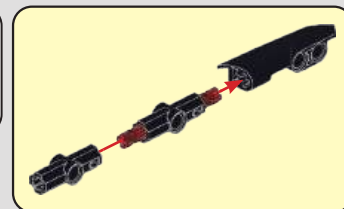



260

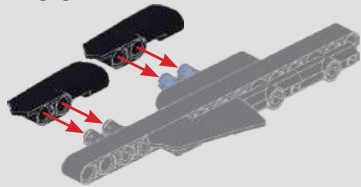

261

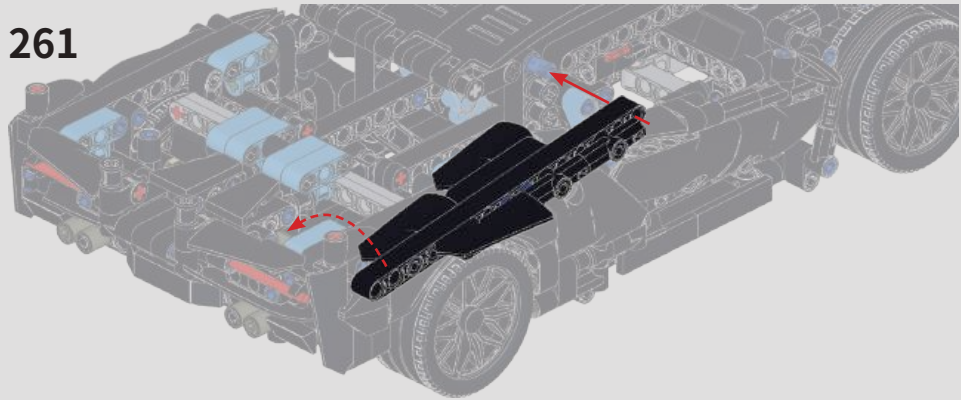

262

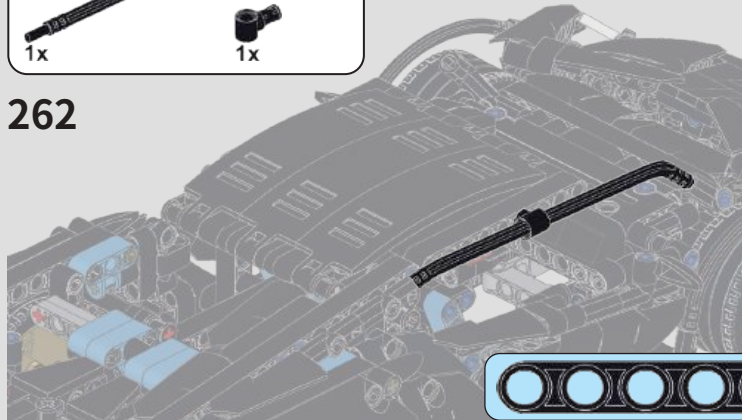

263



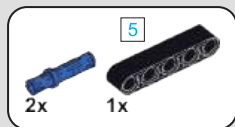

264

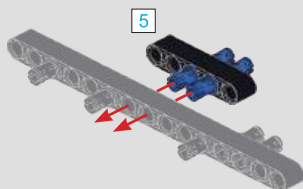

267



265

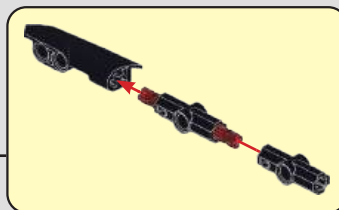
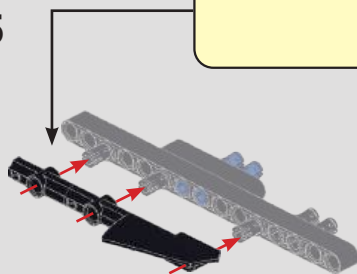

266

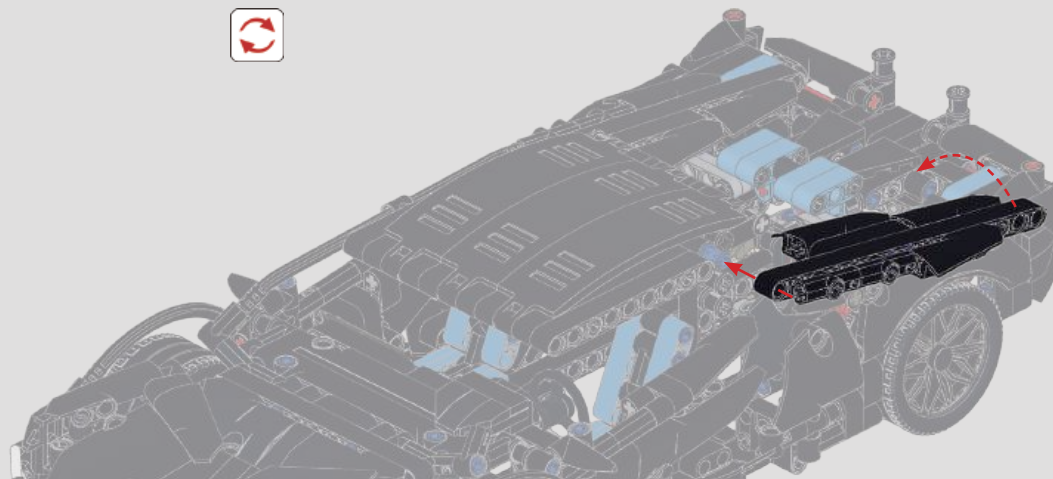
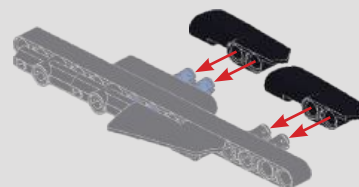



268

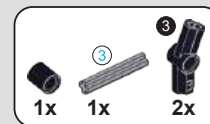
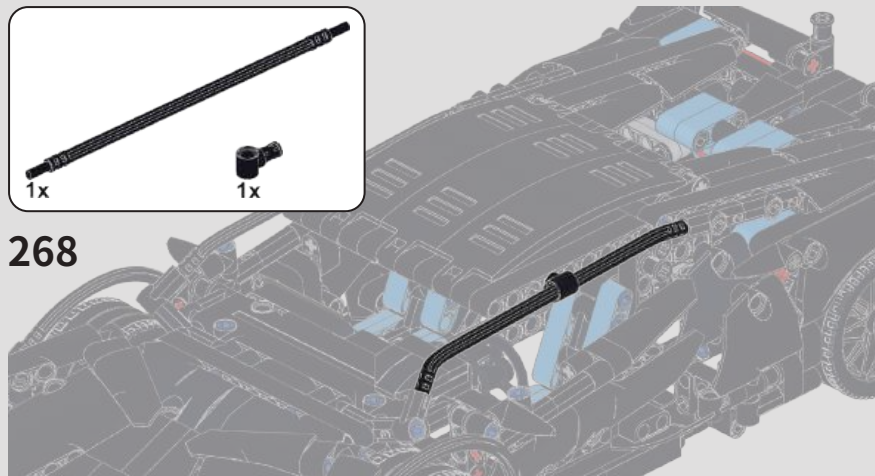

269

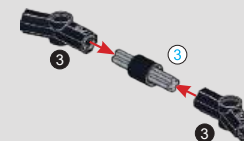

270

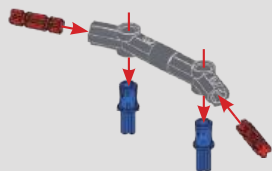

271

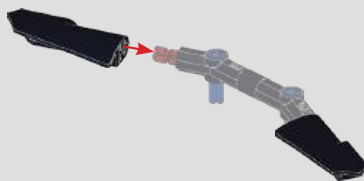

272

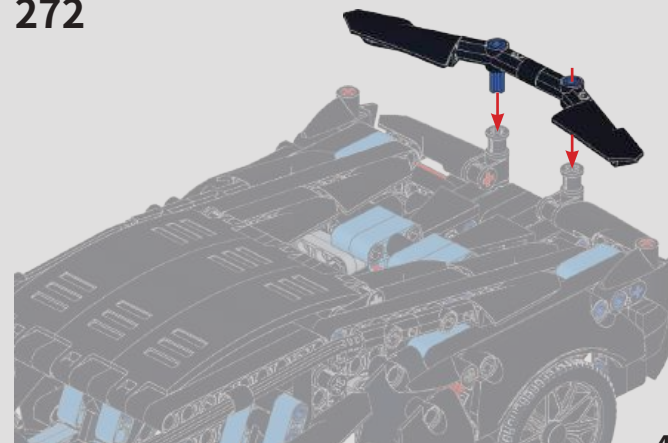

45



Note: This is a step-by-step description of converting a static version to a dynamic version/ Uwaga: jest to opis krok po kroku konwersji wersji statycznej na wersję dynamiczną / Poznámka: Toto je podrobný popis převodu statické verze na dynamickou verzi

The seat needs to be slightly steered before it can be pulled out / Fotelik należy lekko obrócić, zanim będzie można go wyciągnąć / Před vytažením je potřebné sedadlo mírně natočit' / Před vytažením je třeba sedadlo mírně natočit

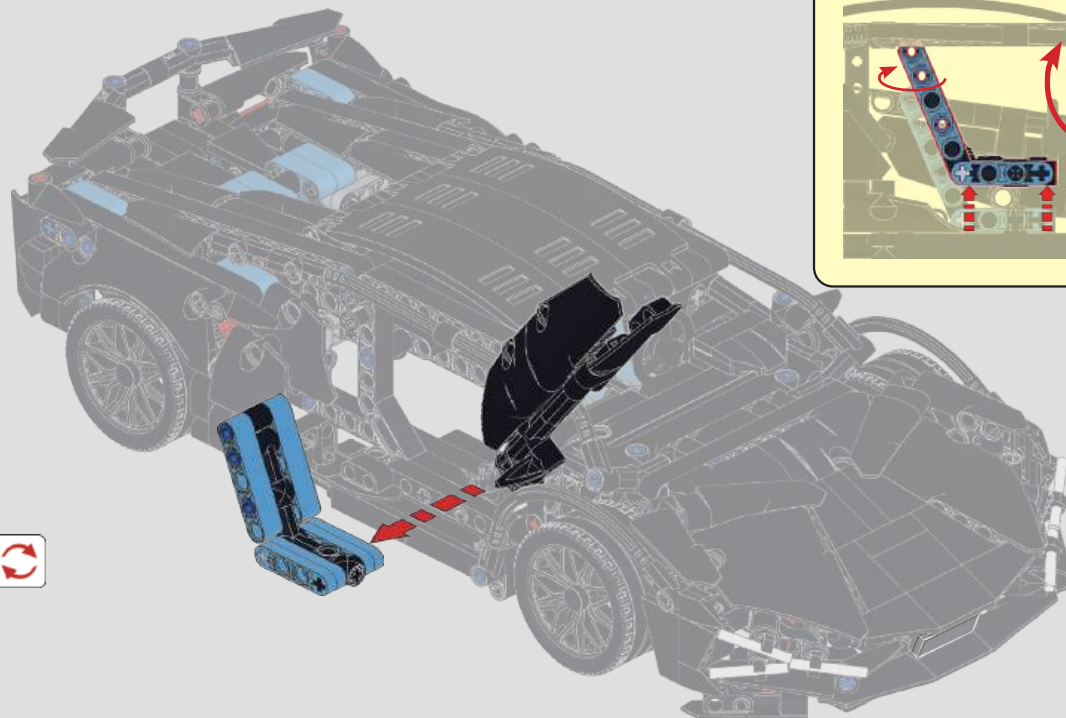
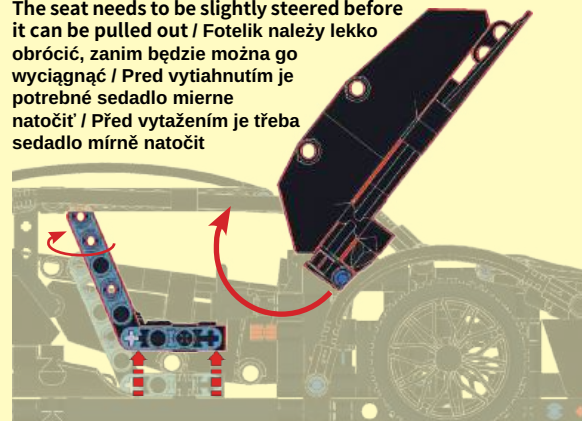



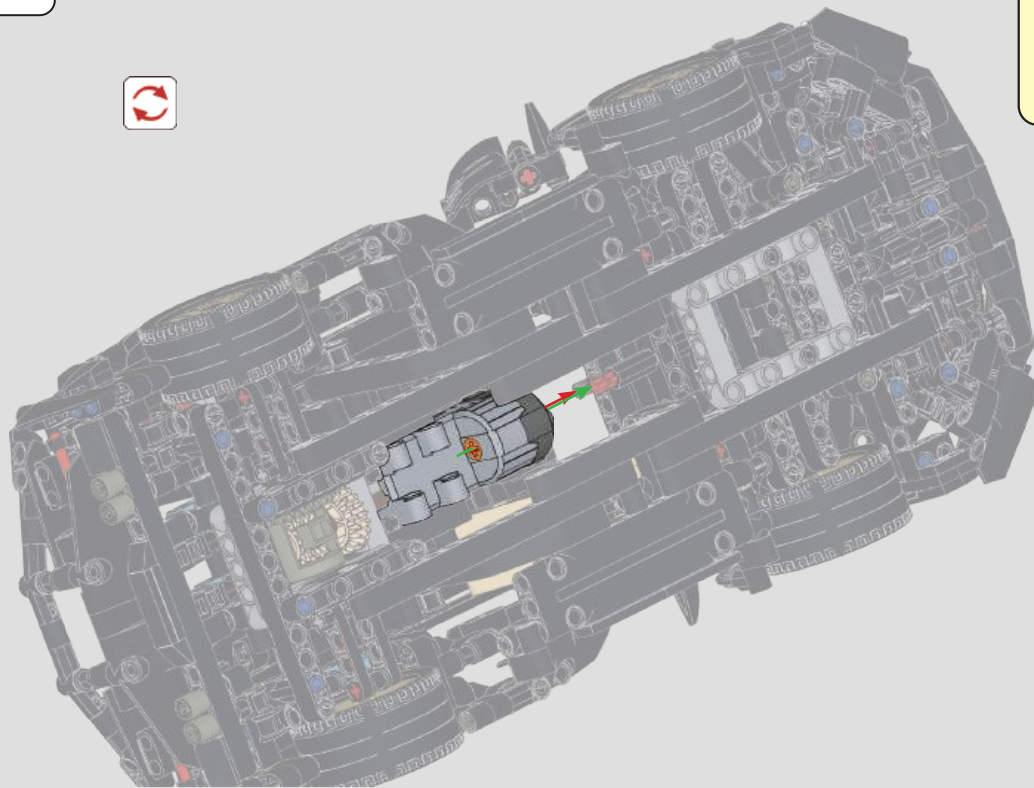
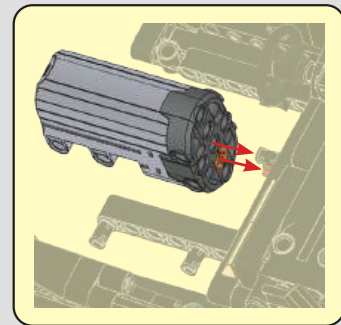
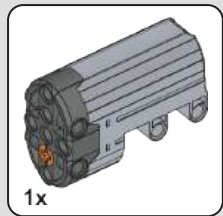

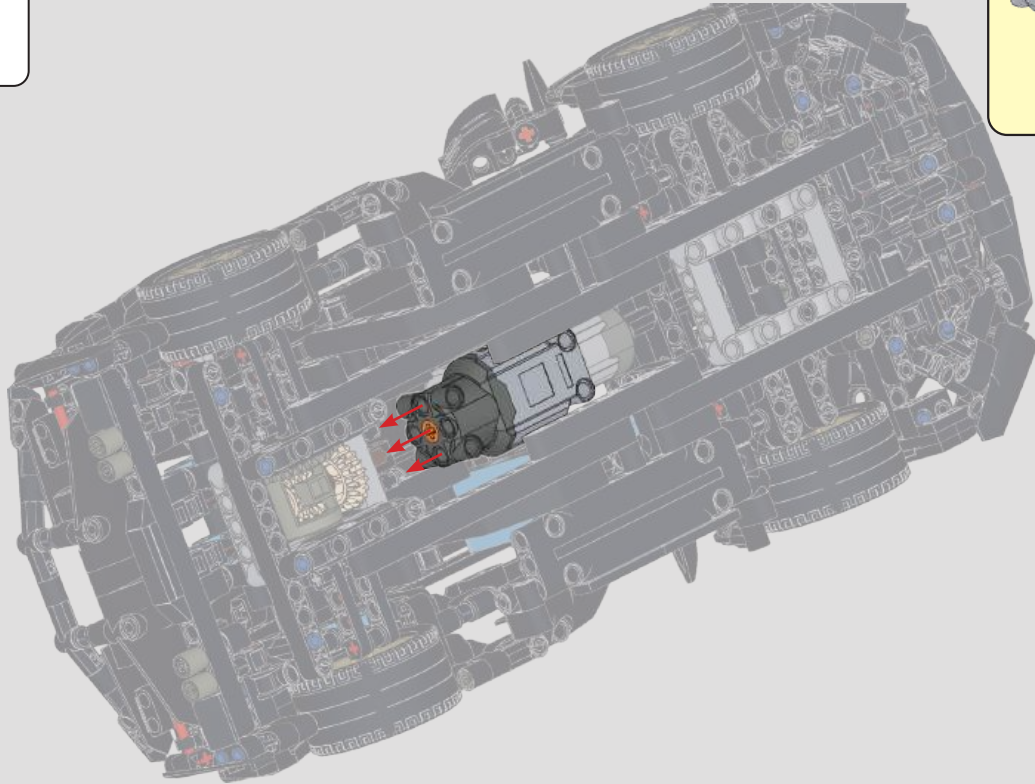
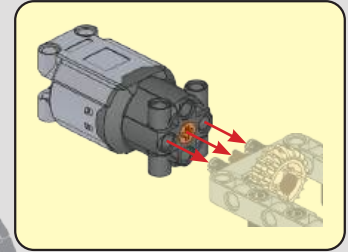
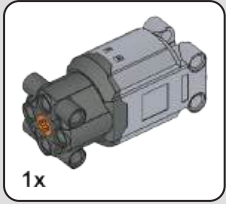

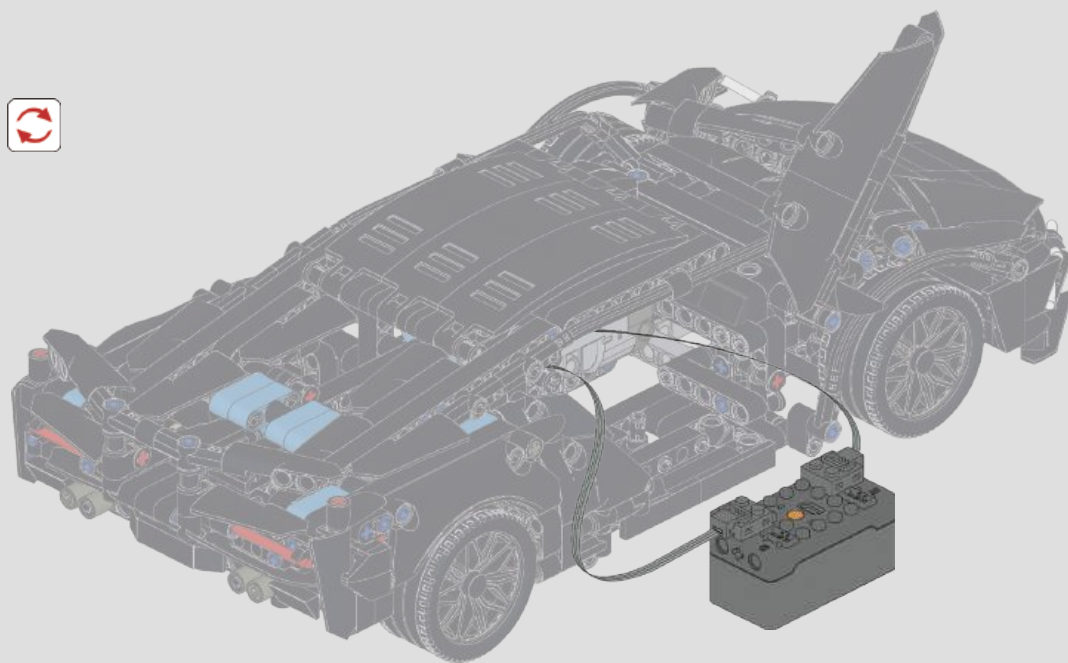



# LAM 1:14



20231027.06





52



53

# CYBERPUNK

STICKER GUIDE

Instrukcja do naklejek / Návod na nálepku / Návod na nálepku

