



搭建指南

BLOCK RACING



PLATED
METAL 1:14

E

Instruction Manual tips / Wskazówki dotyczące instrukcji obsługi / Tipy v návode na použitie / Tipy v návodu k použití

1

Open the numbered bags according to the instructions / Otwieraj ponumerowane woreczki zgodnie z instrukcją / Otvorte očíslované vrecká podľa pokynov / Otvérite očíslované sáčky podľa návodu

Bag G and unnumbered bags should be opened first / Woreczek G oraz woreczki nieponumerowane należy otworzyć na początku / Vrečko G a nečíslované vrecia by sa mali otvoriť ako prvé / Sáčok G a nečíslované sáčky by mali byť otvorené ako prvé

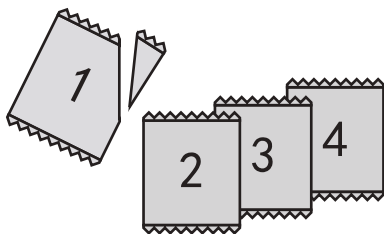
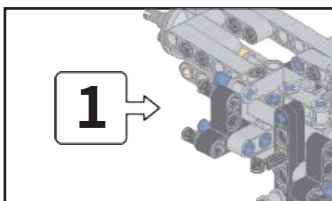

2

Use the 1:1 legend to quickly find parts of the right length / Użyj legendy 1:1, aby szybko znaleźć części o odpowiedniej długości / Použite legendu 1:1 na rýchle nájdenie častí správnej dĺžky / Použite legendu 1:1 k rýchlemu nalezání částí správné délky

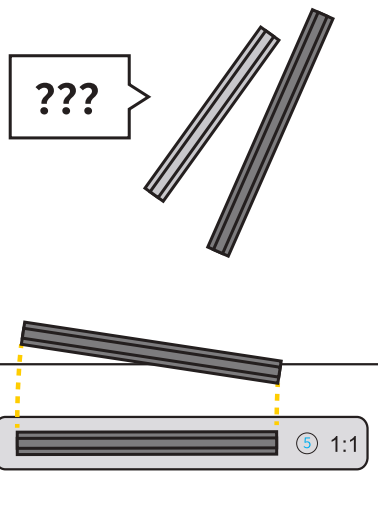

3

The meaning of the icons in the instruction manual / Znaczenie ikon w instrukcji obsługi / Význam ikon v návode na použitie / Význam ikon v návodu k použití



Rotate the structures
Obróć konstrukcje
Otočte štruktúry
Otočte struktúry



The number indicates the corresponding sticker number
Liczba wskazuje odpowiedni numer naklejki
Číslo označuje príslušné číslo nálepky
Číslo označuje odpovídající číslo nálepky

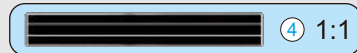
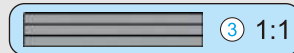
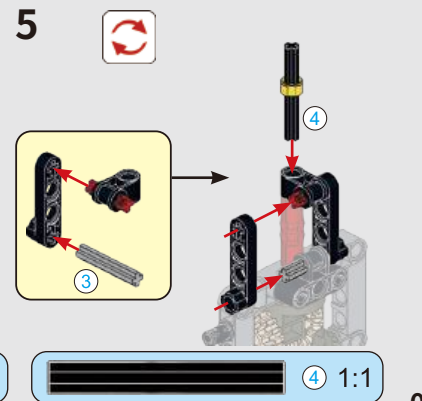
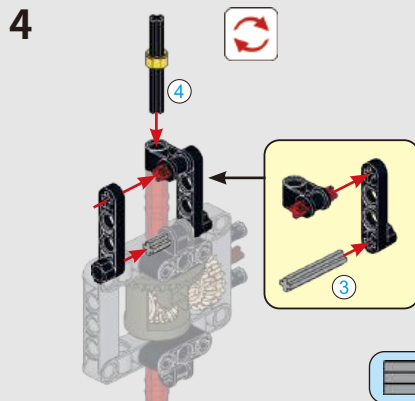
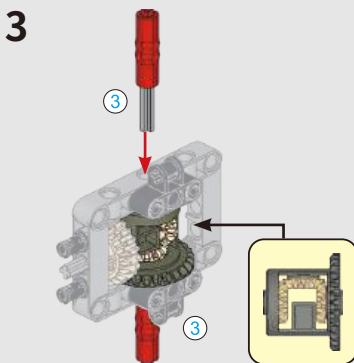
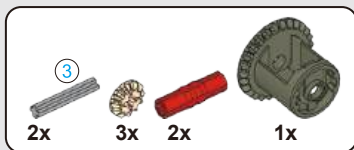
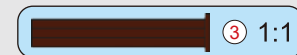
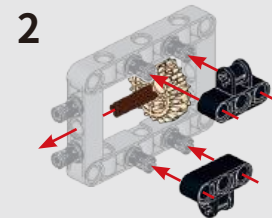
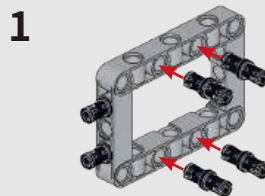
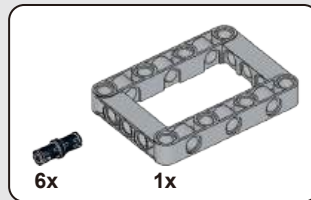
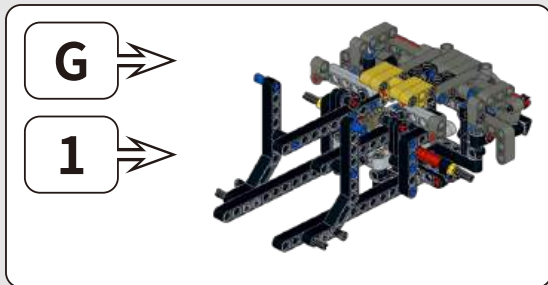

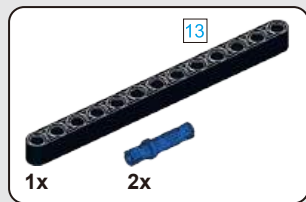

6

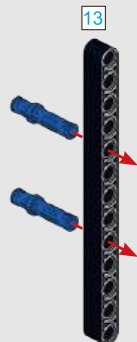

7

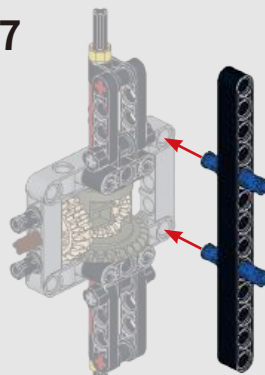

8

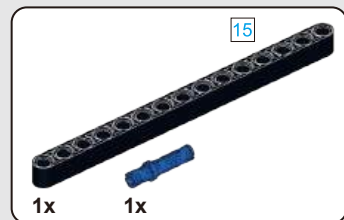
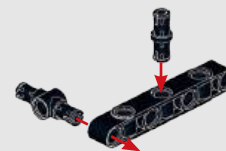

9

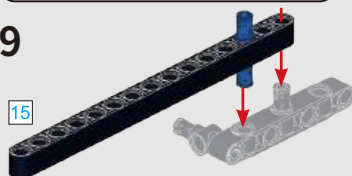

10

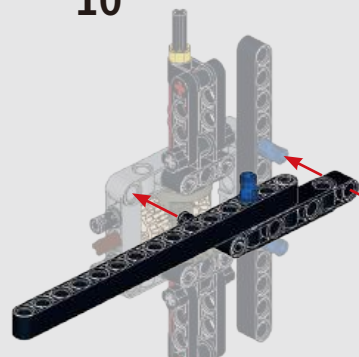

11

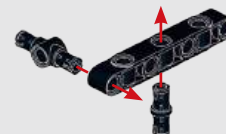

02



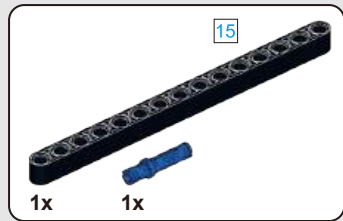

12

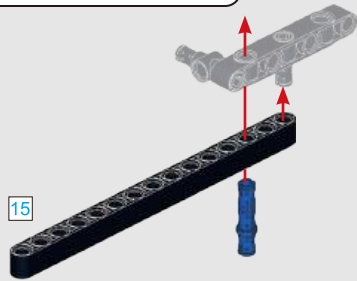

13

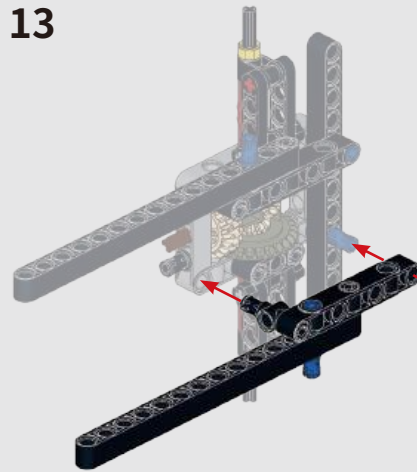

14



15

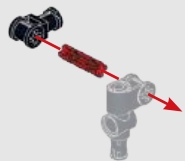

16

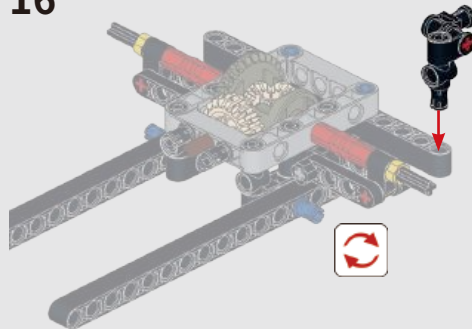

17



18

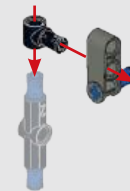

03

19

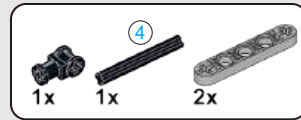
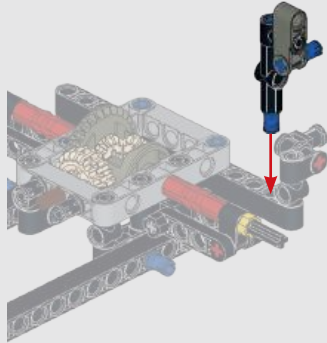

20

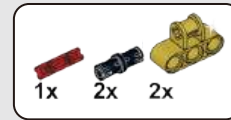
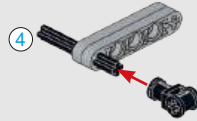

21

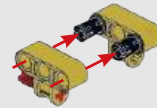

22

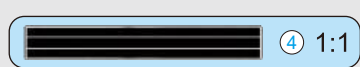
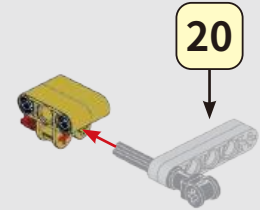

23

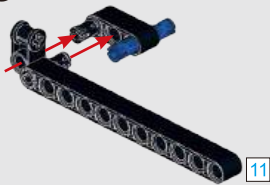

24

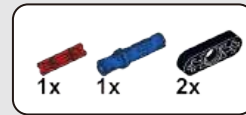
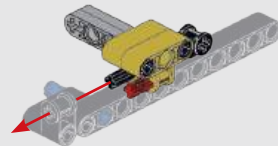

25

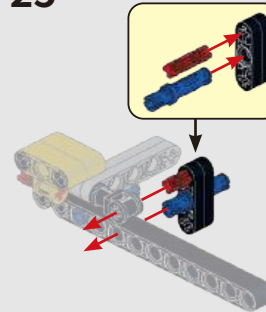

26

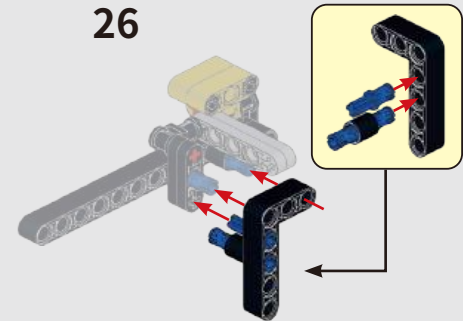

04



27

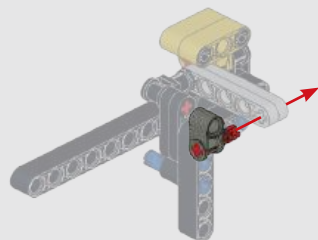

28

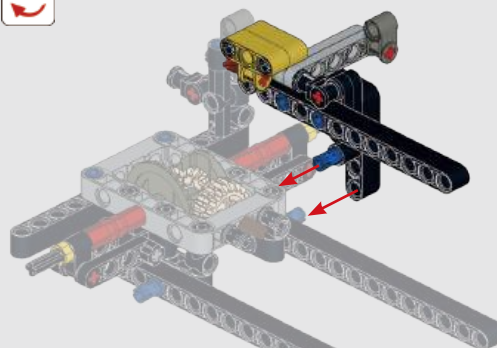

29



30

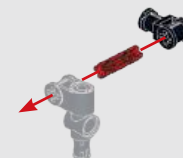

31

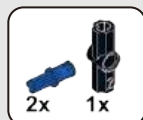
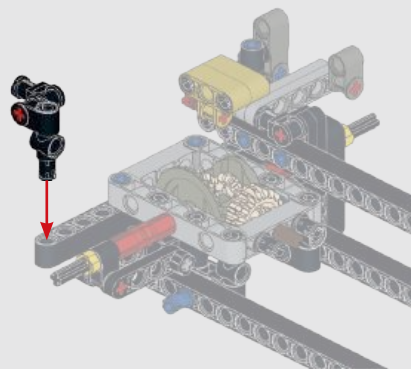

32



33

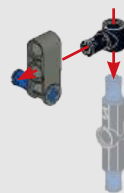

34

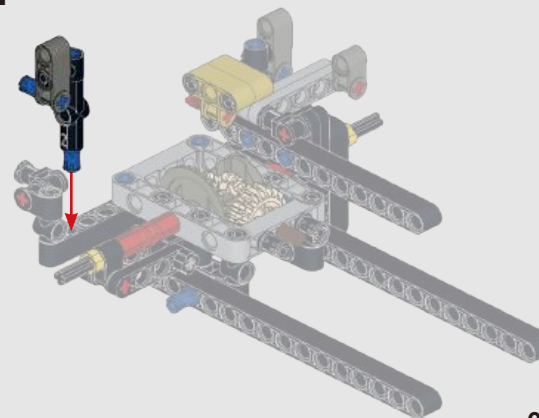

05



35

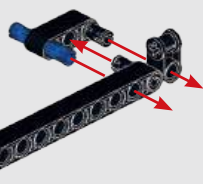

36

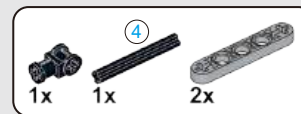
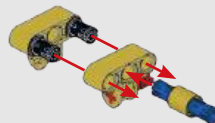

37

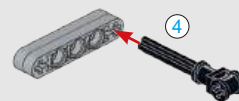

38

36

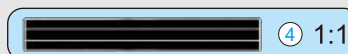
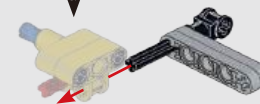

39



40

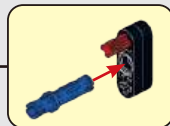
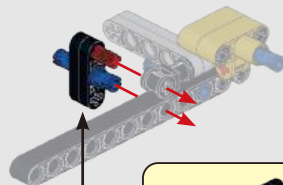
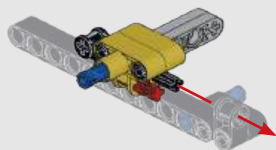

41

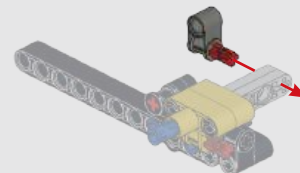

42

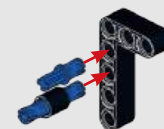

06





43

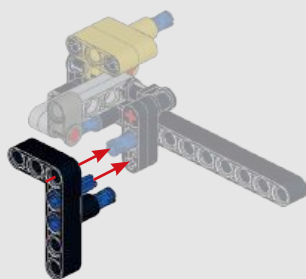

44

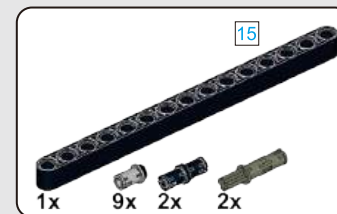
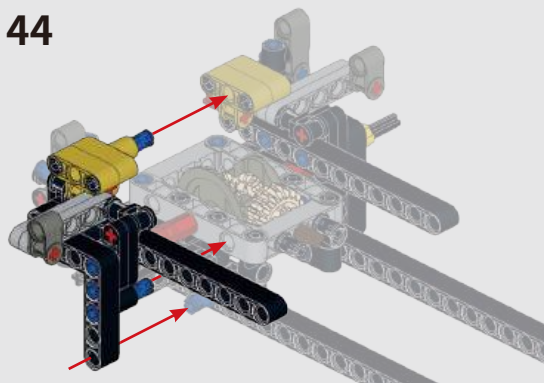

45



46

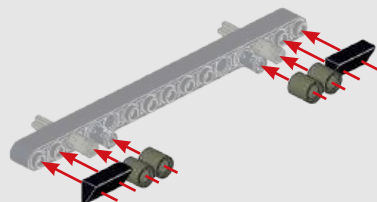

47

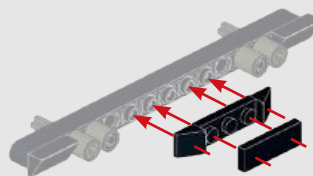

48

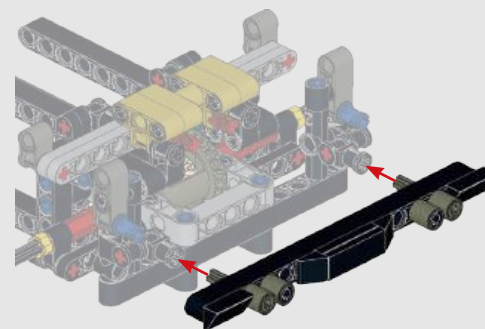

07

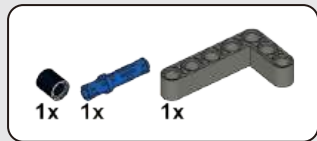

49

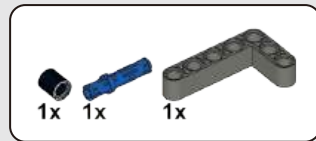
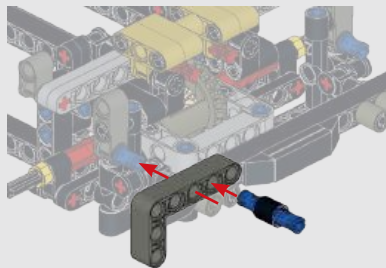

50

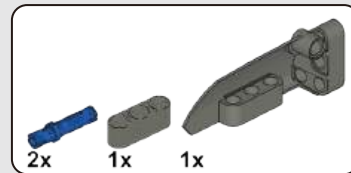
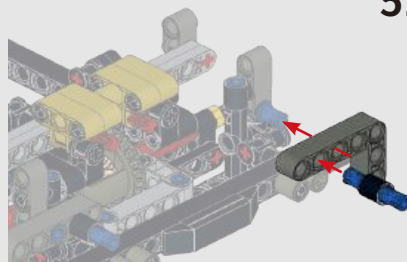

51

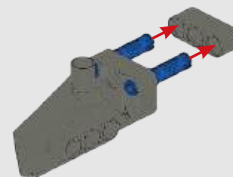

52

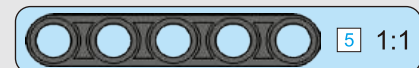
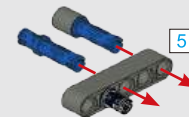

53

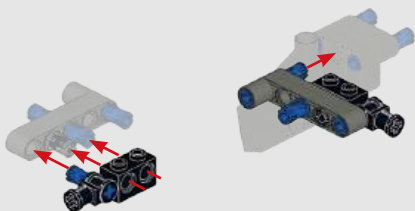

54



55

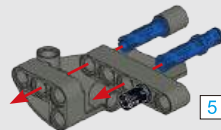

56

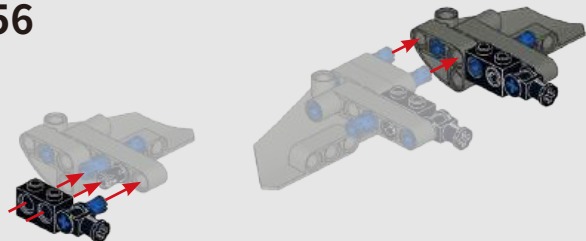

57

08



58

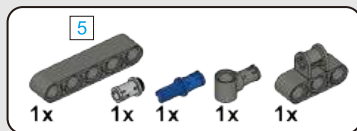
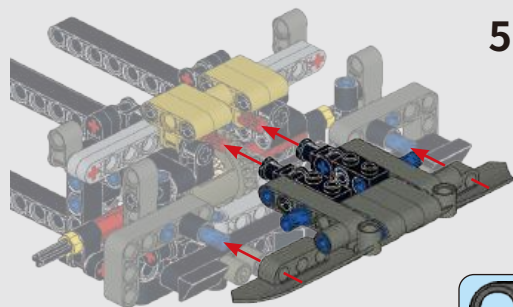

59

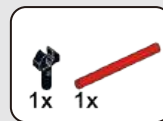
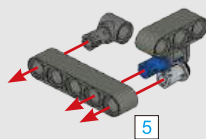

60

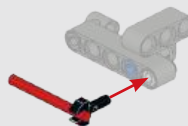

61

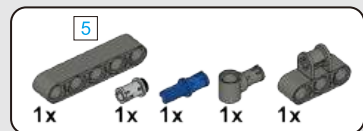
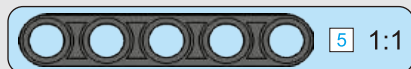
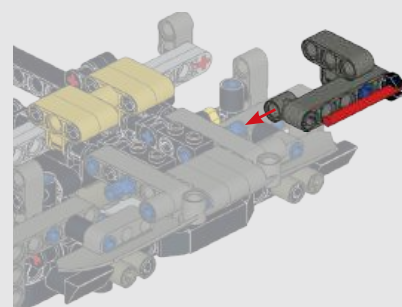

62

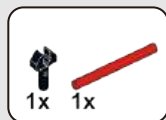
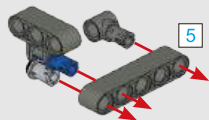

63



64

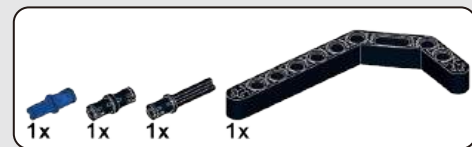
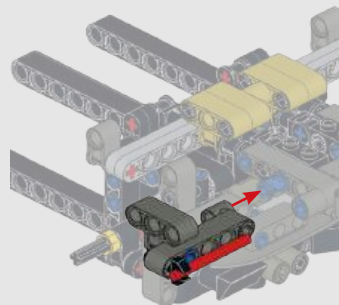

65





66

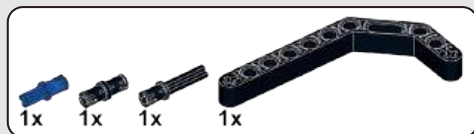
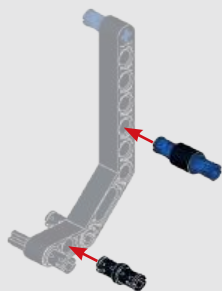

67



68

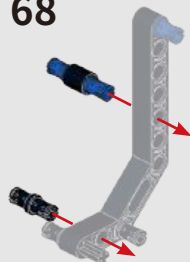

69

66

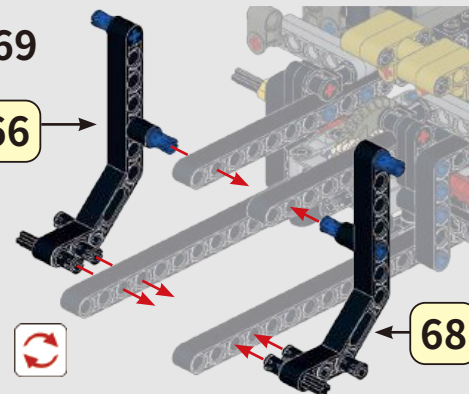

68

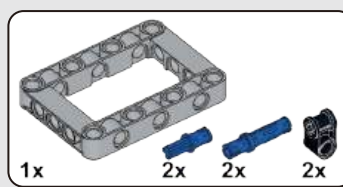
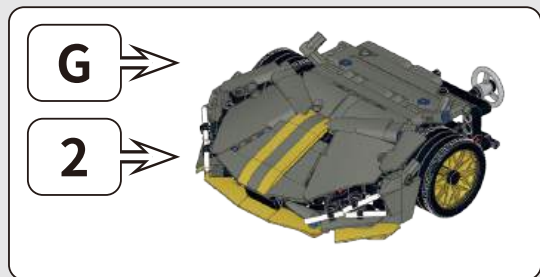

70

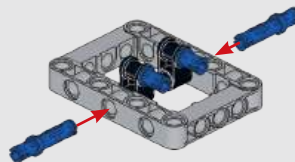

71

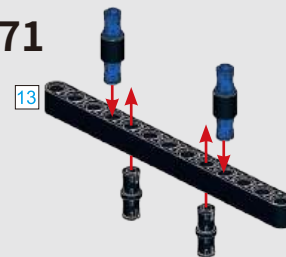

10





73



72

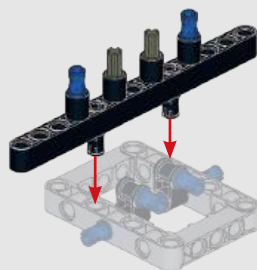
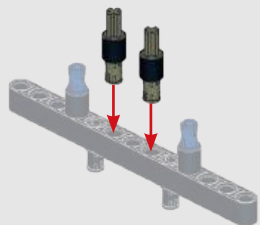

74

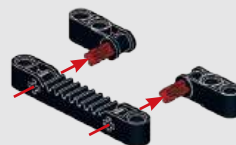

75

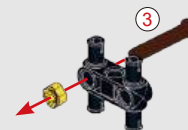

76

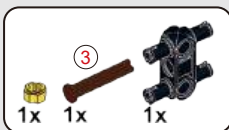
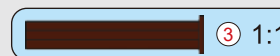

79

80

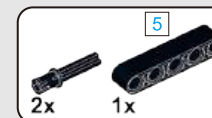

77

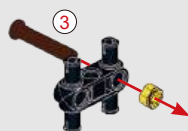

78

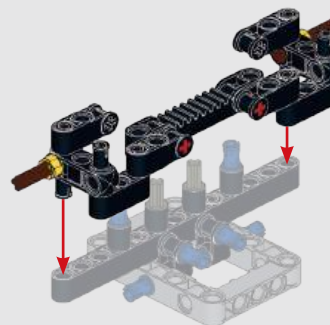
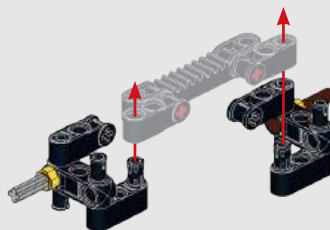

81



11



82

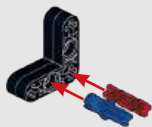

83

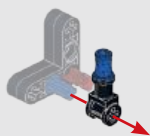

84

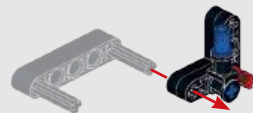

85

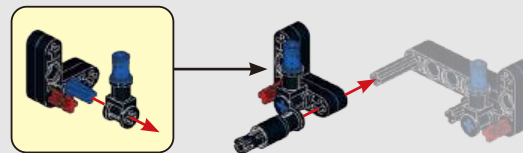

86

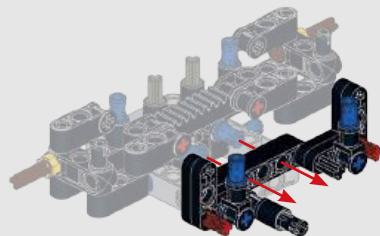

87

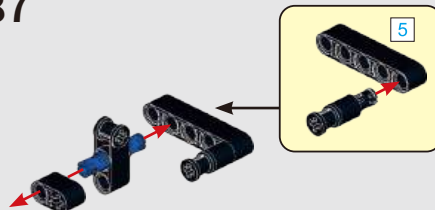

88

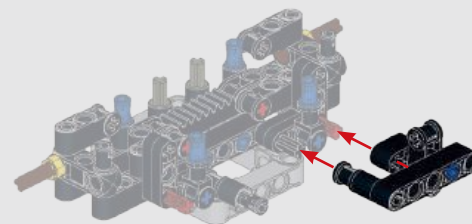

12

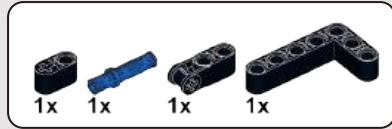

89

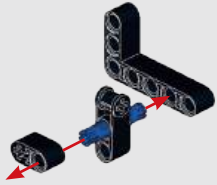

90

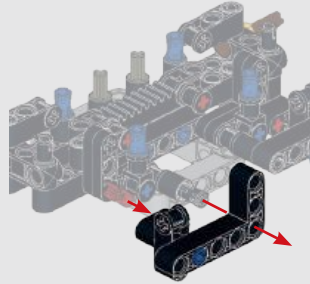

91

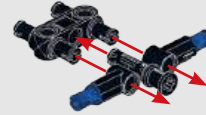

92

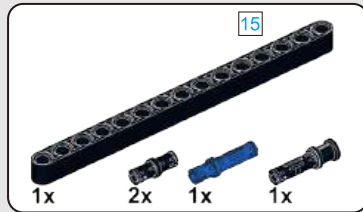
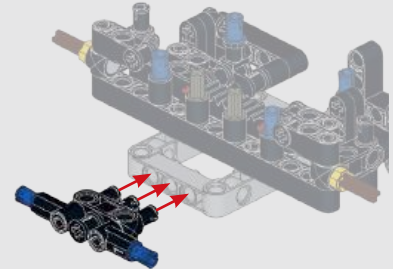

93

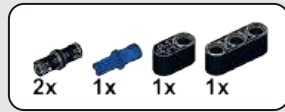
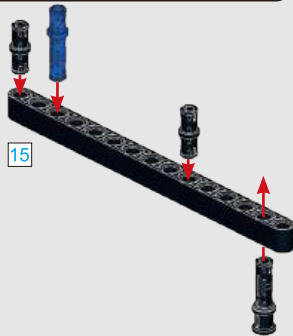

94

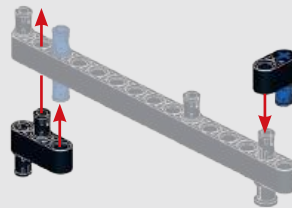

95

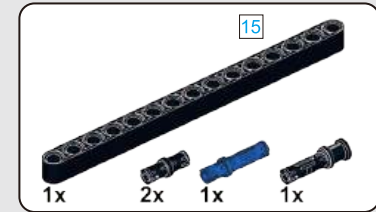
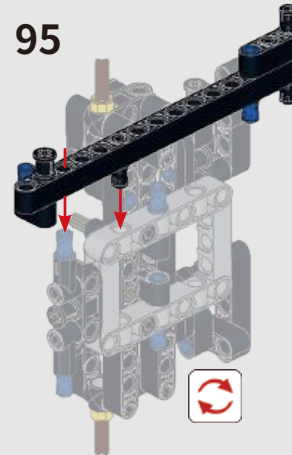

96

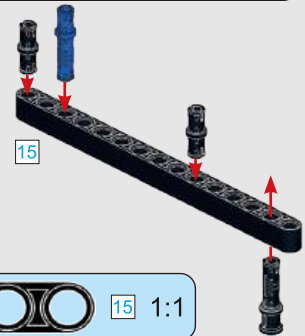

13

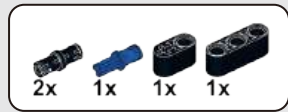

97

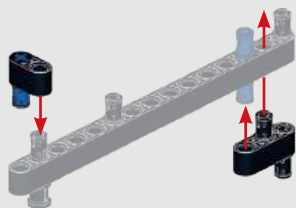

98

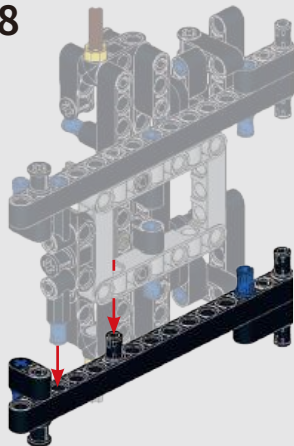

99

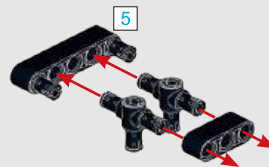

100

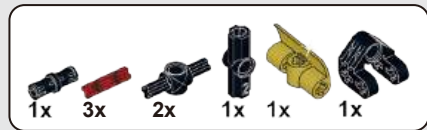
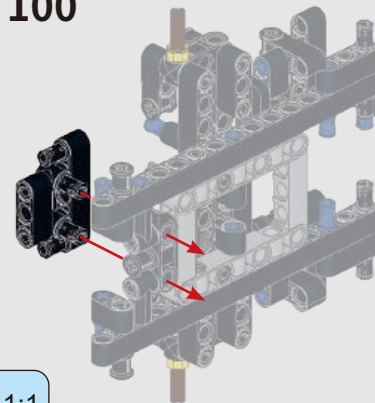

101

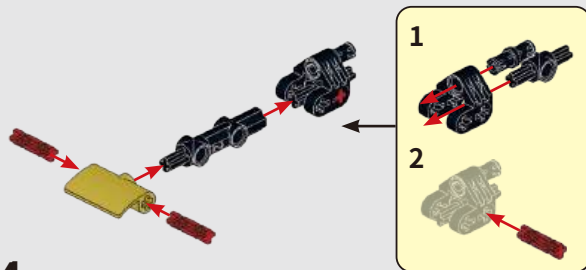

14

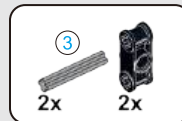

102

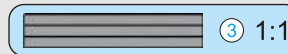
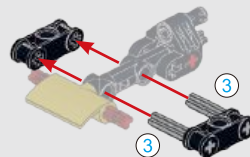

103

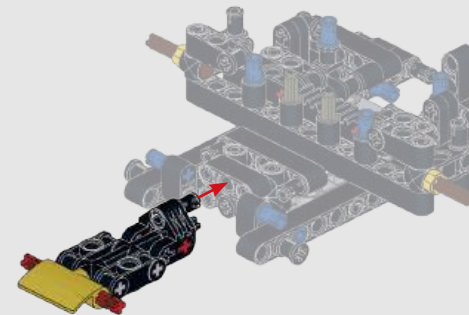



104

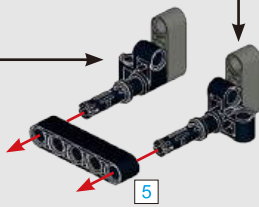
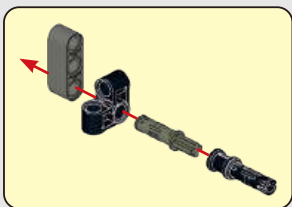
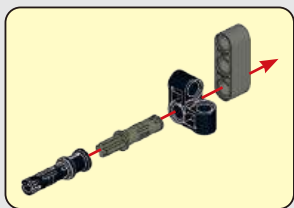

105

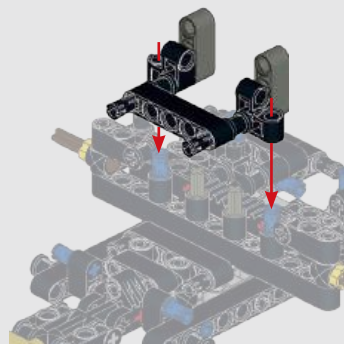

106

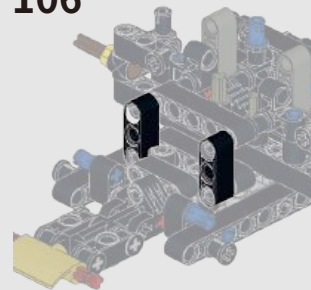

107

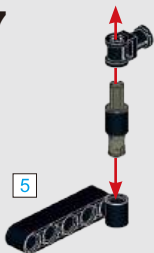

108

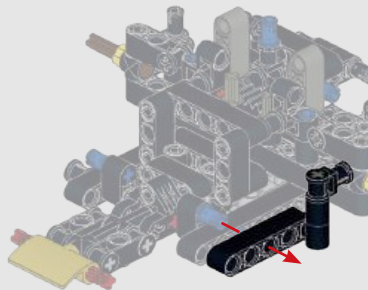

109

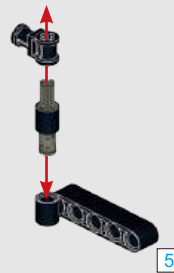

110

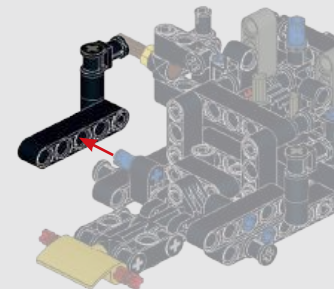



111

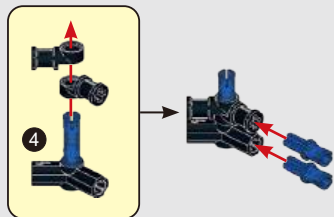

112

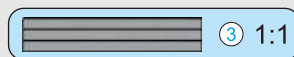
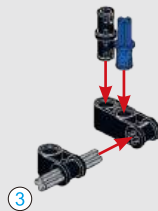

113

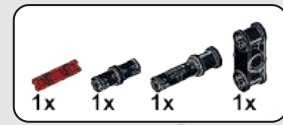

114

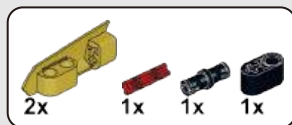
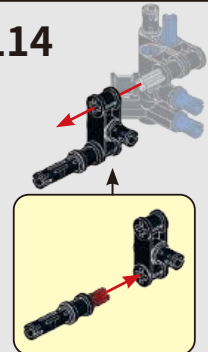

115

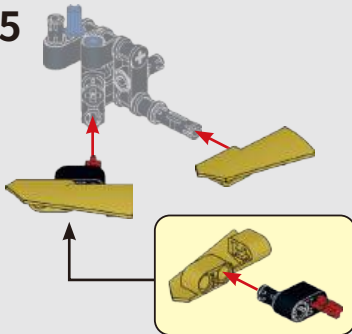

116

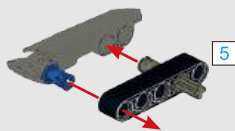

117

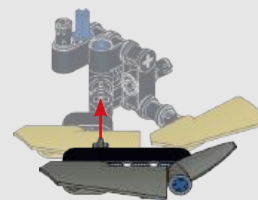

118

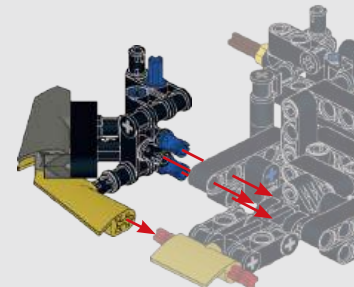

16



119

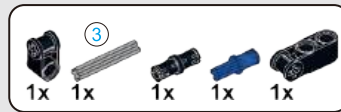
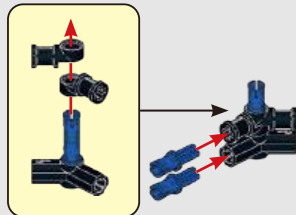

120

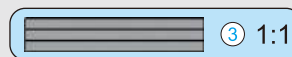
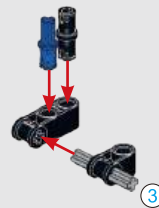

121

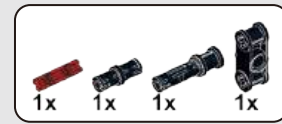

122

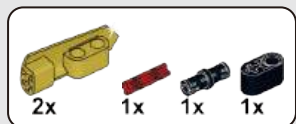
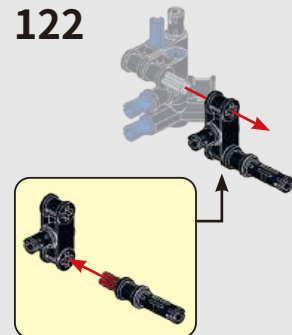

123

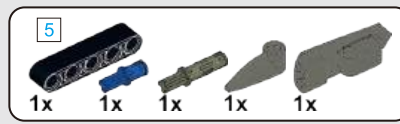
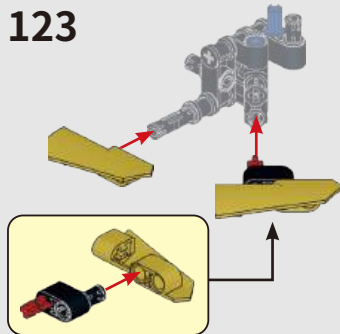

124

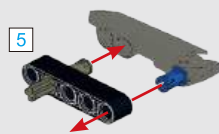

125

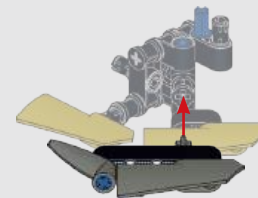

126

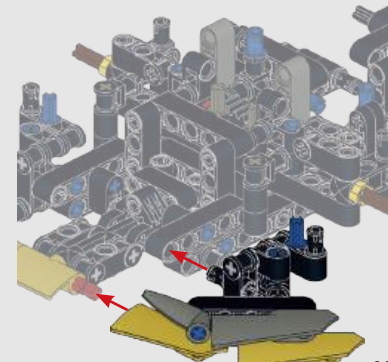

17



127

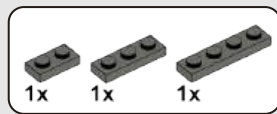

128

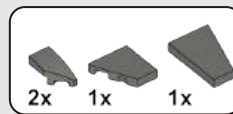
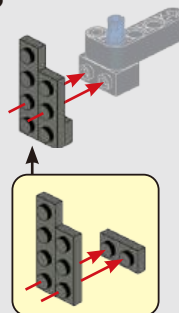

129

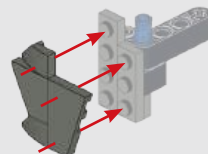

130

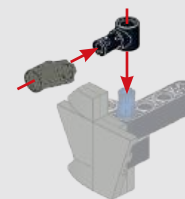

131

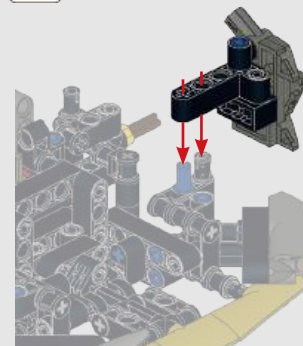

132

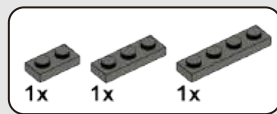

133

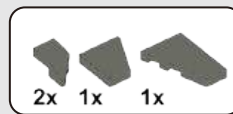
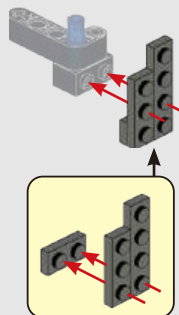

134

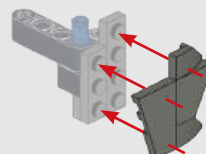

135

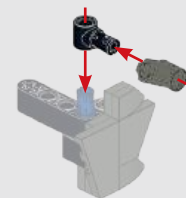

136

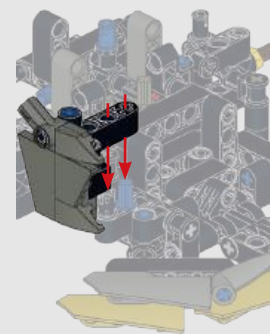

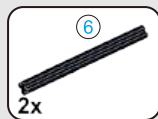

137

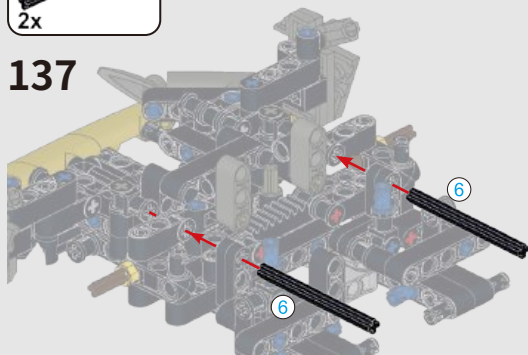

138

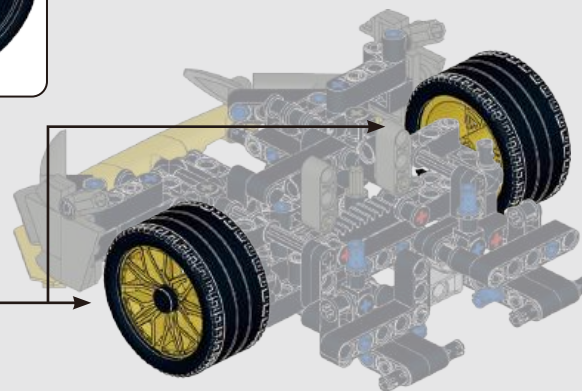
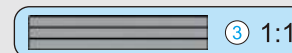
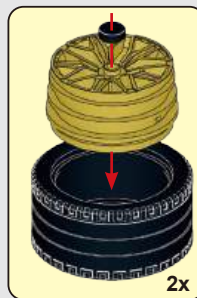

139

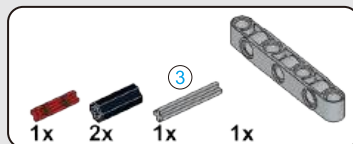
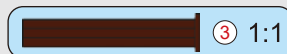
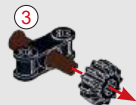

140

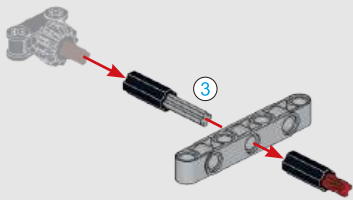

141

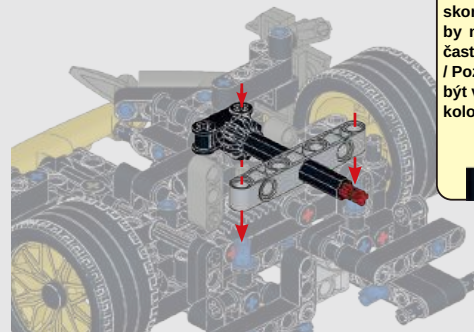

Note: This gear should be centered on the lower part and the front wheel should be corrected / Uwaga: To koło zębate powinno być wyśrodkowane w dolnej części i przednie koło należy skorygować / Poznámka: Tento převod by měl být vycentrován na spodní části a předné koleso by sa malo opravit / Poznámka: Toto ozubené kolo by mělo být vystředěno na spodní části a přední kolo by mělo být opraveno





142

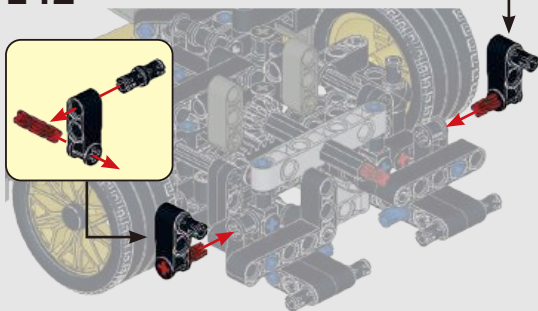

143

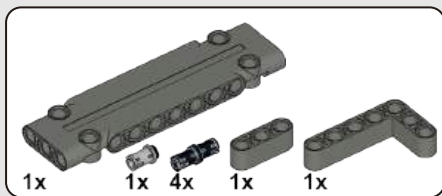
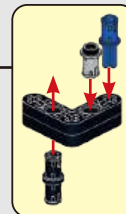
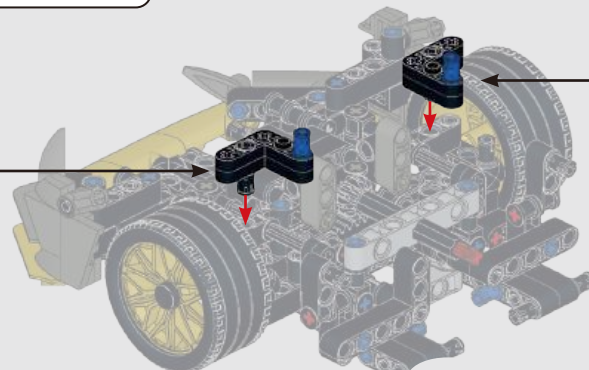
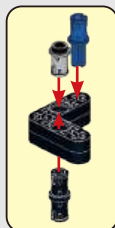

144

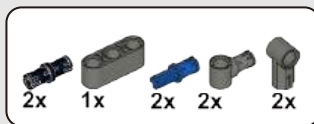
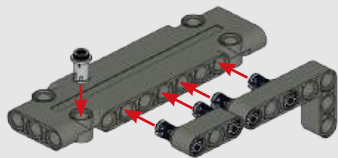

145

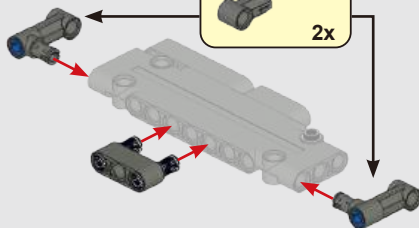
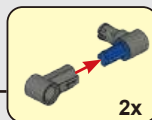

146

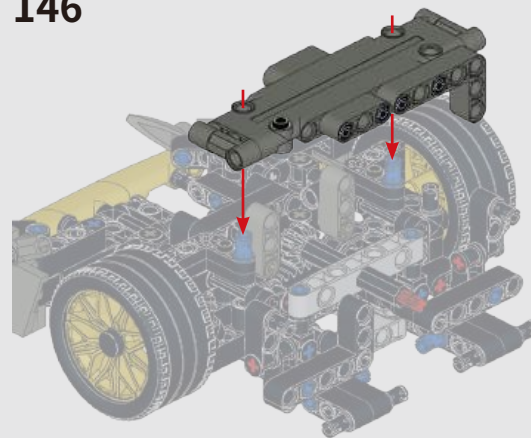

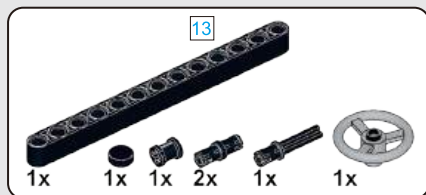

147

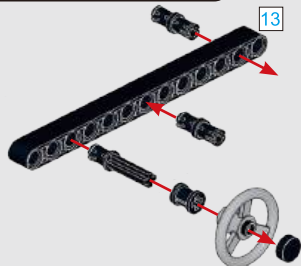

148

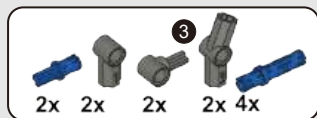
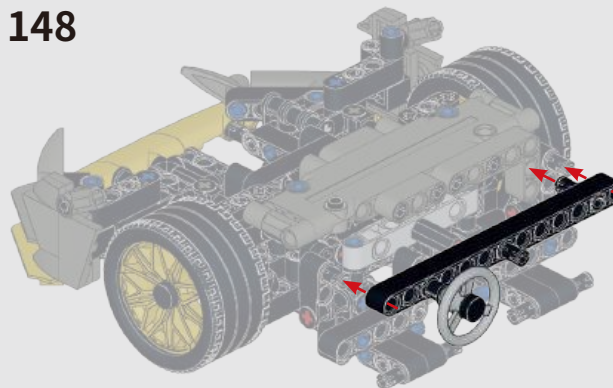

149

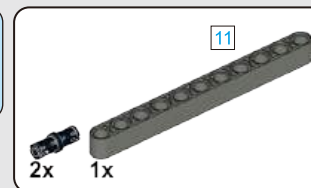
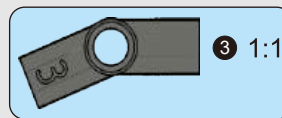
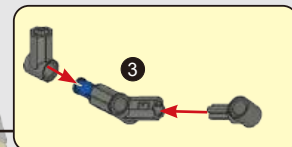
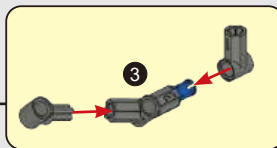
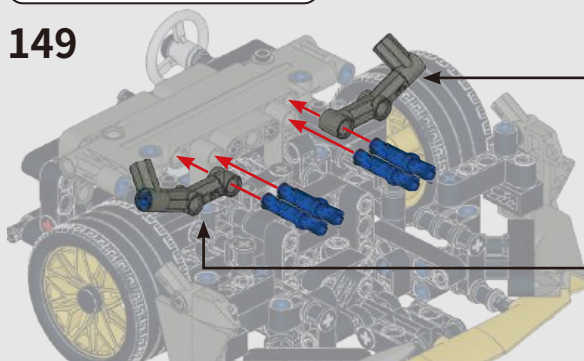

150

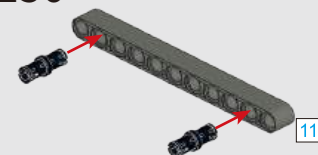

21



151

150

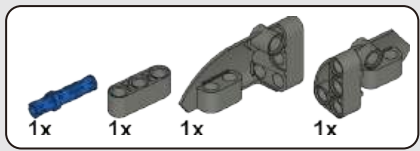
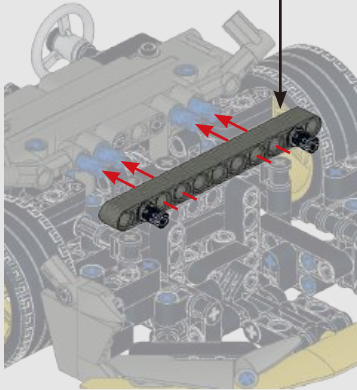

152

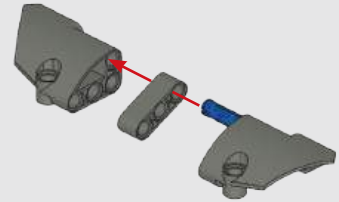

153

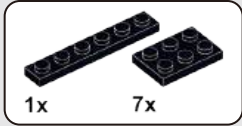
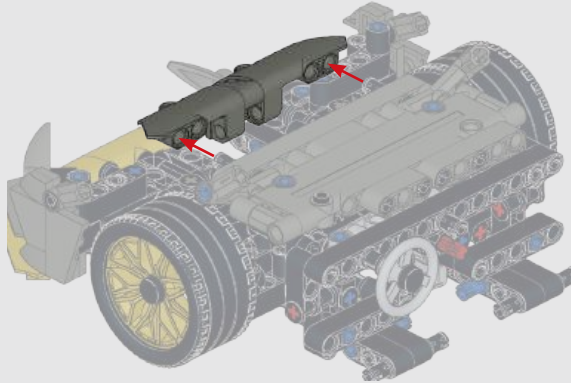

154

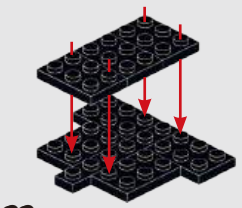

22

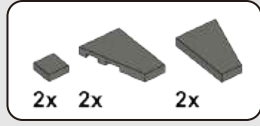

155

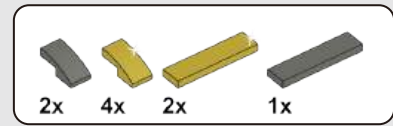
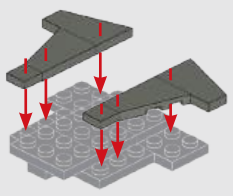

156

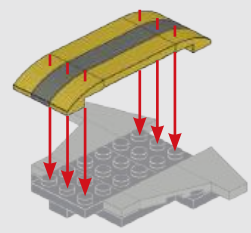

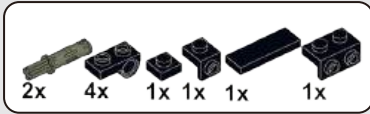

157

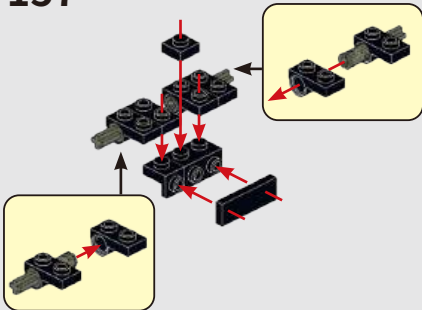

158

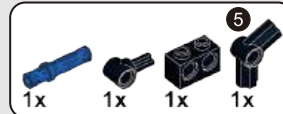
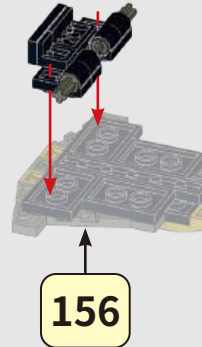

159

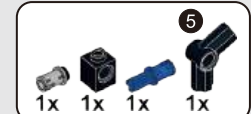
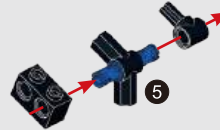

160

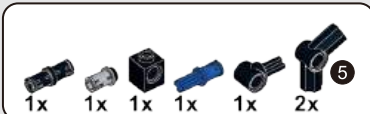
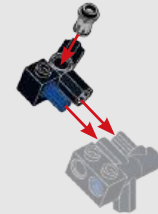

161

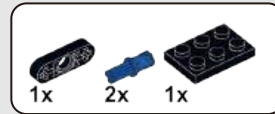
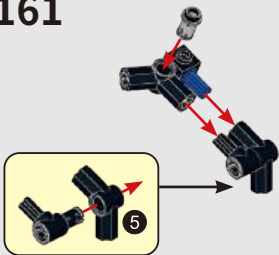

162

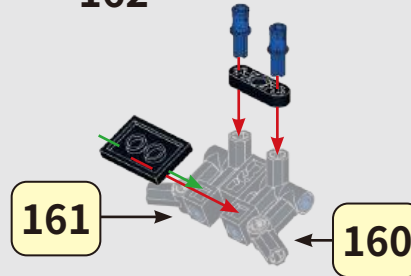

163

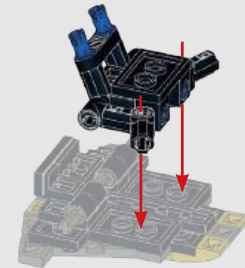

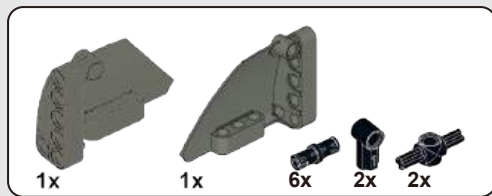

164

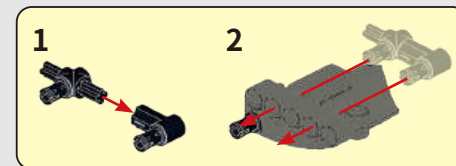
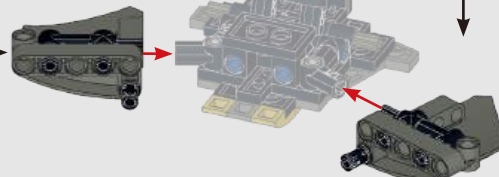
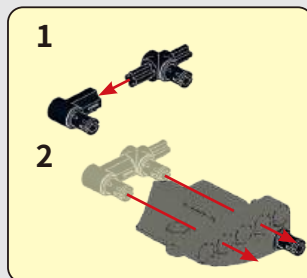

165

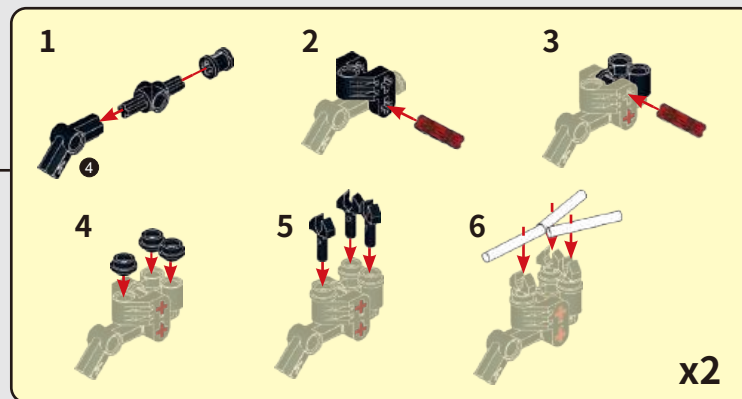
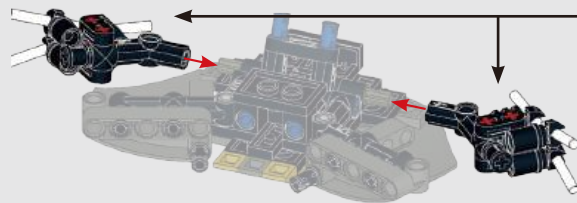

24

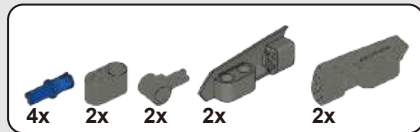

166

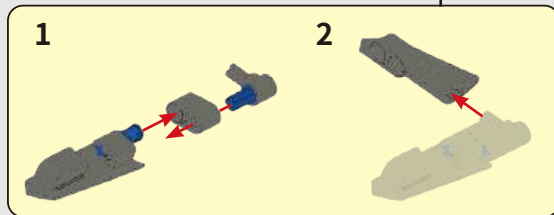
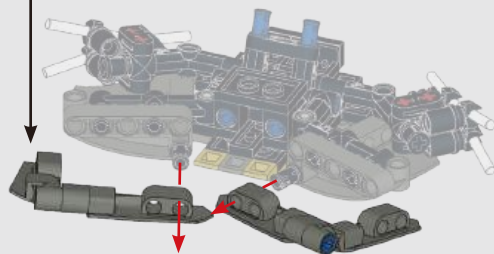
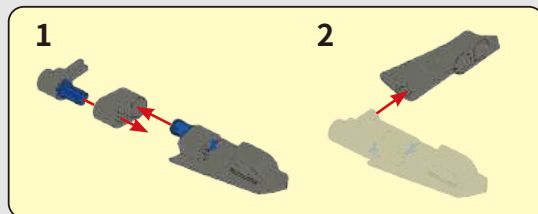

167

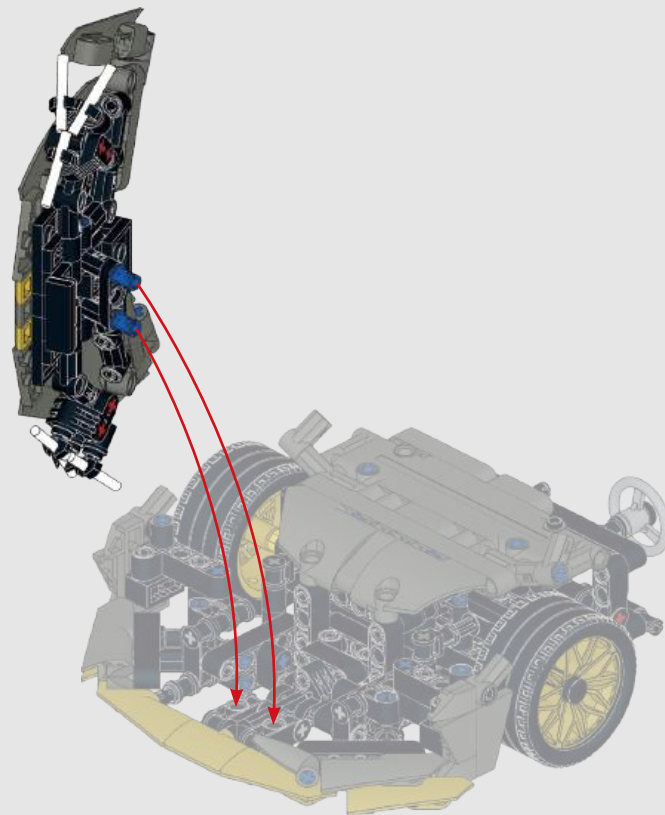

25

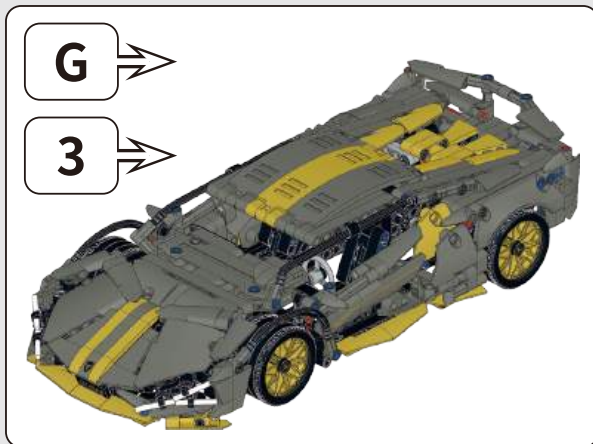

168

167

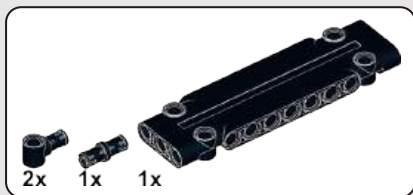
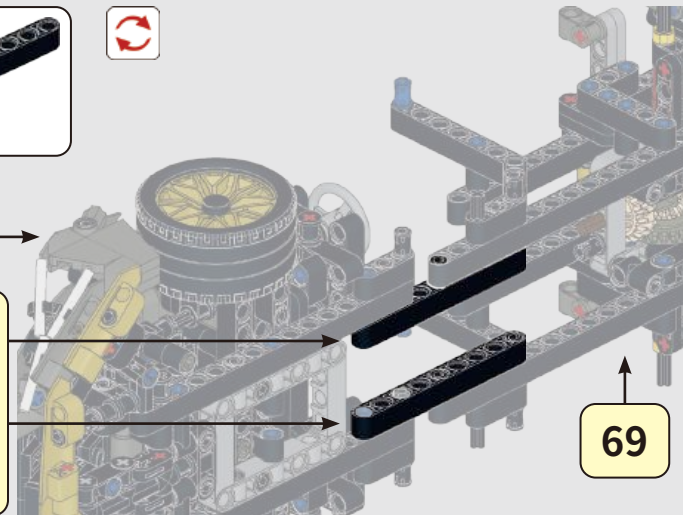
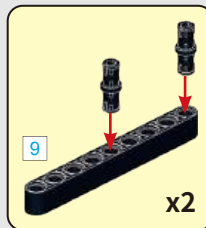

169

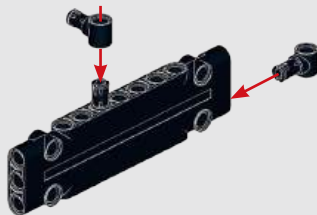

26



170

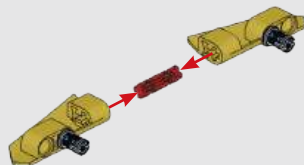

171

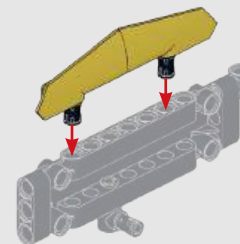



172

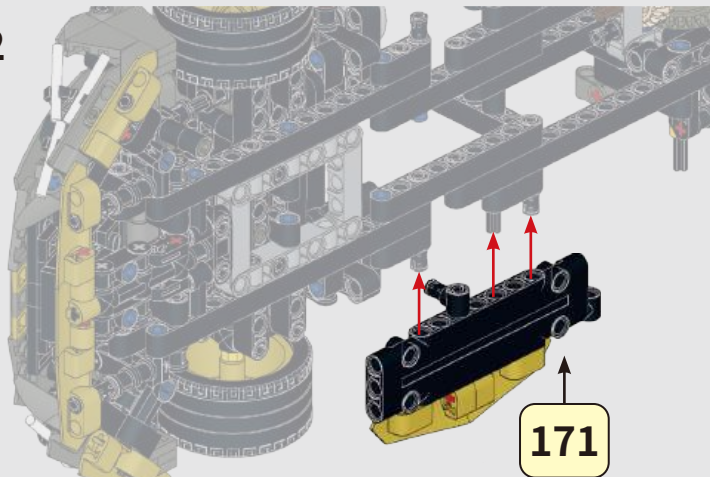

173



174

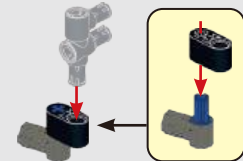

175

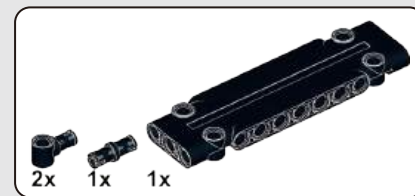
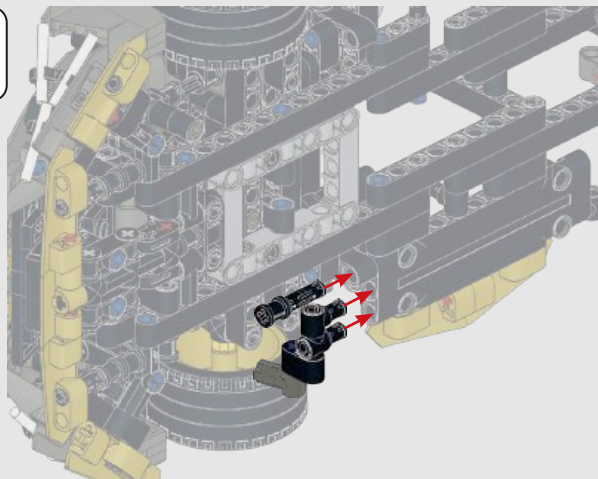

176

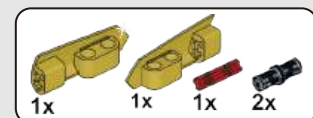
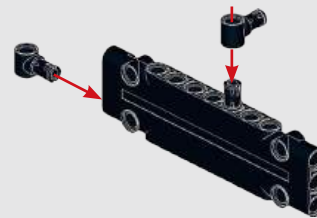

177

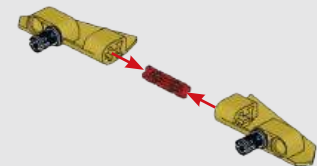

27



178

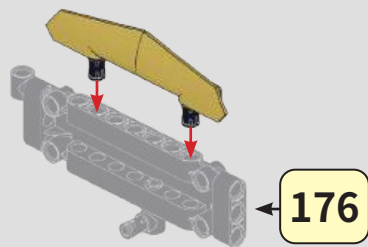

179

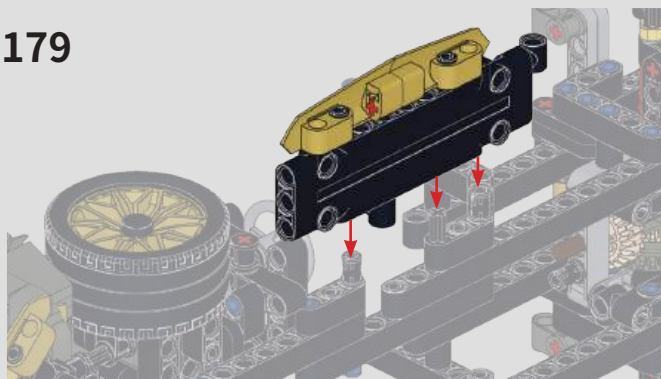

180

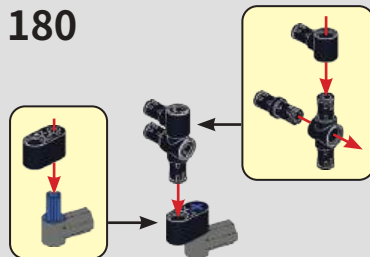

181

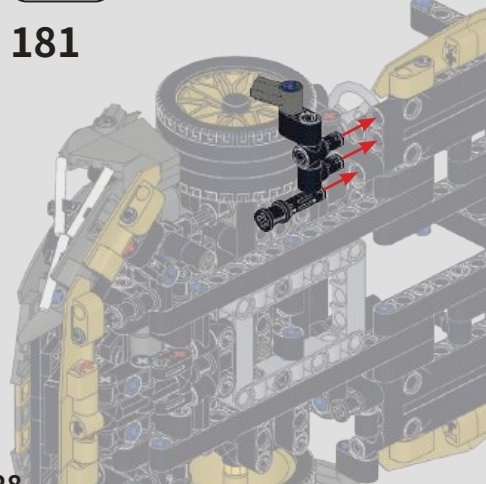

182

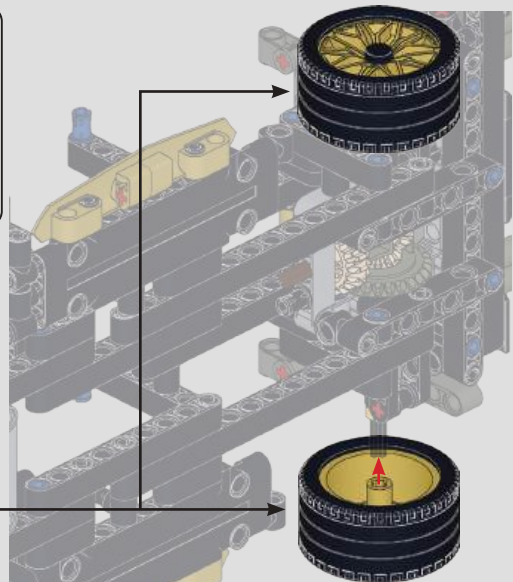
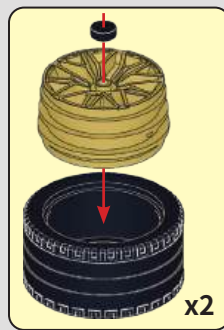

28

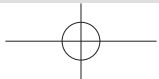

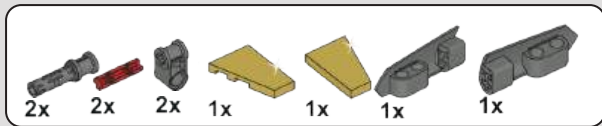

183

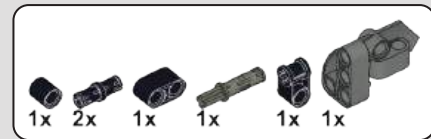
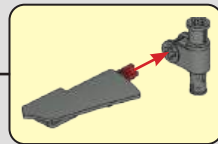
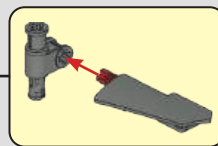
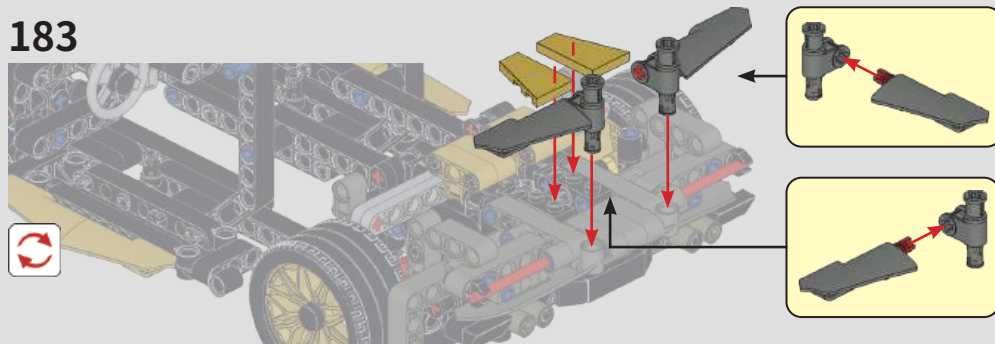

184

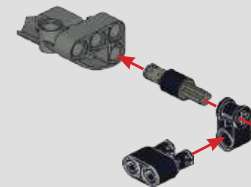

185

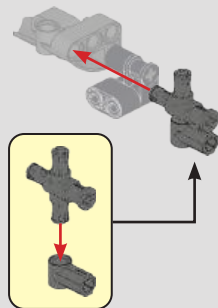

186

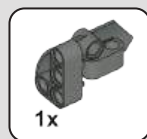
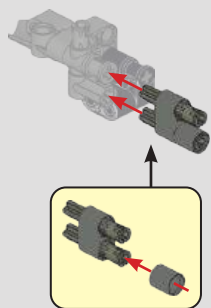

187

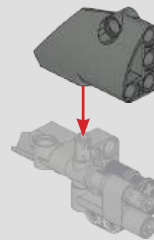

188

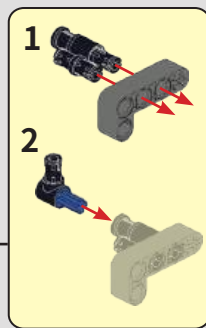
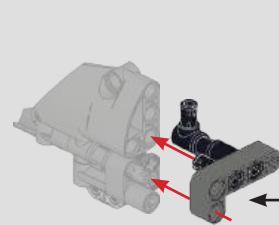

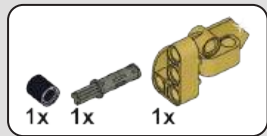

189

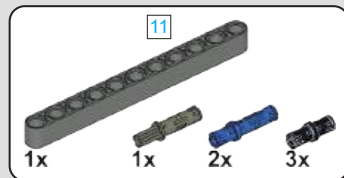
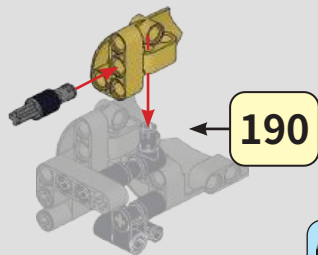

190

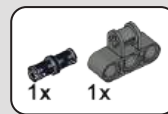
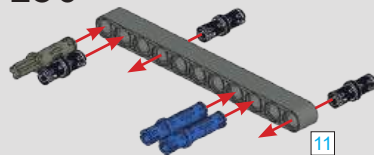

191

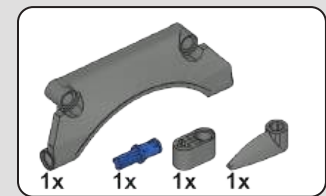
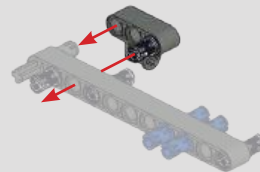

192

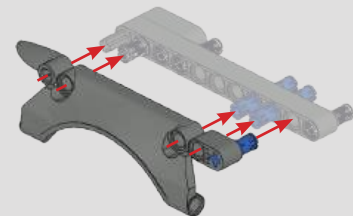

193

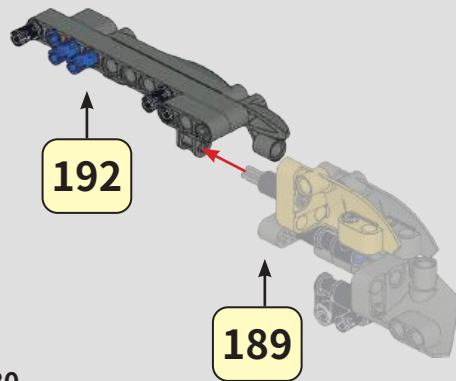

194

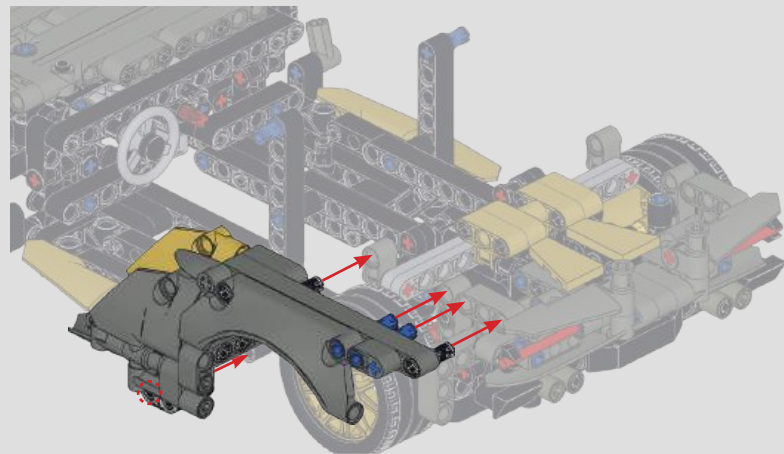



195

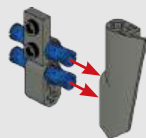

196

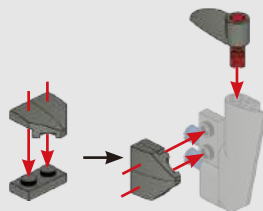

197

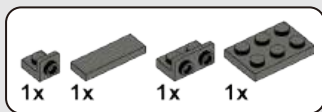
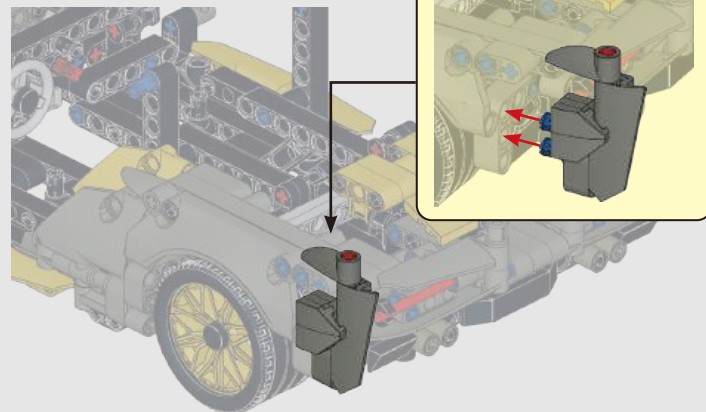

198

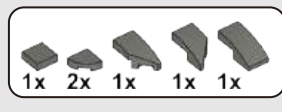
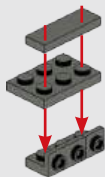

199

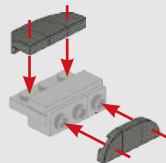

200

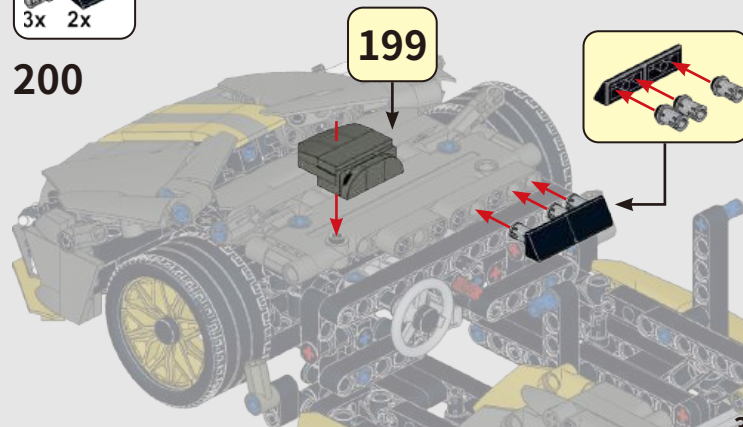

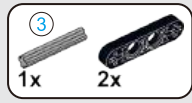

201

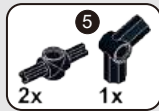

202



203



204



205

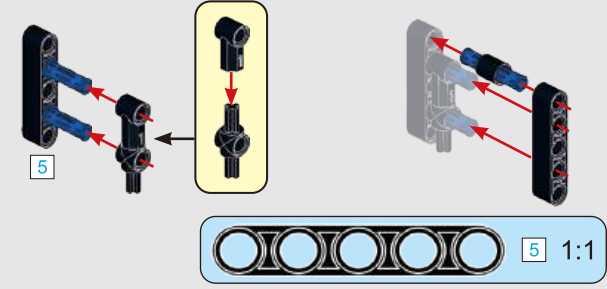
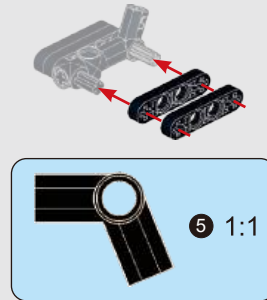
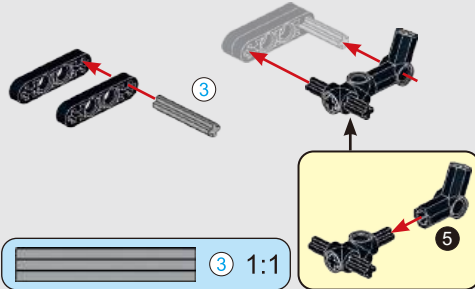

206

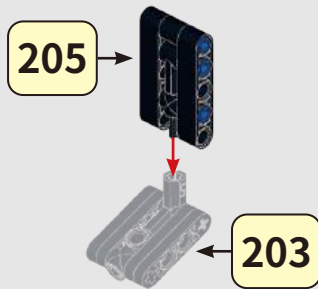

207

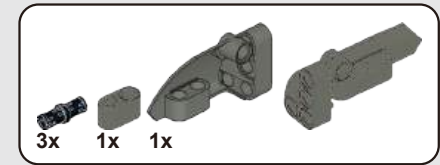
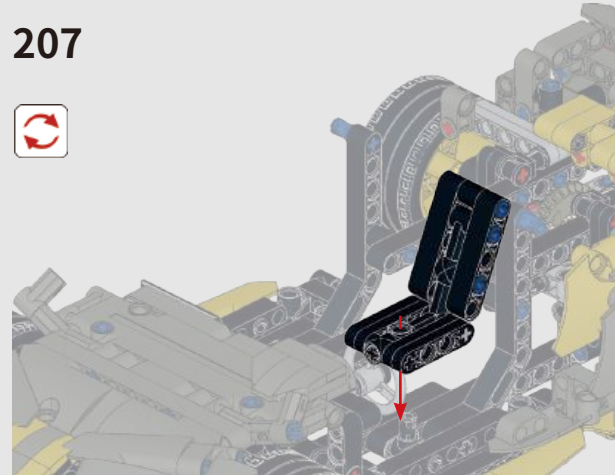

208

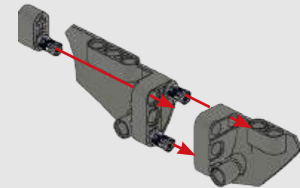

32



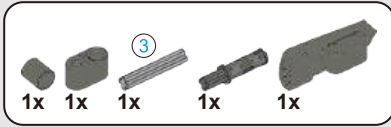

209

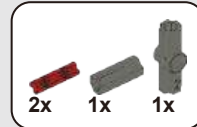
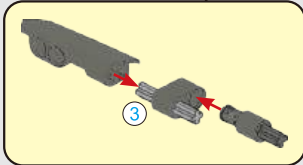
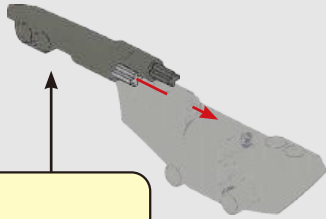

210

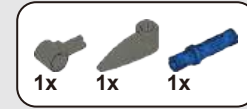
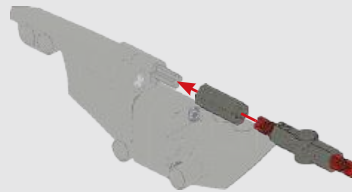

211

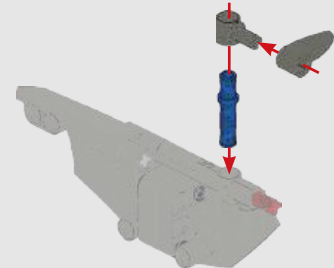

212

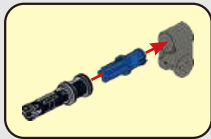

213

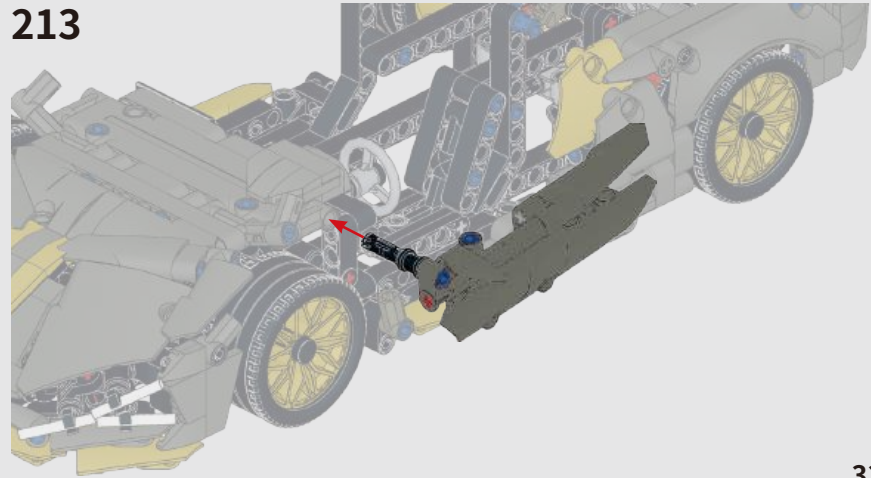

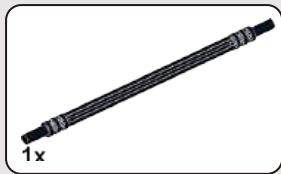

214

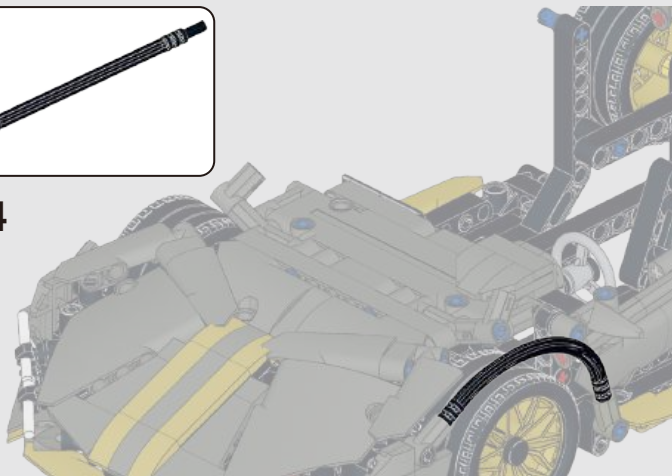

215

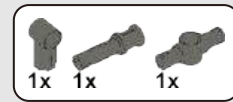
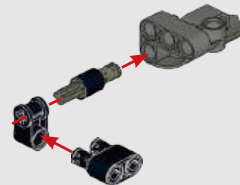

216

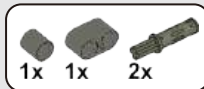
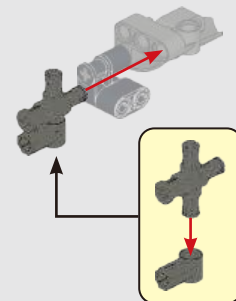

217

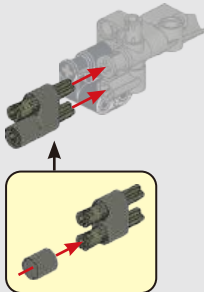

34

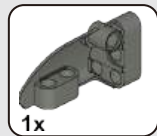

218

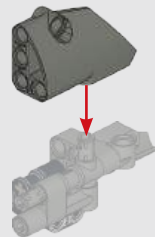

219

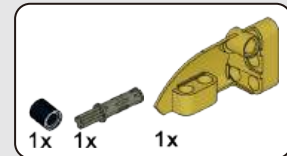
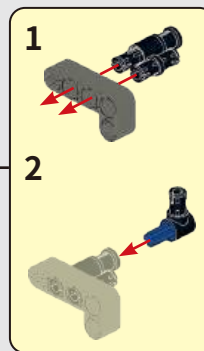
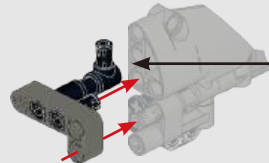

220

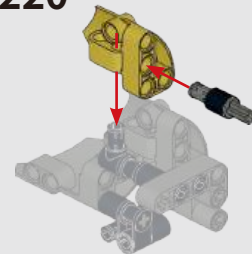



227

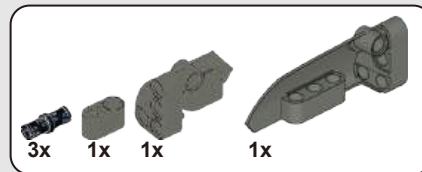
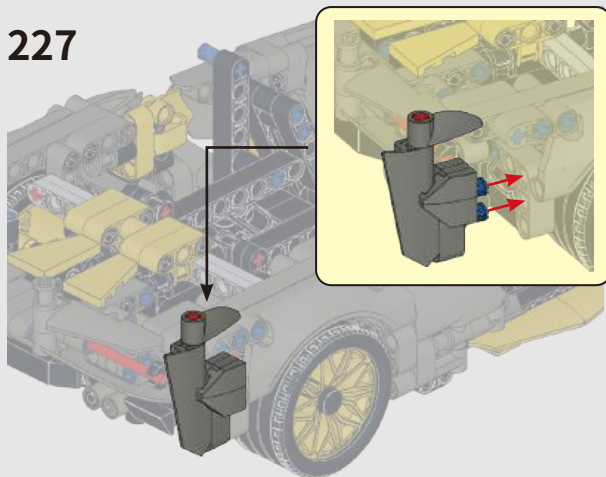

228

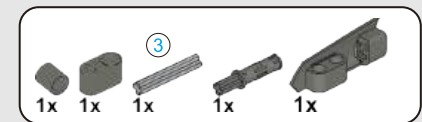
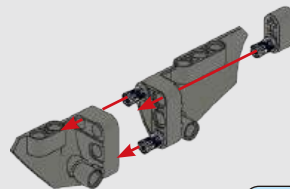

229

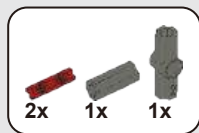
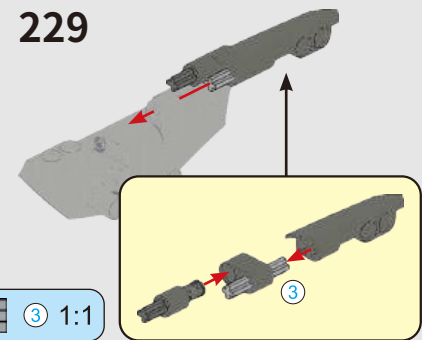

230

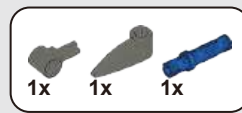
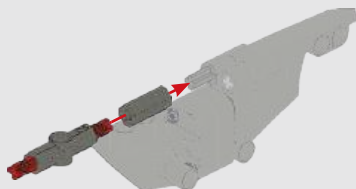

231

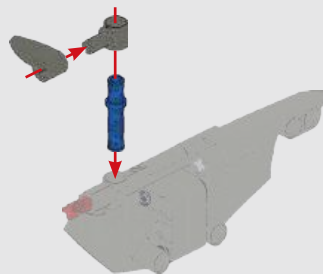

232

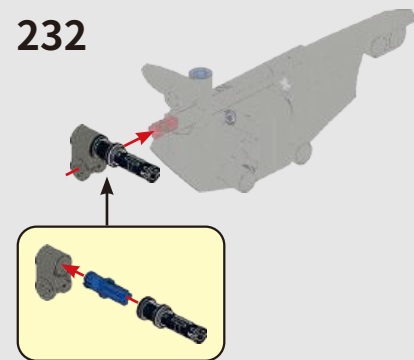



233

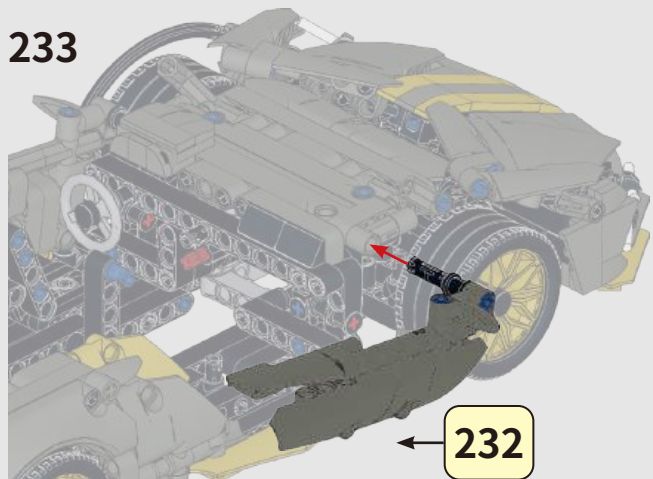

234

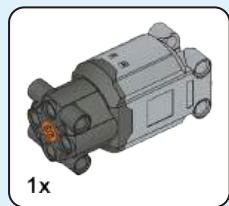
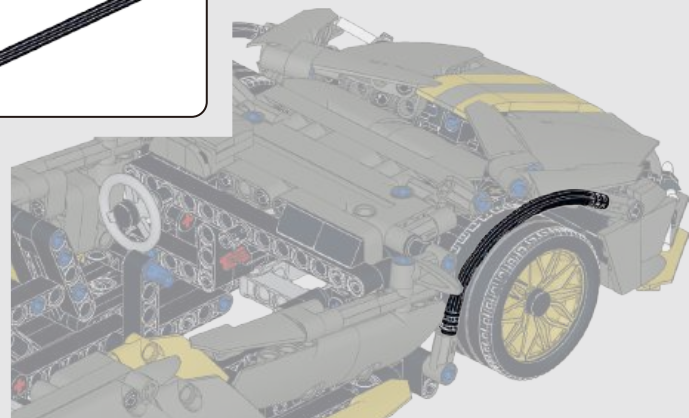

235

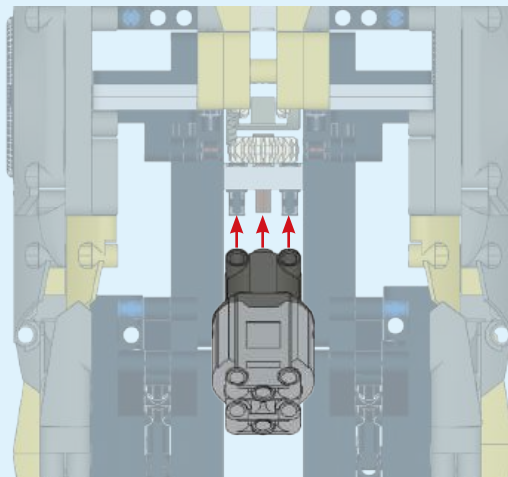

Note: The blue page shows the installation steps of the power version / Uwaga: niebieska strona pokazuje kroki instalacji wersji zdalnej / Poznámka: Modrá stránka s kroky vzdialenejšej inštalácie / Poznámka: Modrá stránka s kroky vzdálenejší instalace

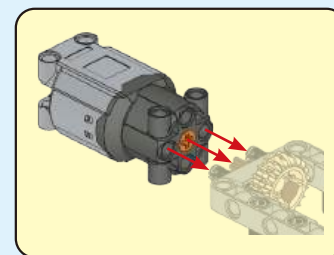

37



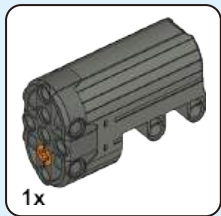

236

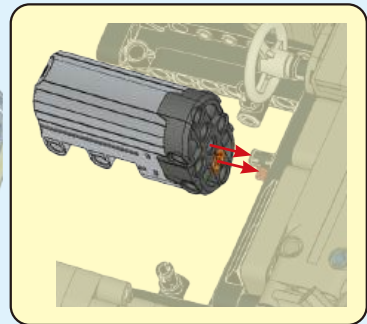
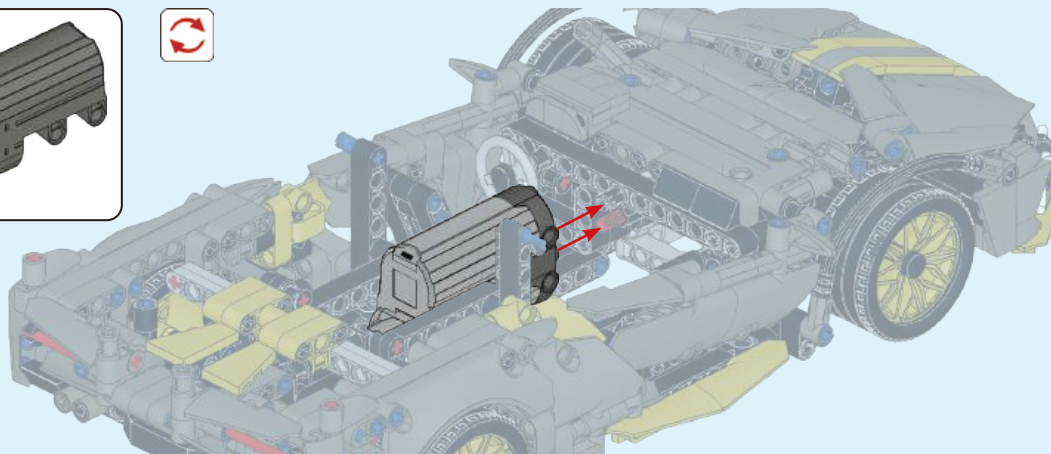

237

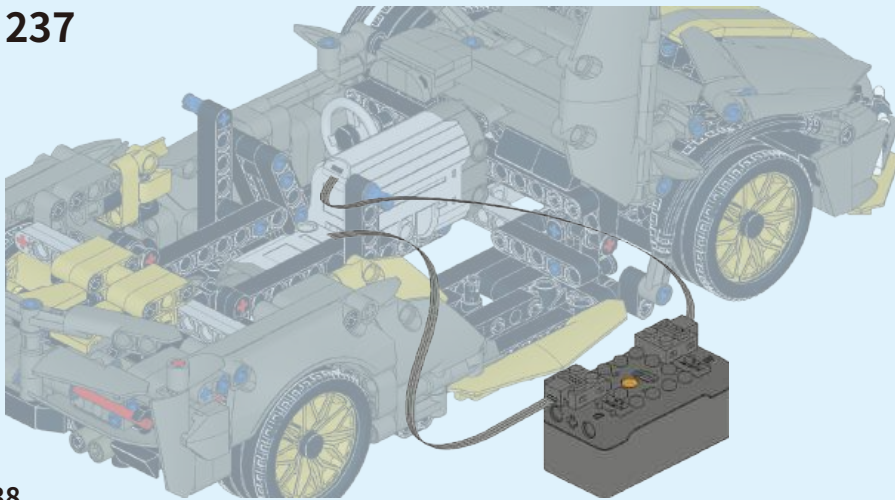

38

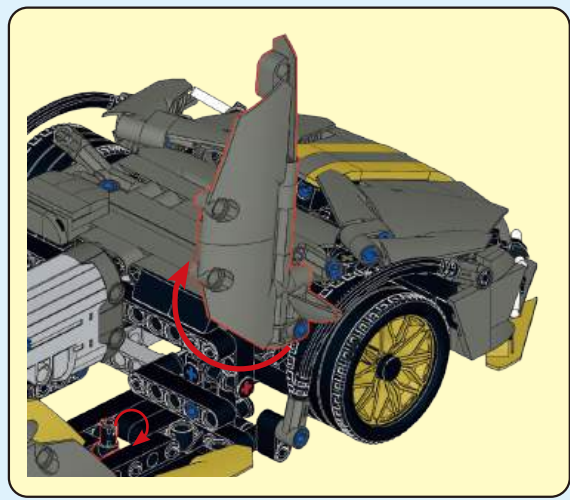

238

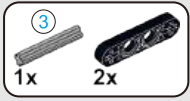
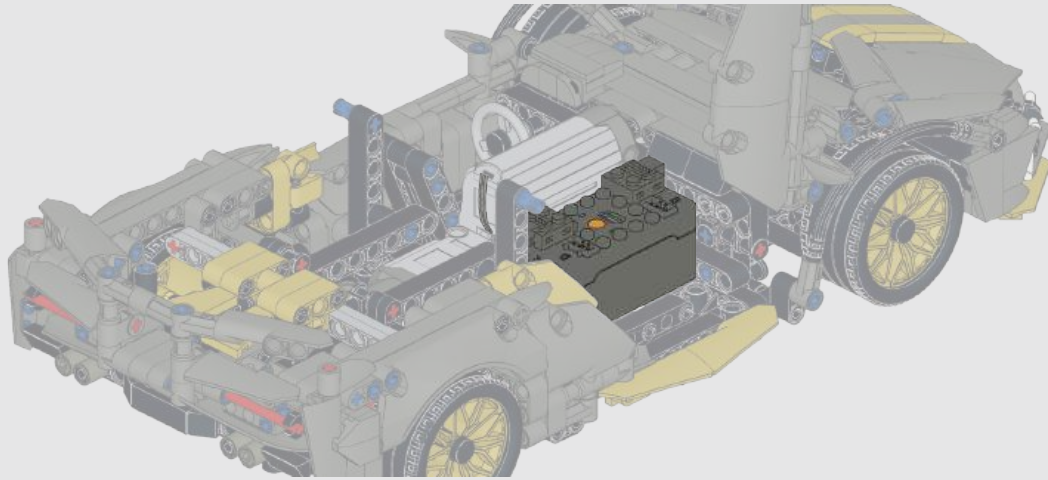

239

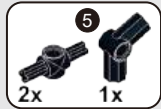
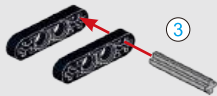

240

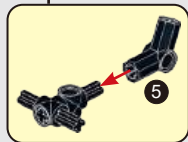
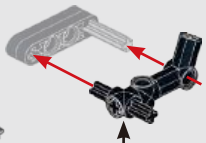

241

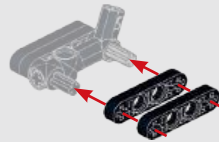

242

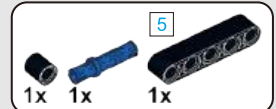
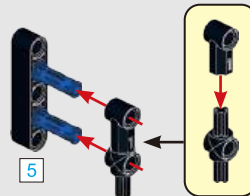

243

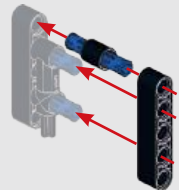



244

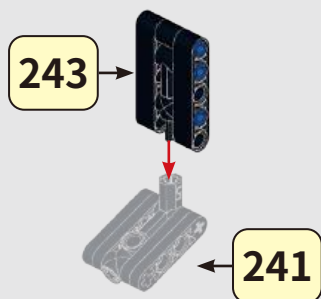

245

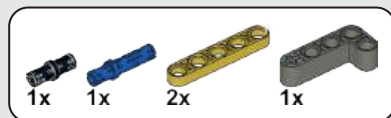
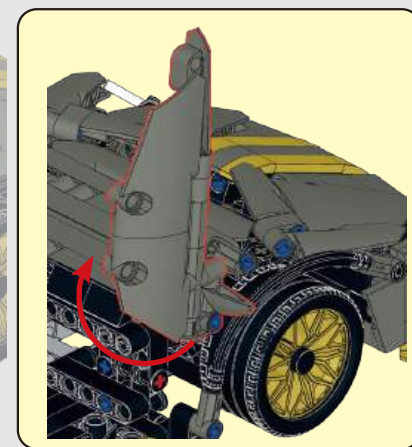
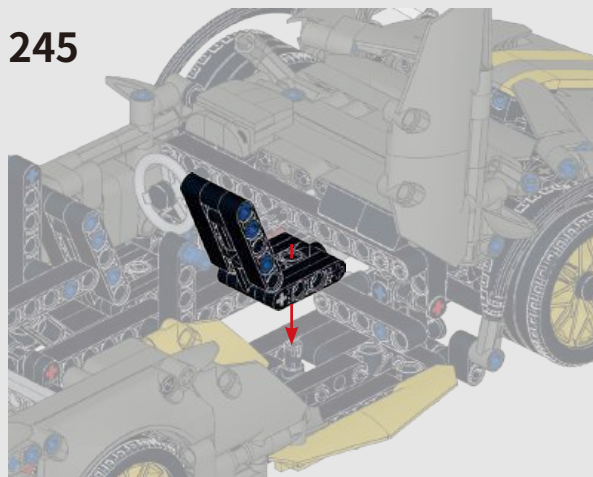

246

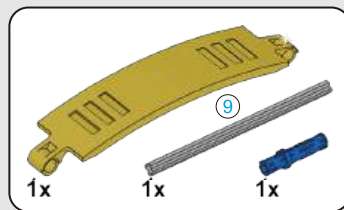
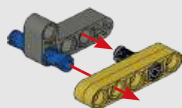

247

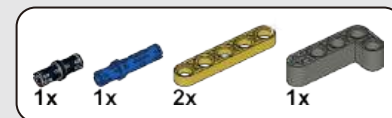
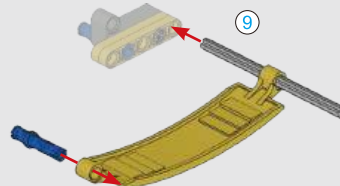

248

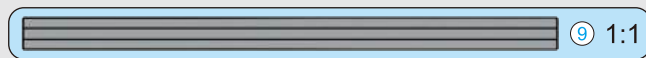
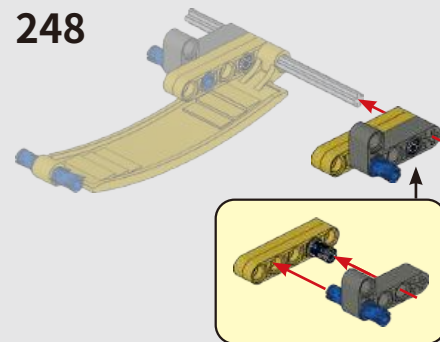

40



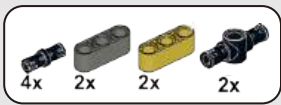

249

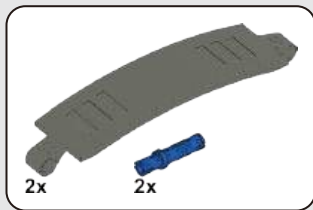
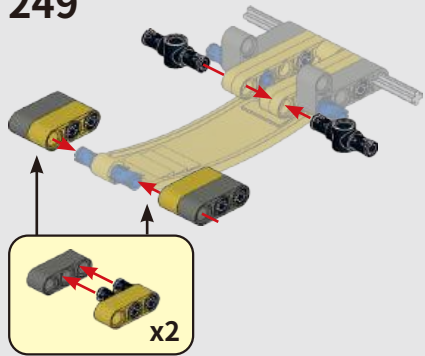

250

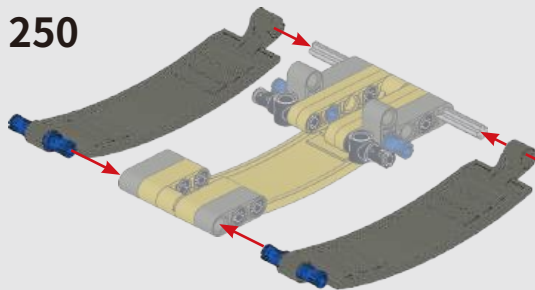

251

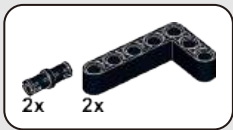
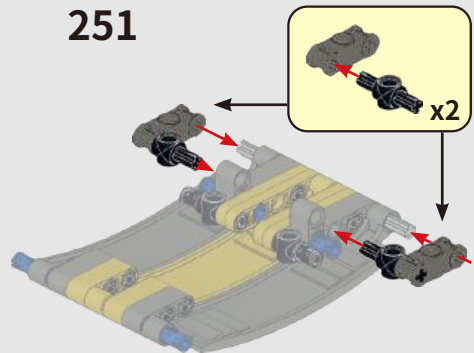

252

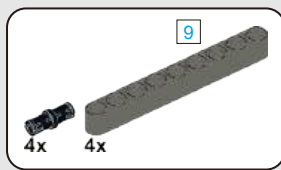
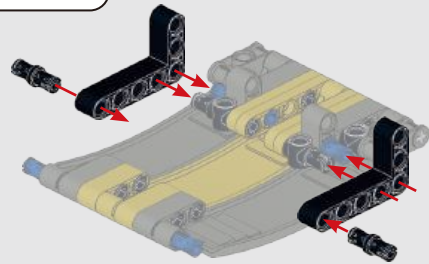

253

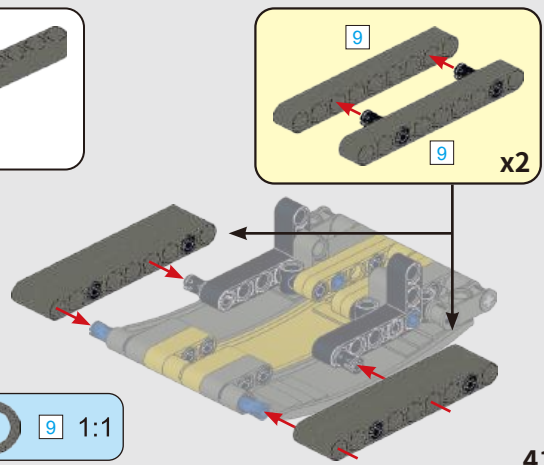



4x

254

253

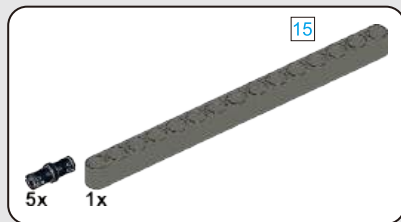
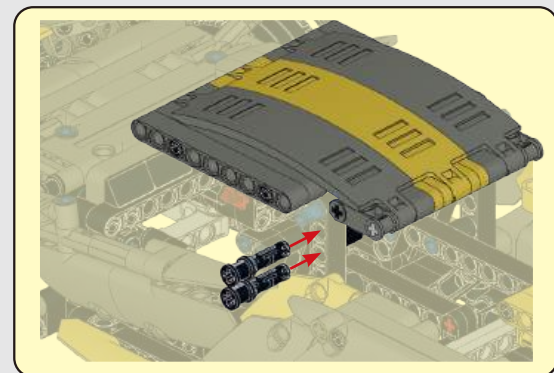
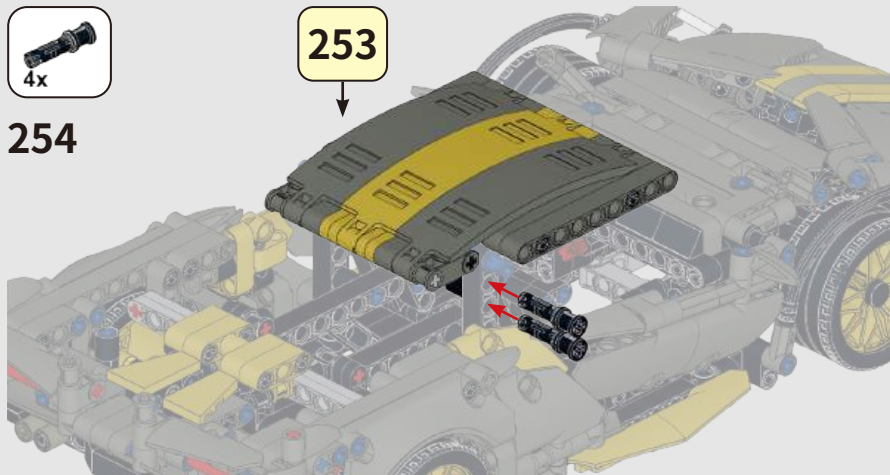

15

5x 1x

255

42

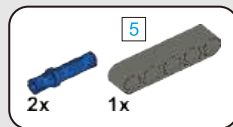

5

2x 1x

256

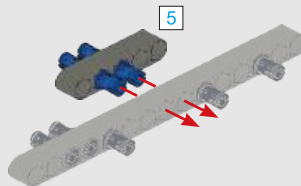

5

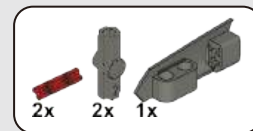

2x 2x 1x

257

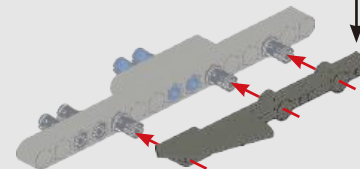
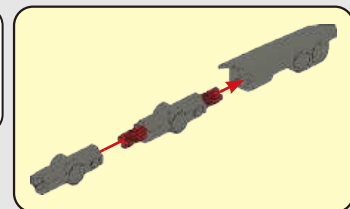



2x

258

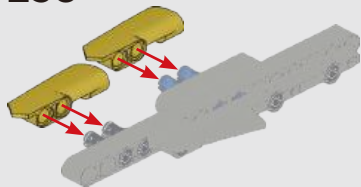

259

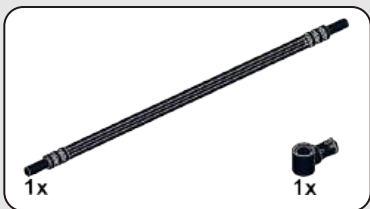
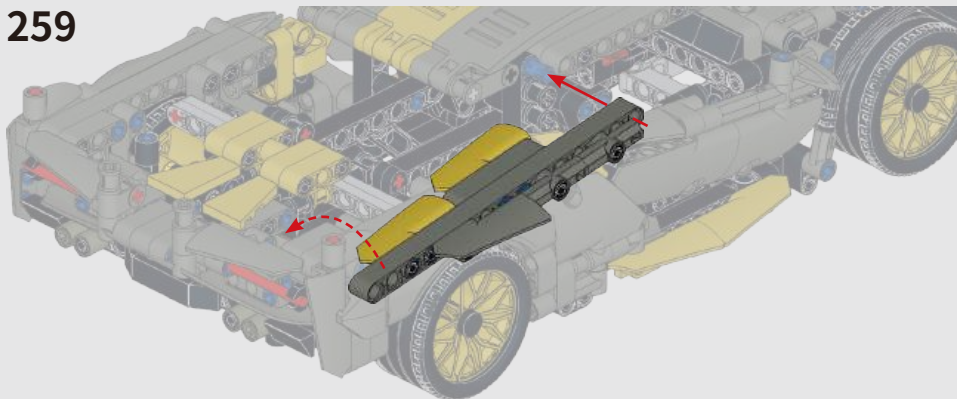

1x

1x

260

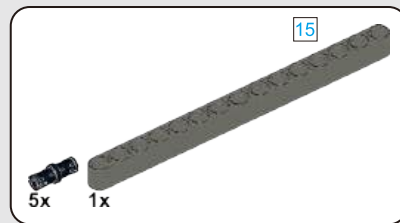
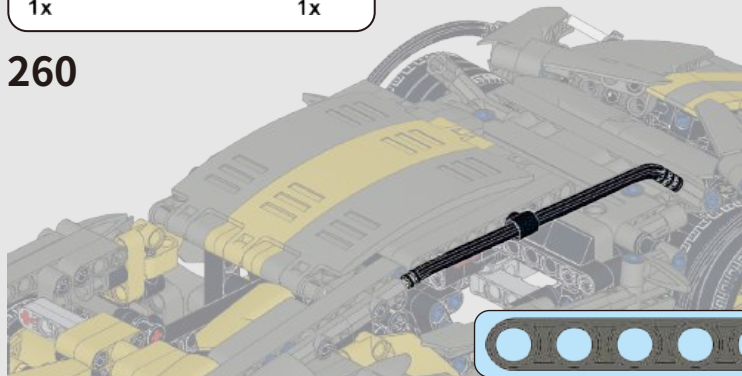

15

5x

1x

261



15



15

1:1

43

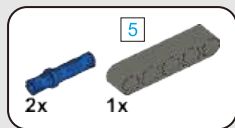

262

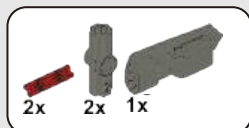
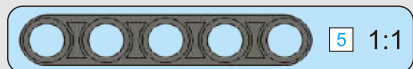
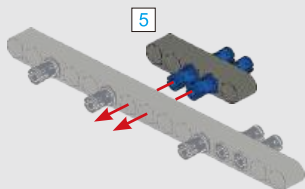

263

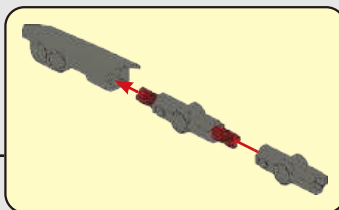
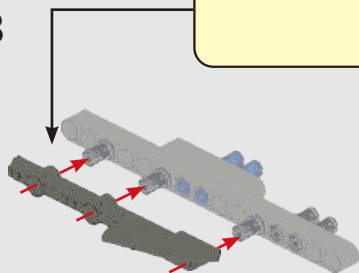

264

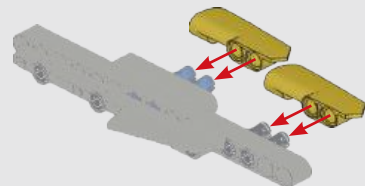

265

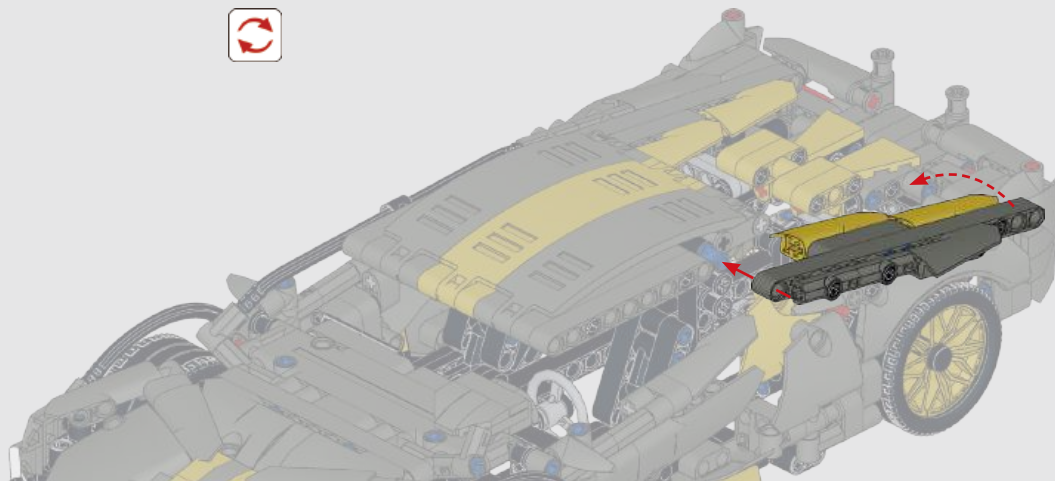

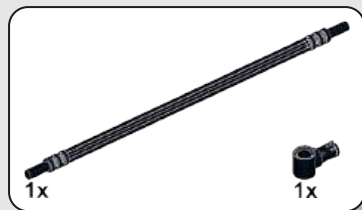

266

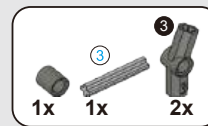
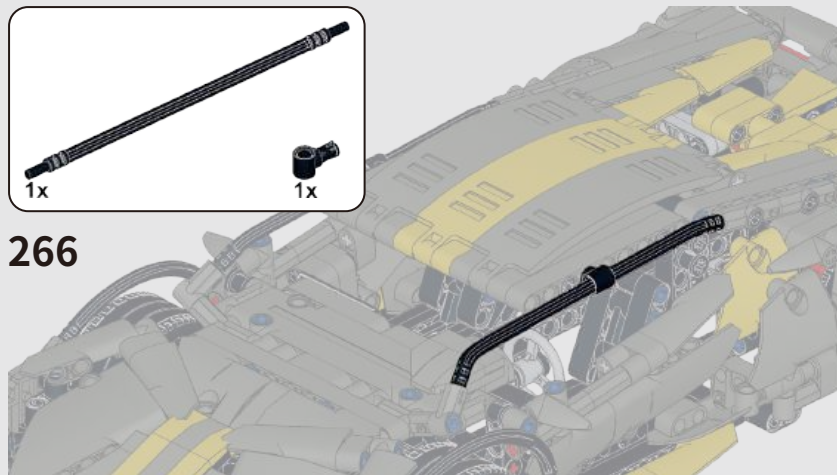

267

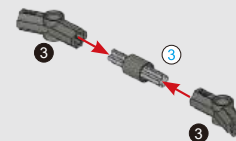

268

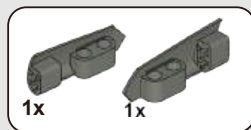
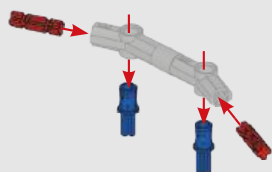

269

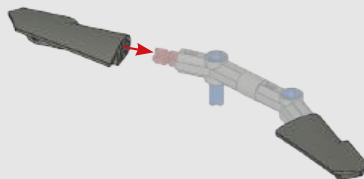

270

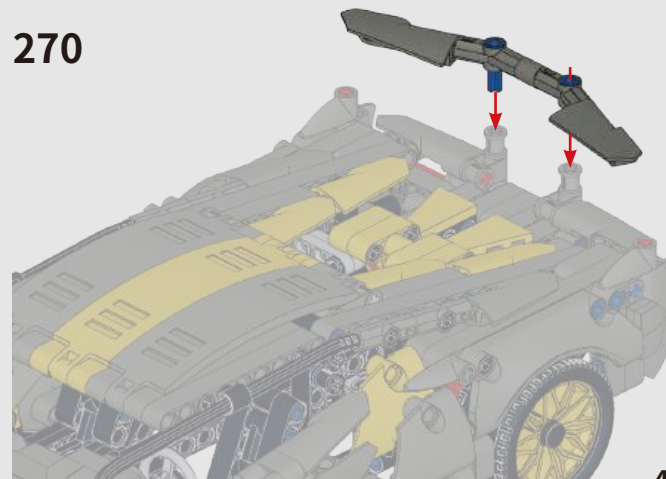

45

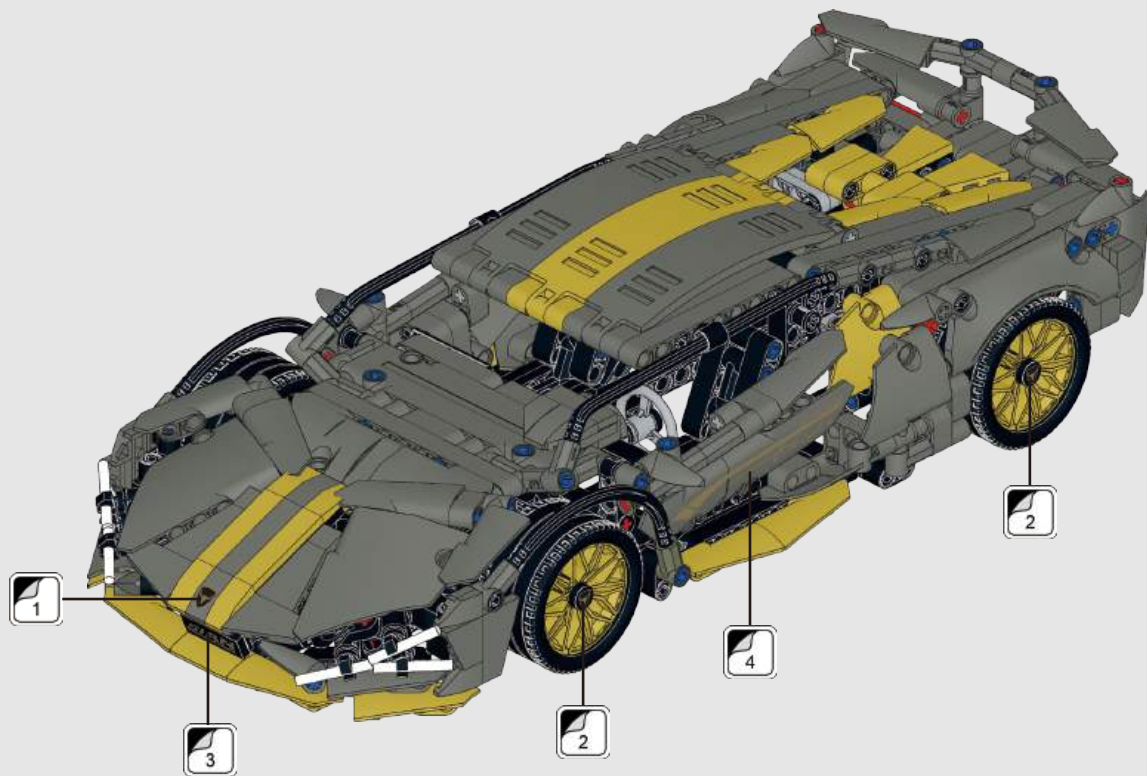





Note: This is a step-by-step description of converting a static version to a dynamic version / Uwaga: jest to opis krok po kroku konwersji wersji statycznej na wersję dynamiczną / Poznámka: Toto je podrobný popis převodu statické verze na dynamickou verzi

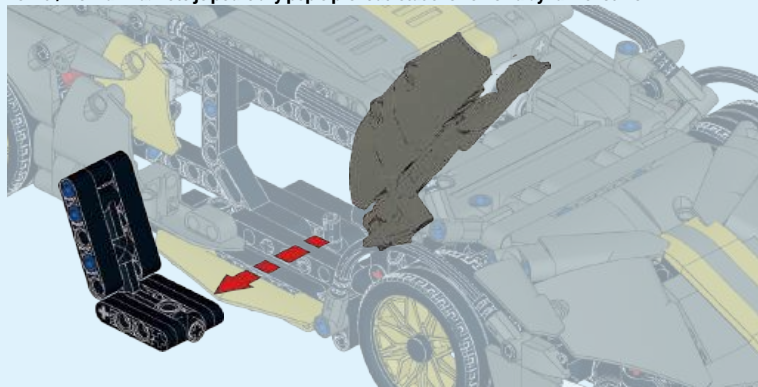

The seat needs to be slightly steered before it can be pulled out / Fotelik należy lekko obrócić, zanim będzie można go wyciągnąć / Pred vytiahnutím je potrebné sedadlo mierne natočiť / Před vytažením je třeba sedadlo mírně natočit

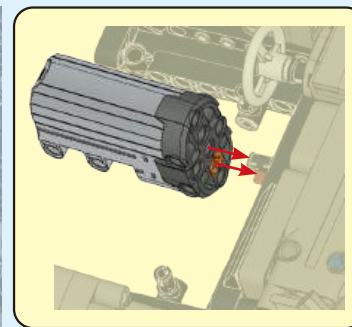
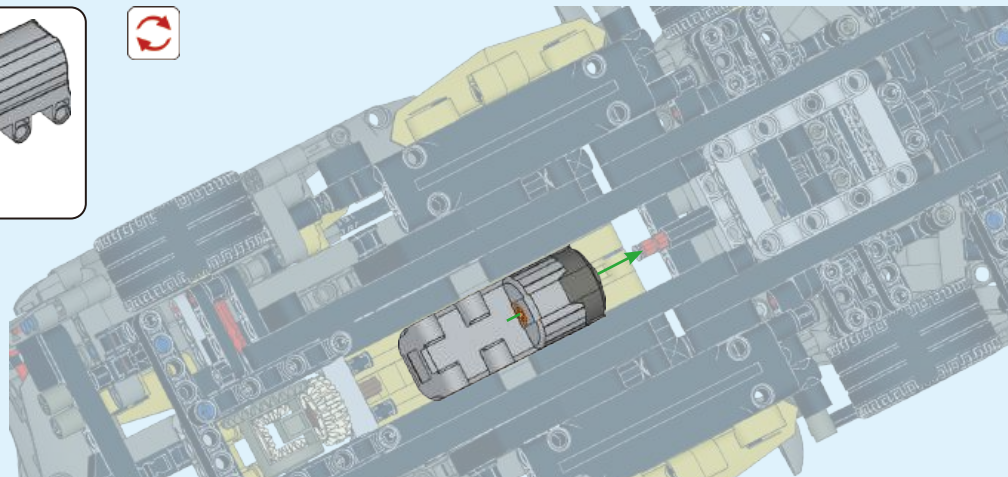
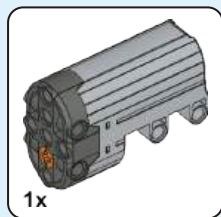
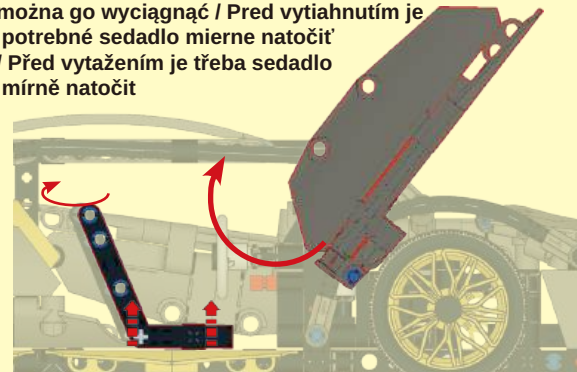

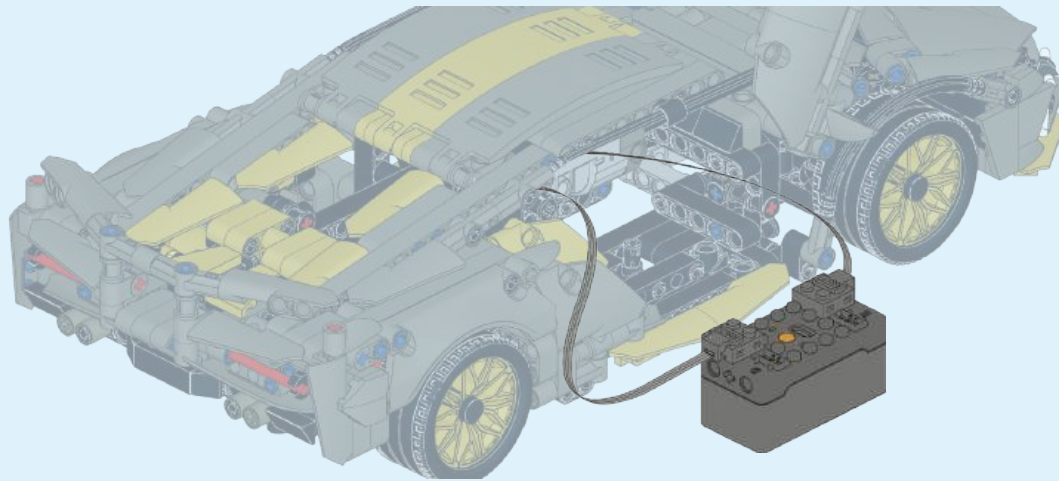
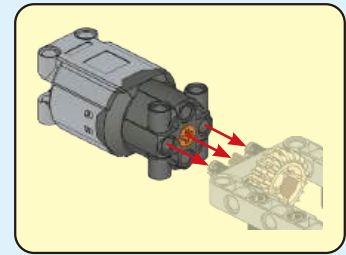
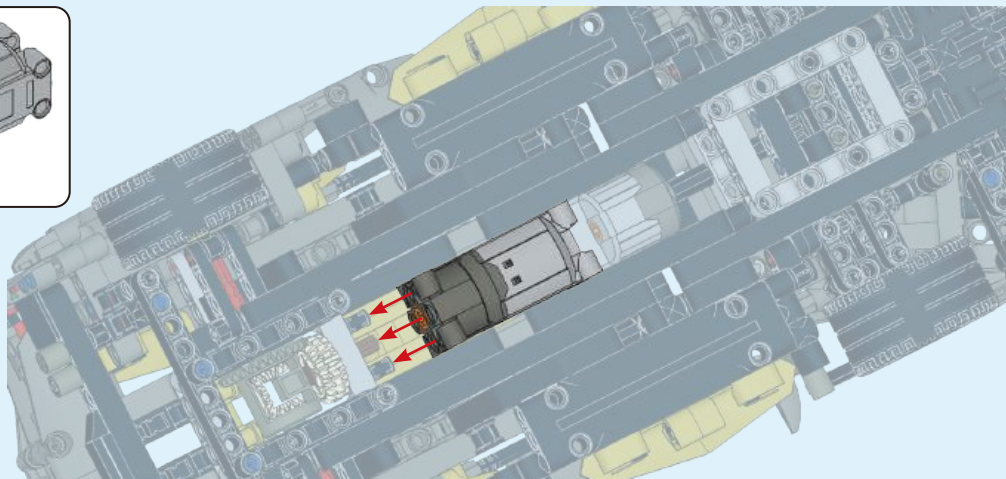
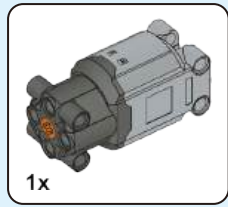

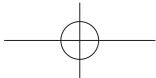

1:14 PLATED METAL



20231113.07

