

MACHINE PLAYER

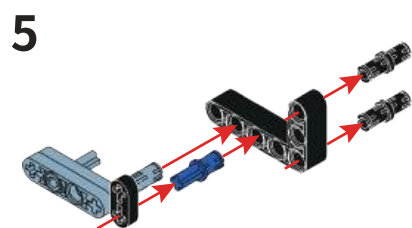

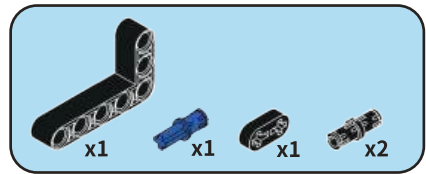

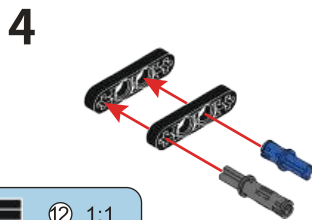
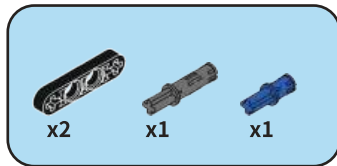
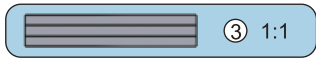
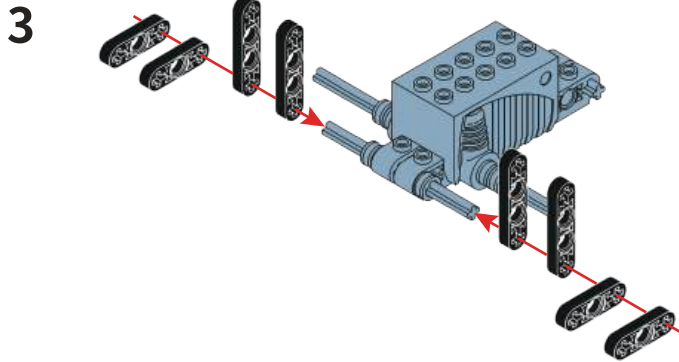
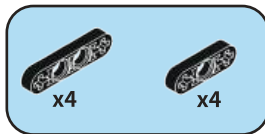
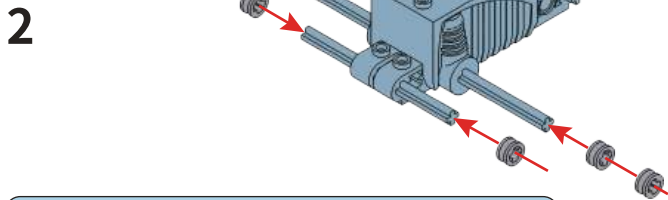
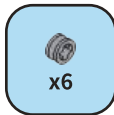
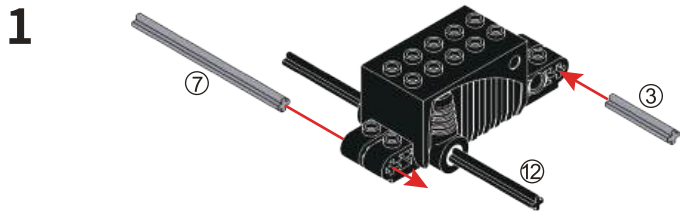
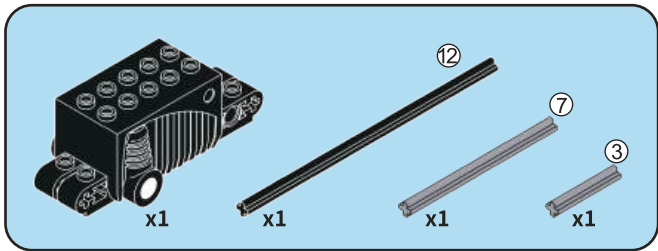
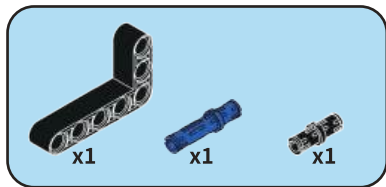

6

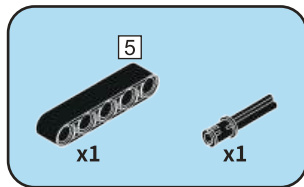
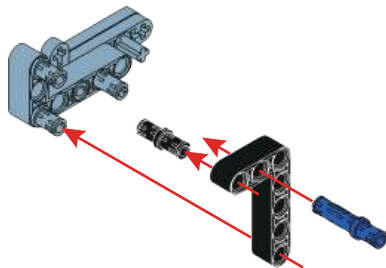

7

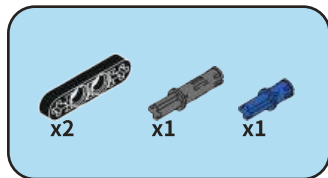
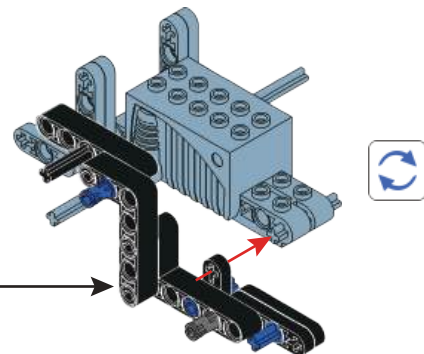
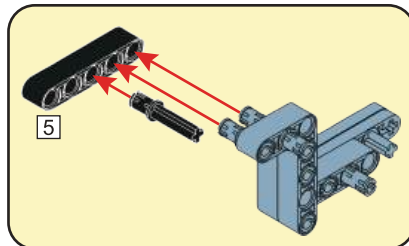

8

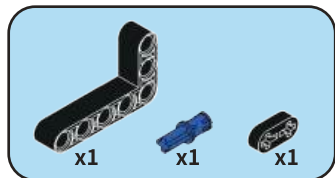
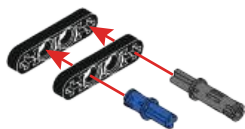

9

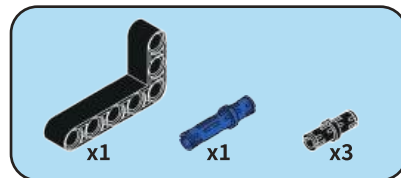
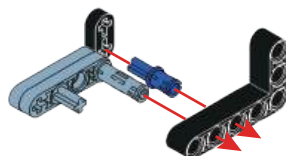

10

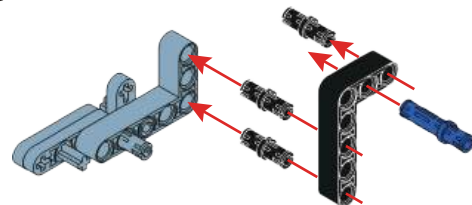

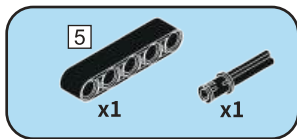

11

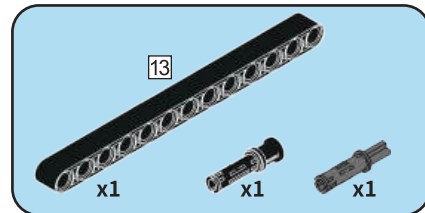
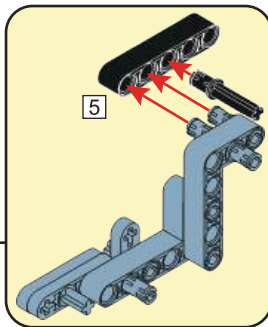
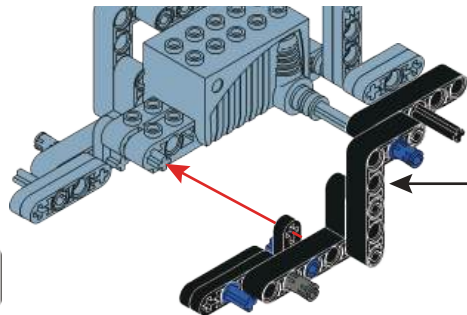

12

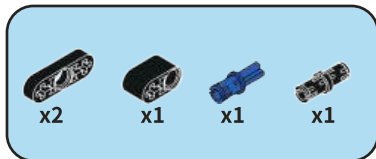
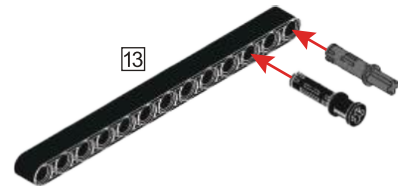

13

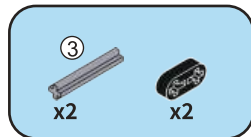
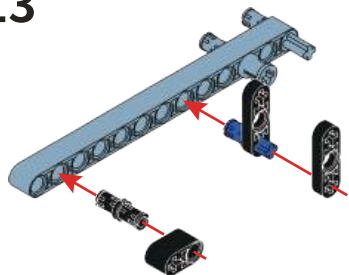

14

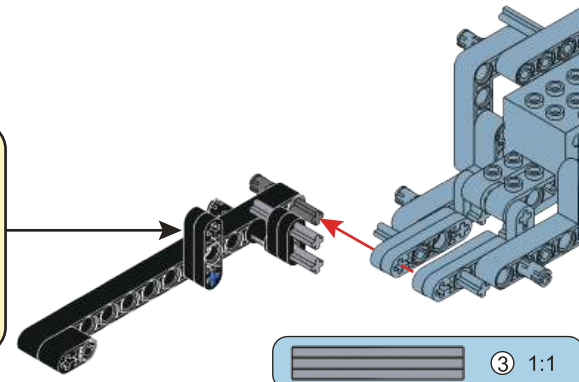
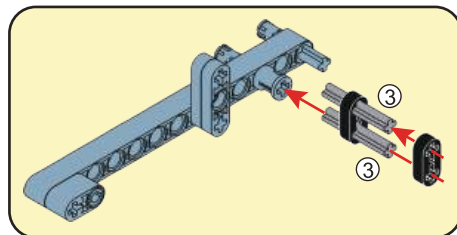

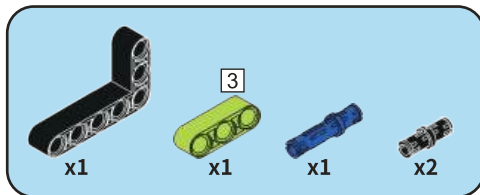

15

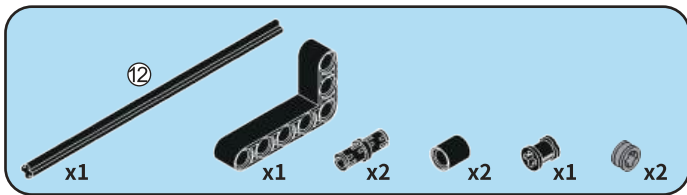
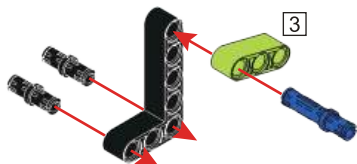

16

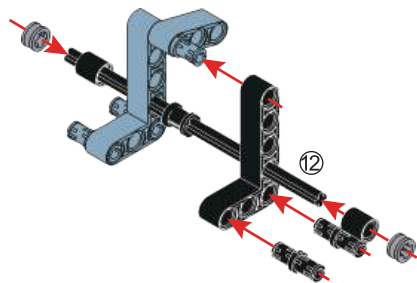

16

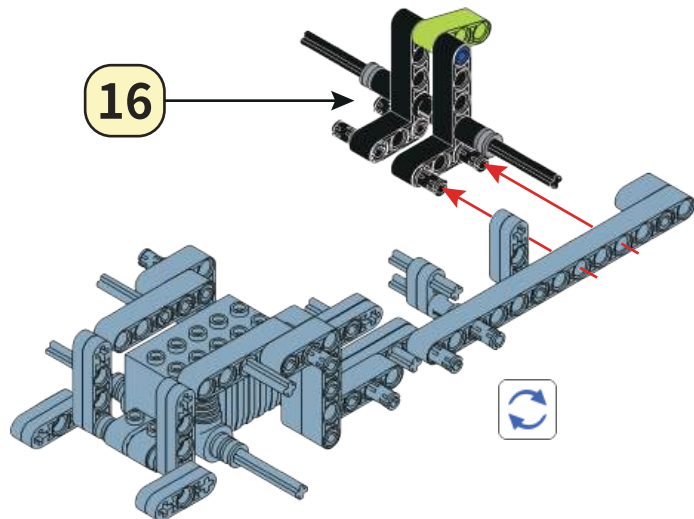

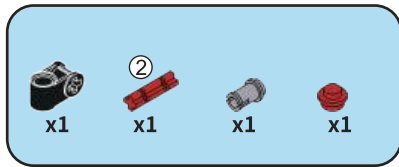

17

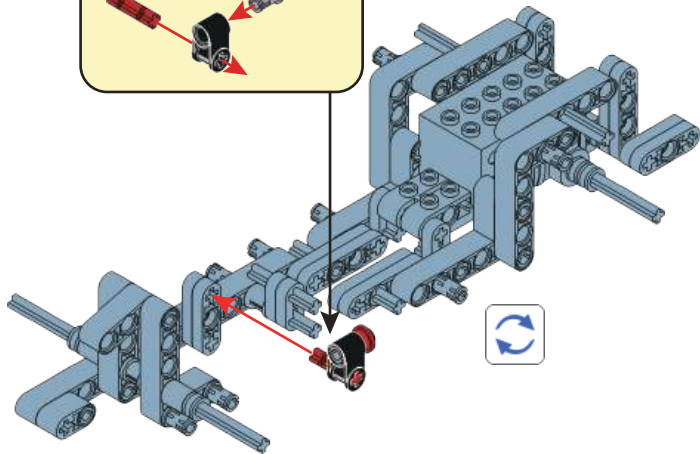
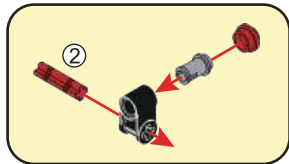

18

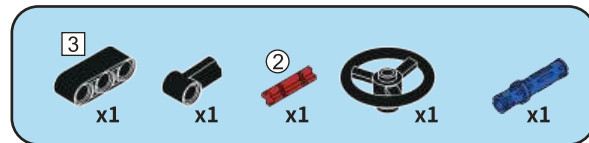
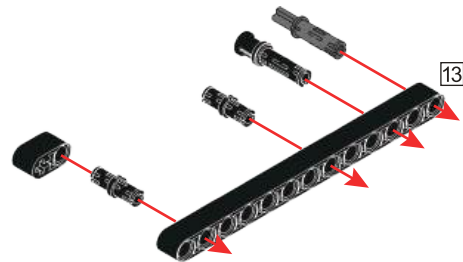

19

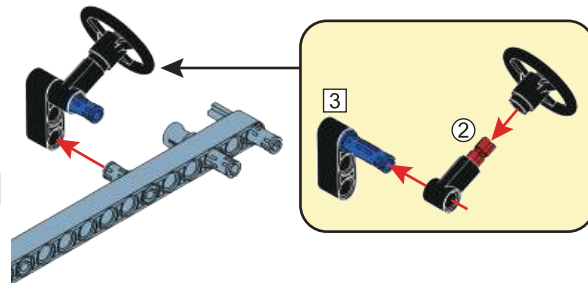

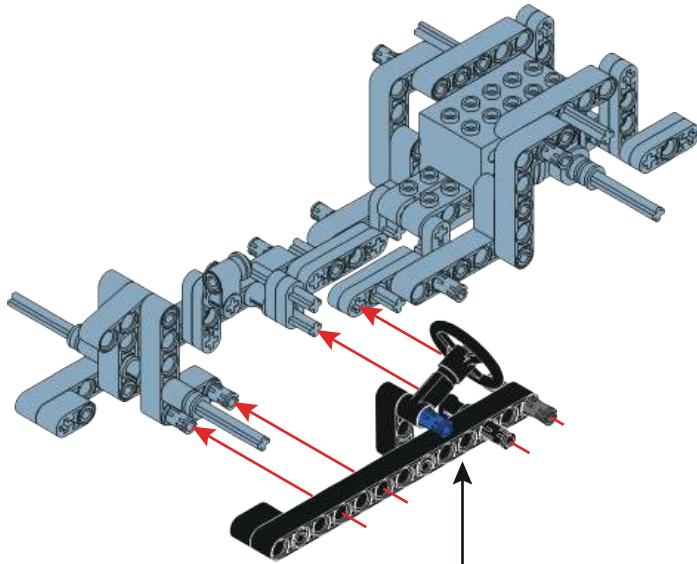

19

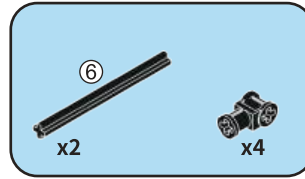

20

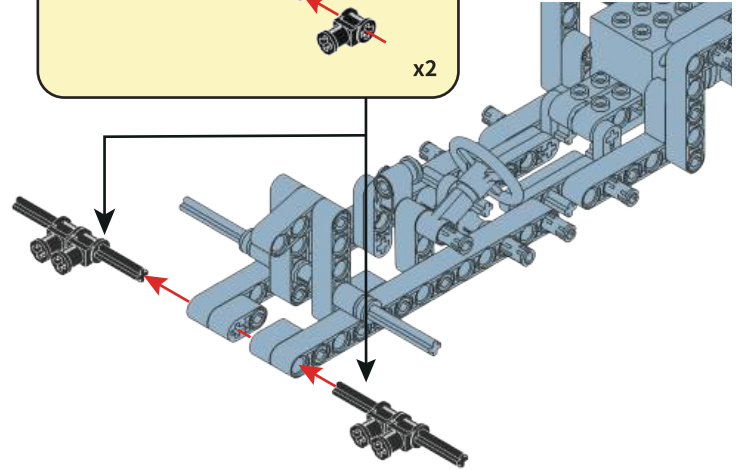
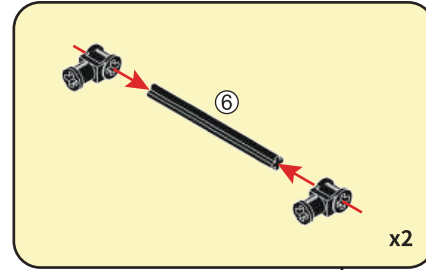

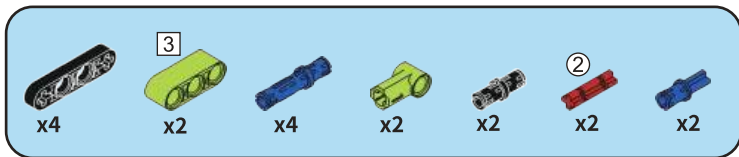

21

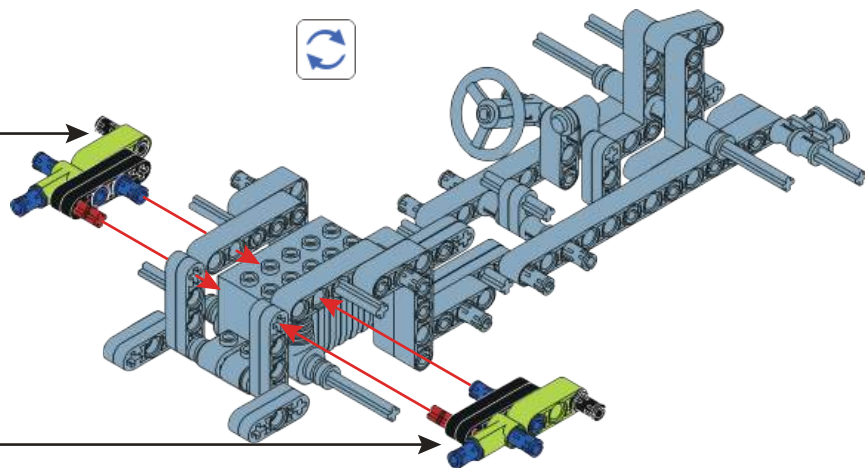
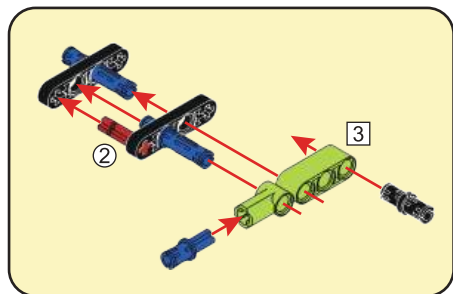
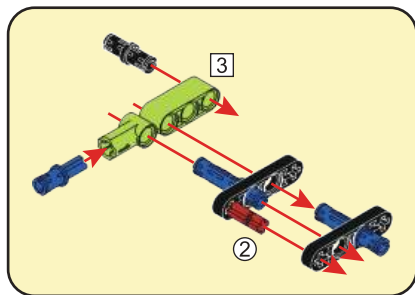

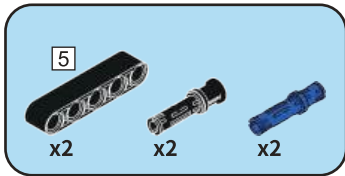

22

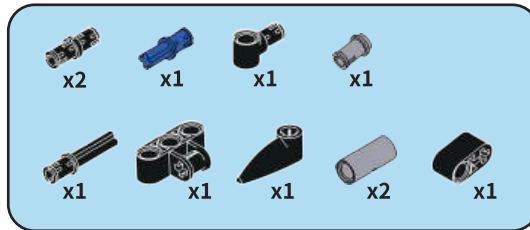
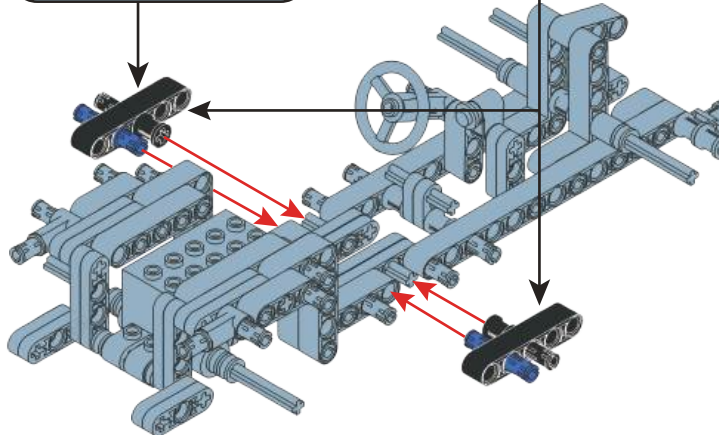
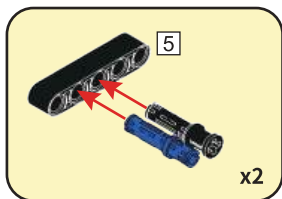
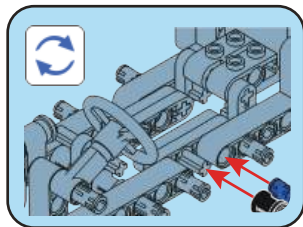

23

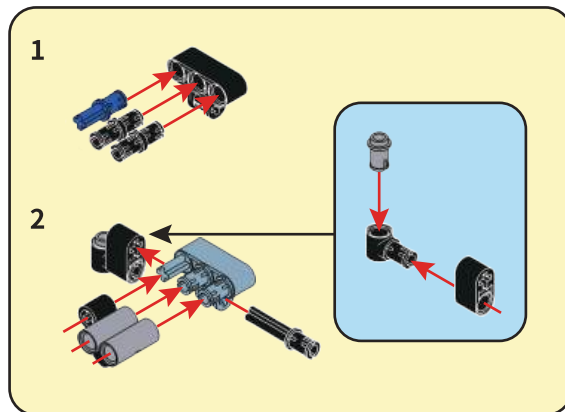

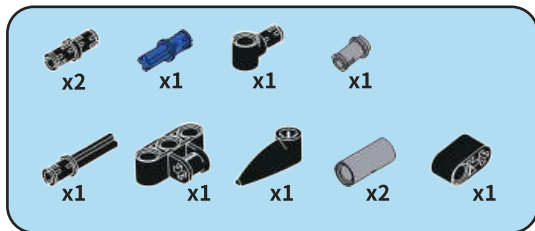

24

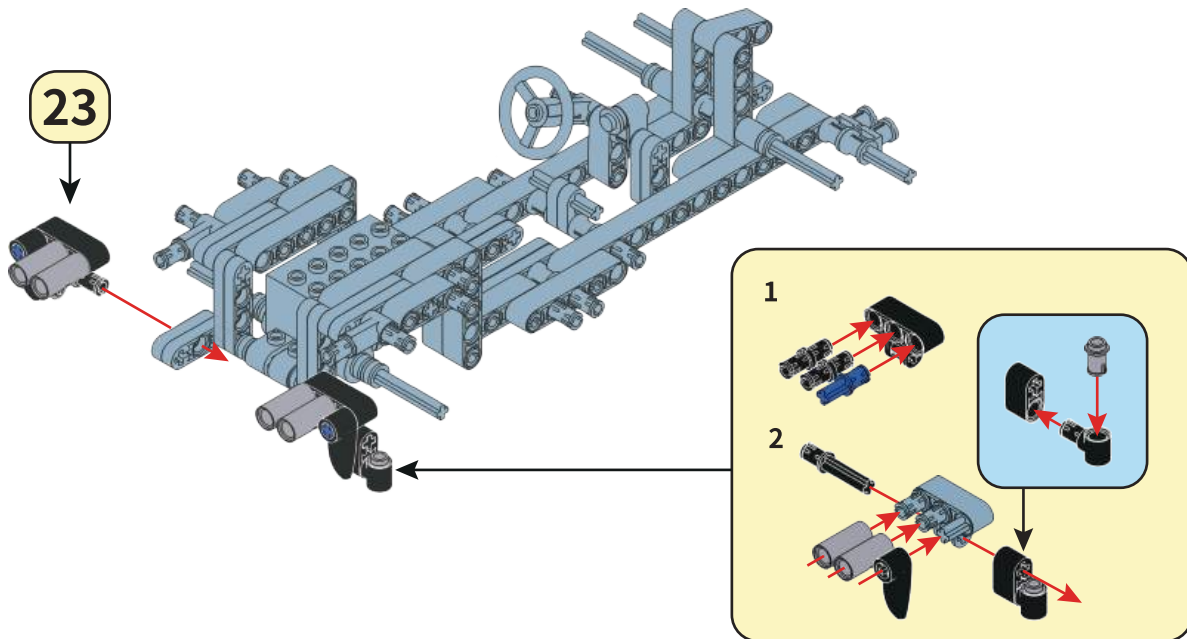

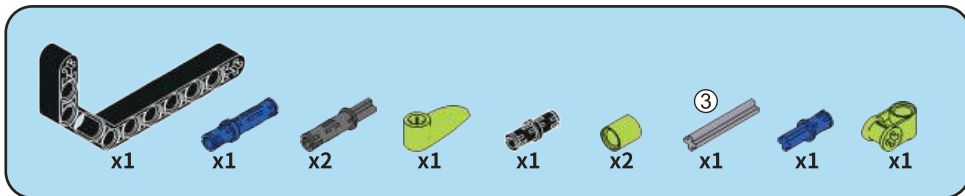

25

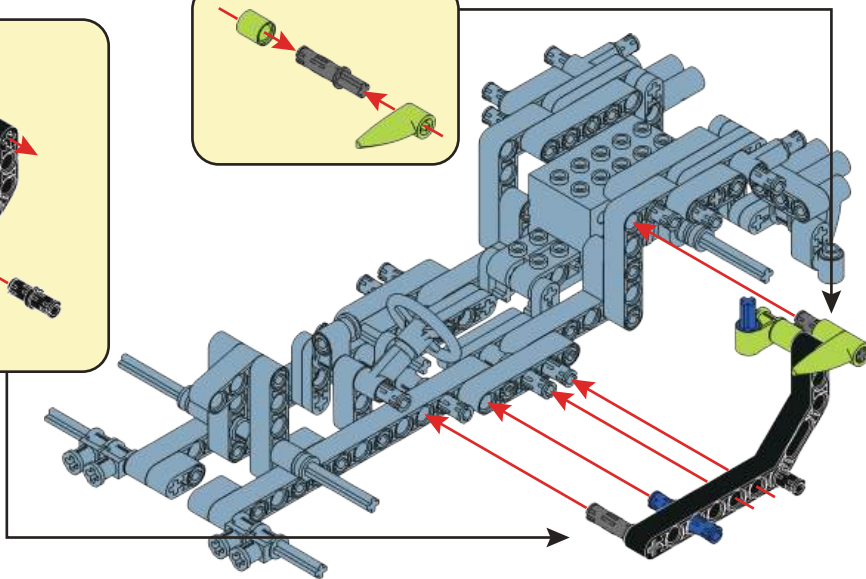
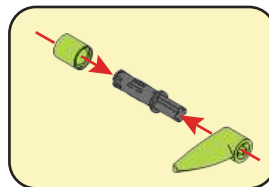
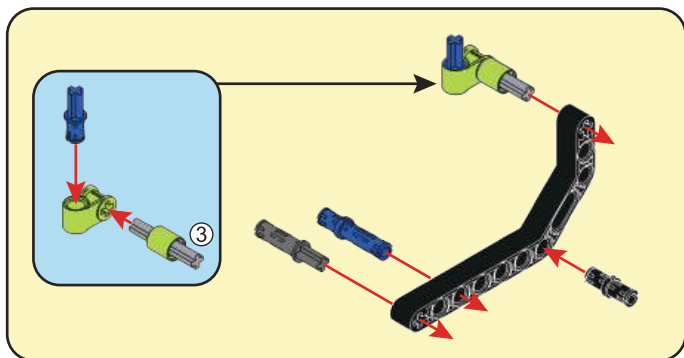

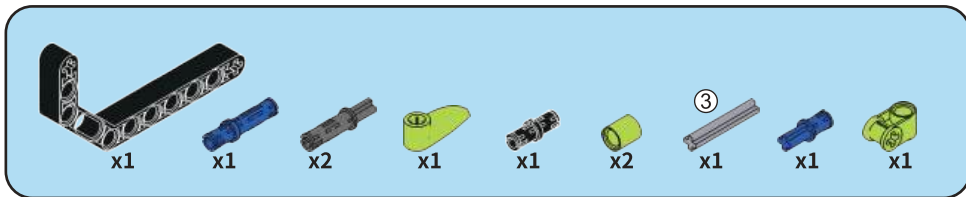

26

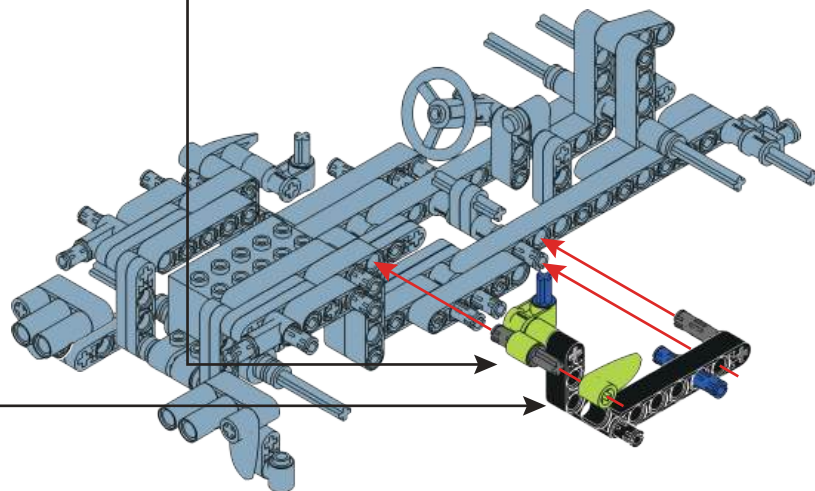
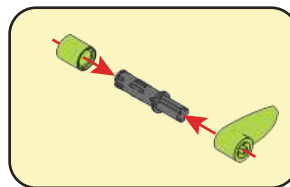
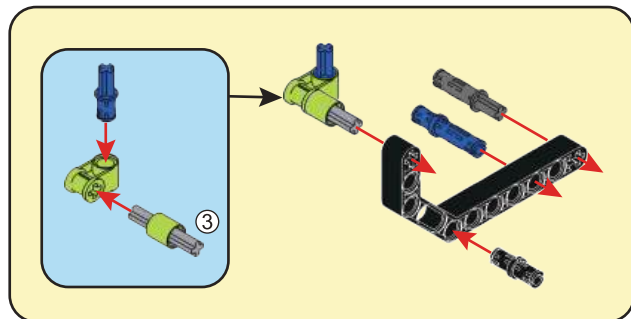

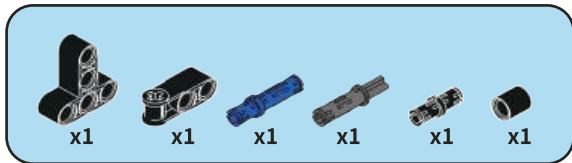

27

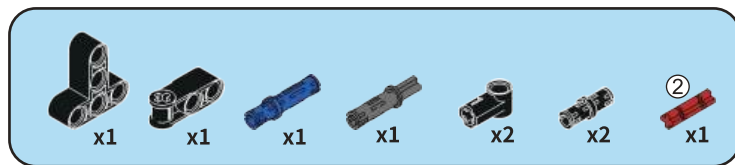
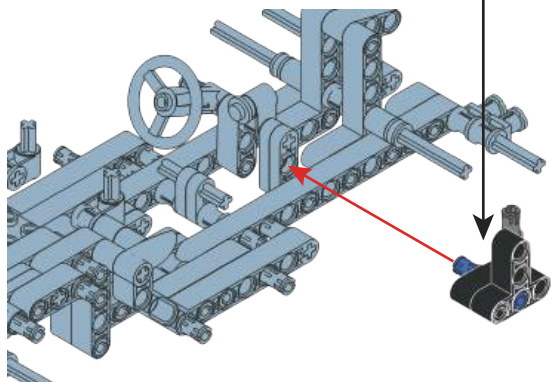
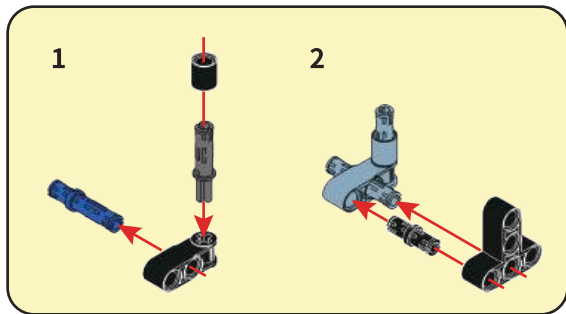

28

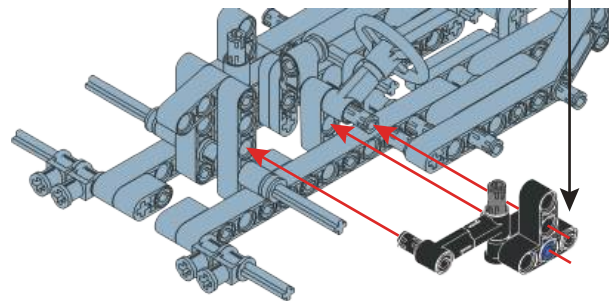
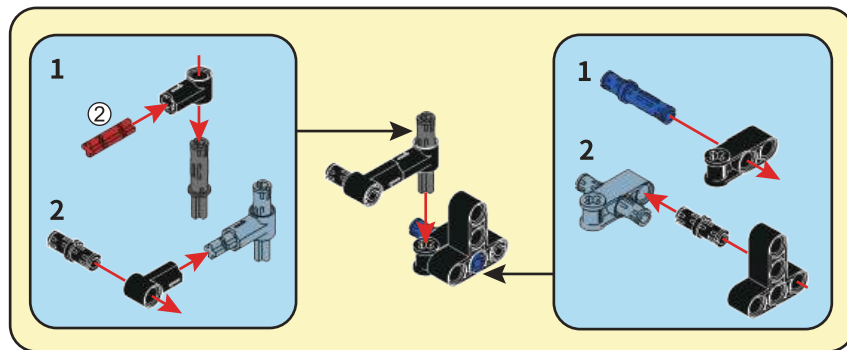

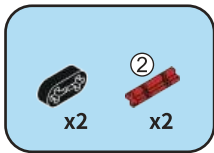

29

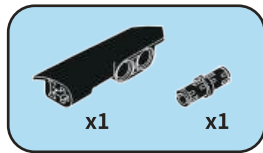
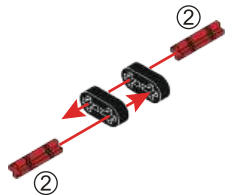

30

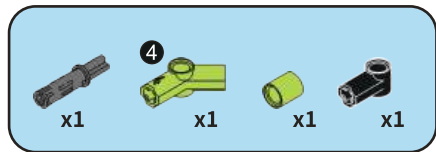
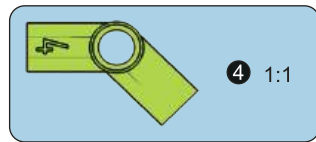
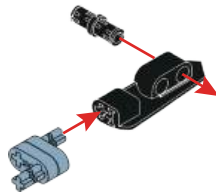

31

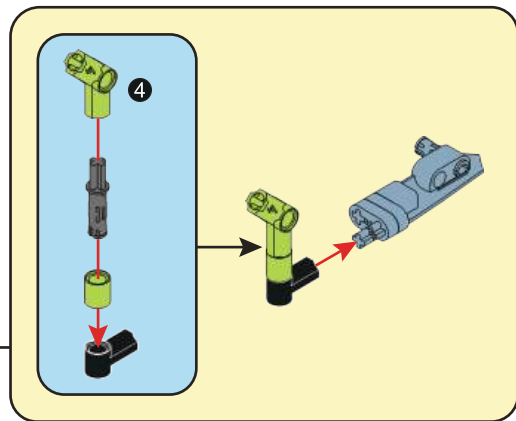
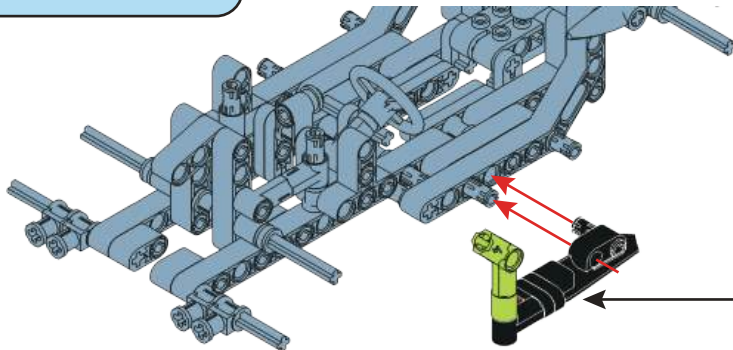

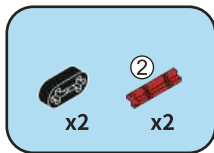

32

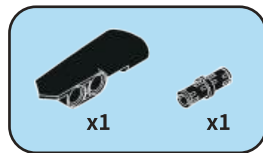
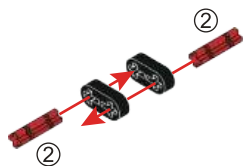

33

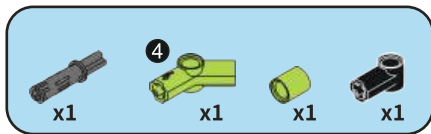
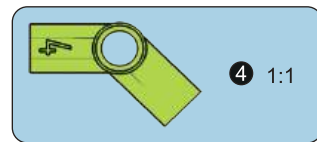
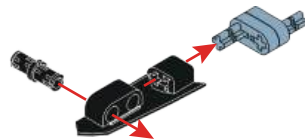

34

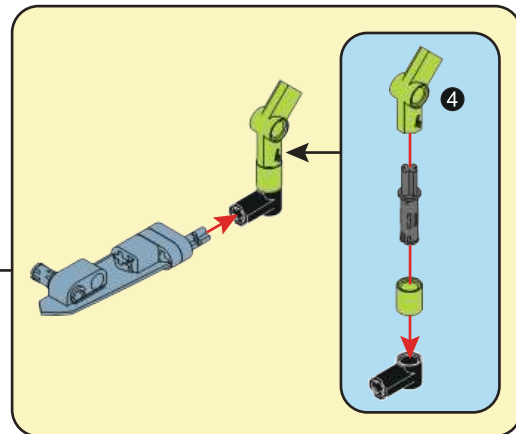
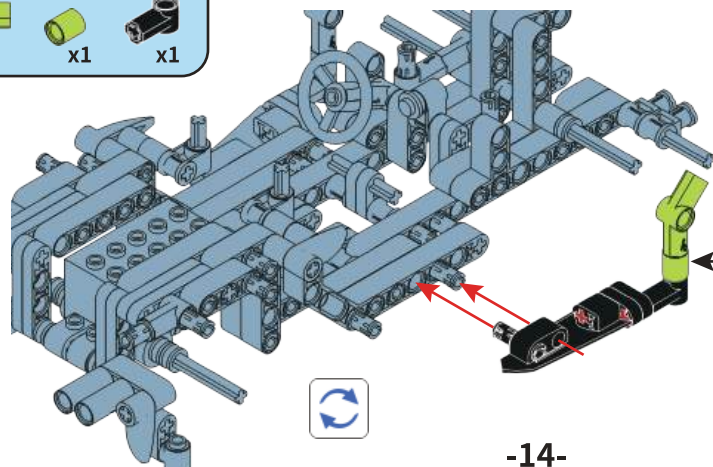

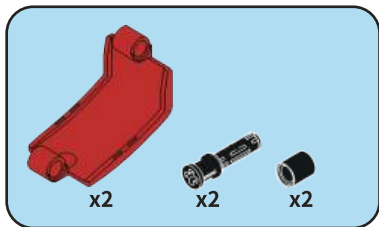

35

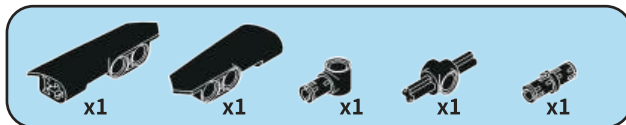
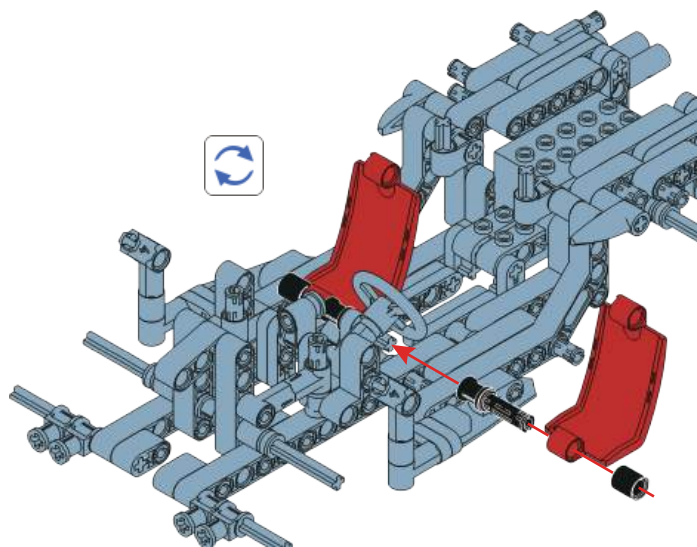

36

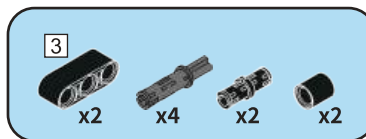
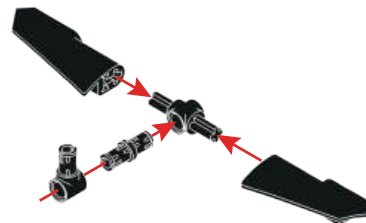

37

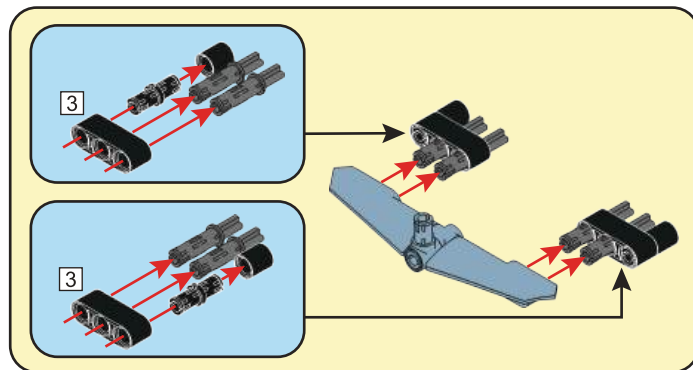

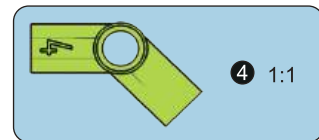
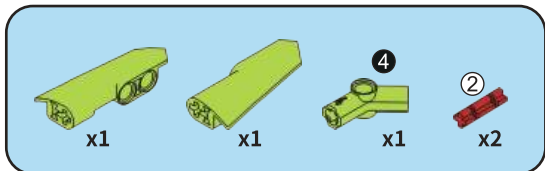

38

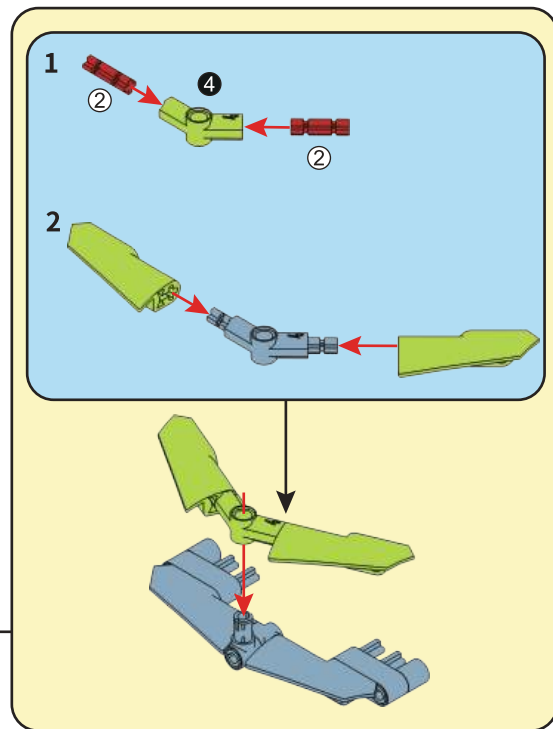
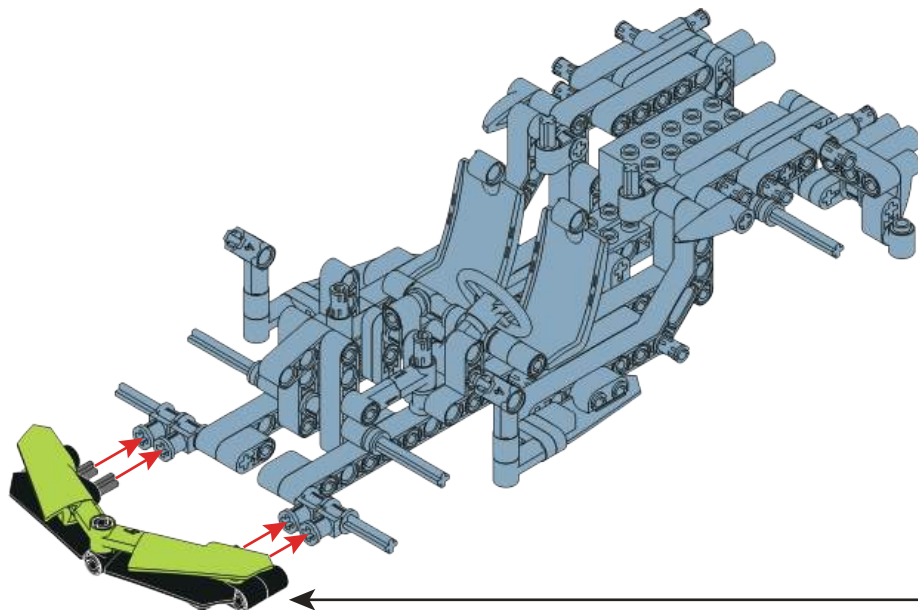

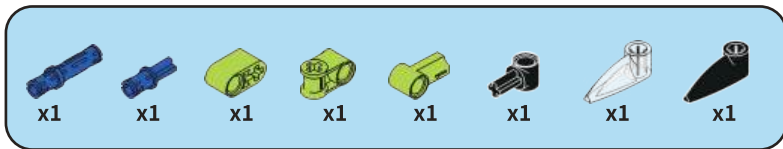

39

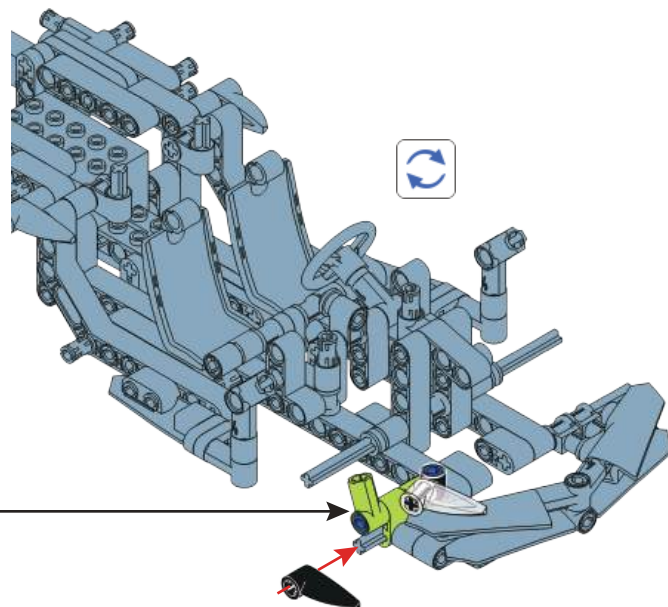
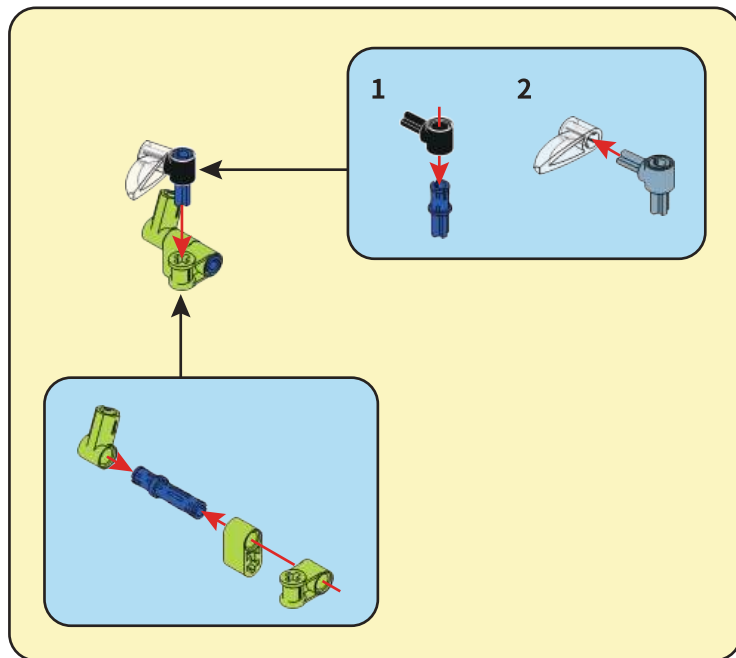

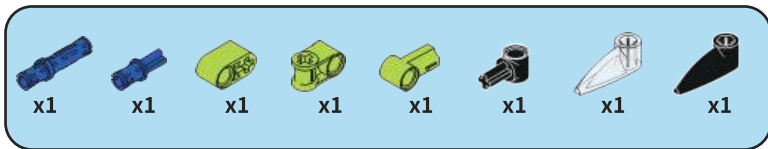

40

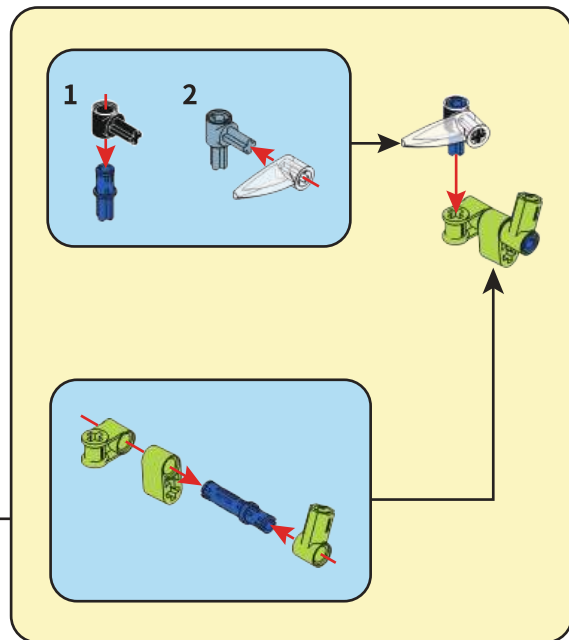
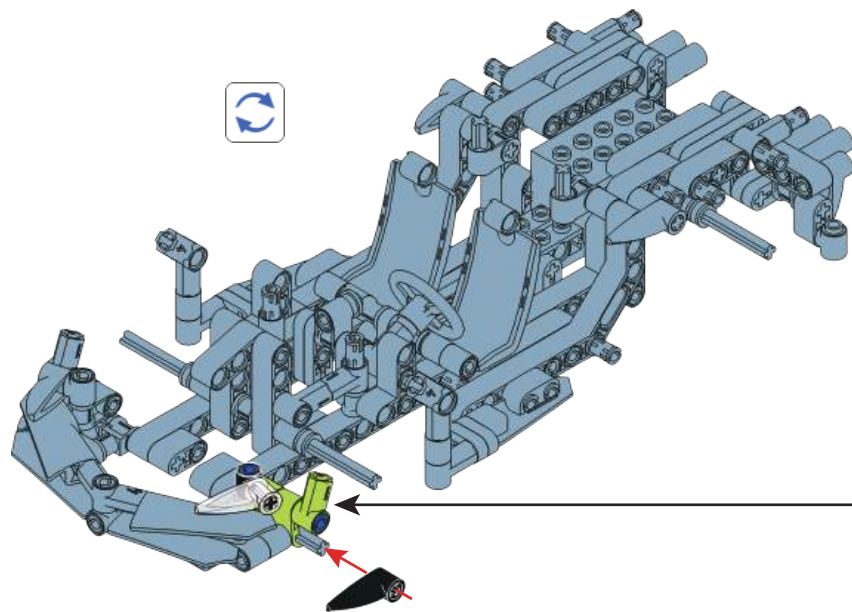

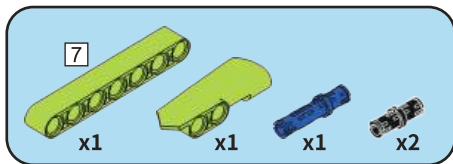

41

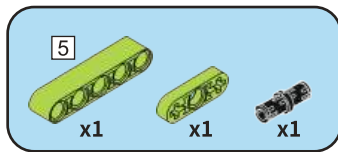
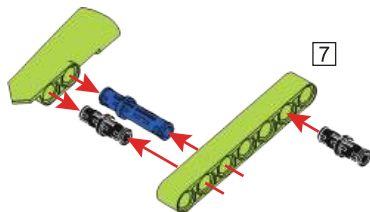

42

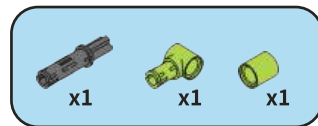
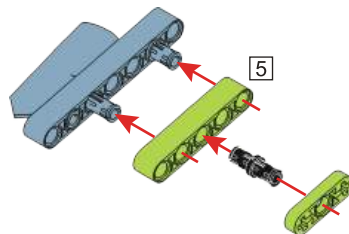

43

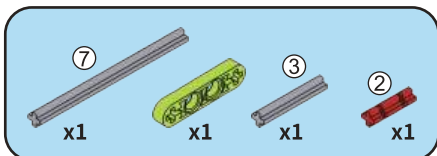
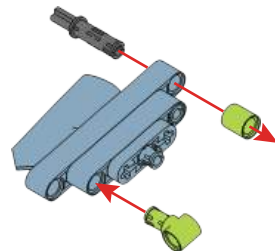

44

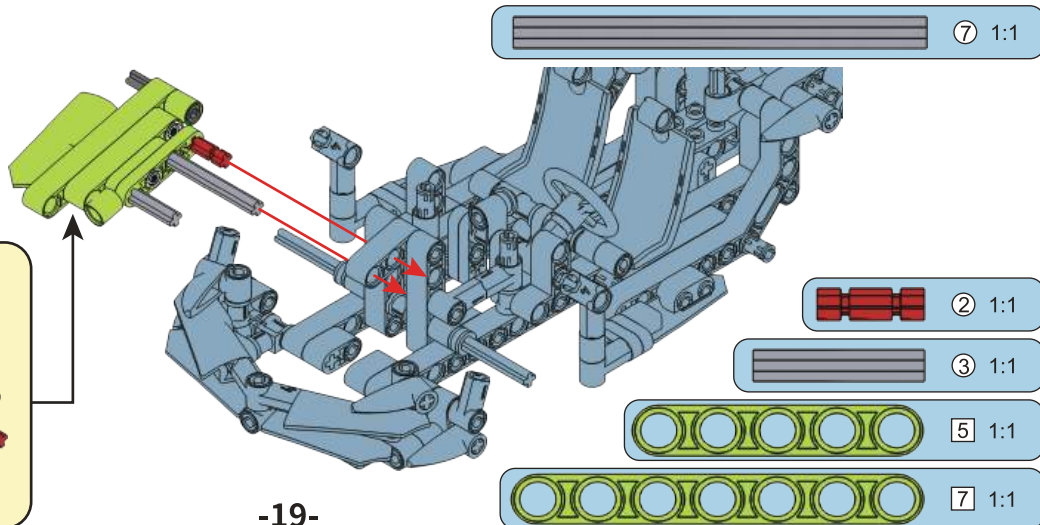
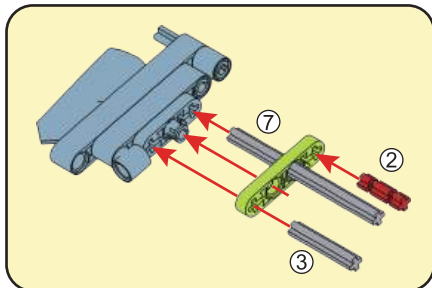

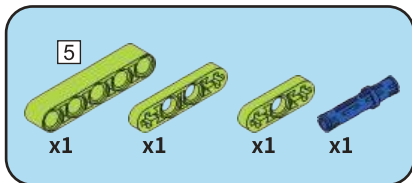

45

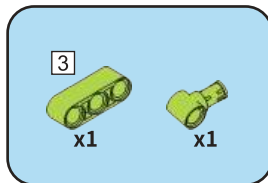
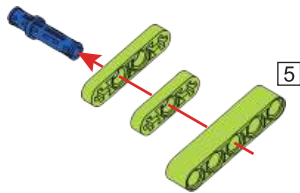

46

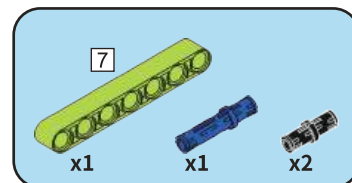
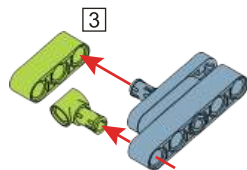

47

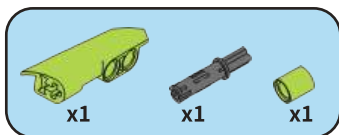
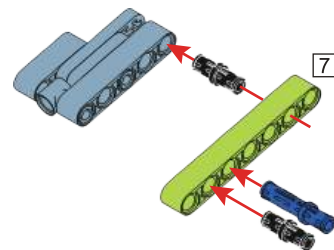

48

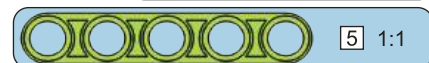
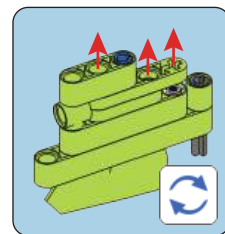
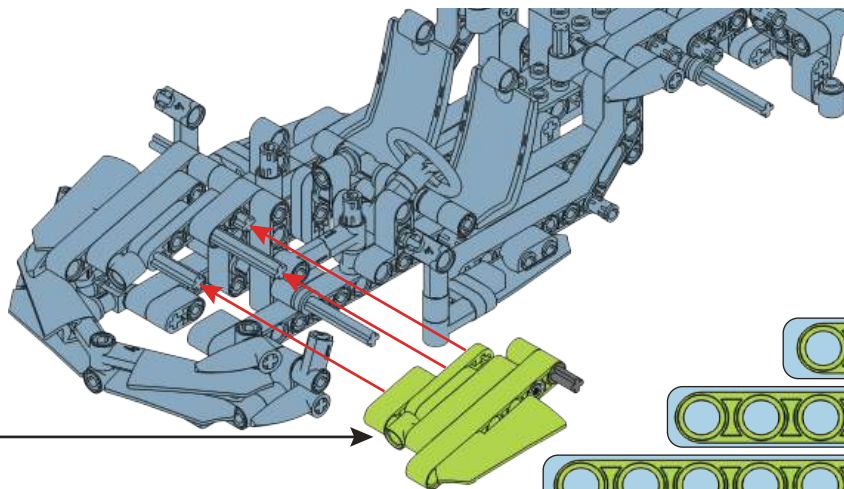
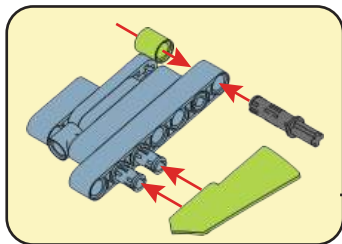

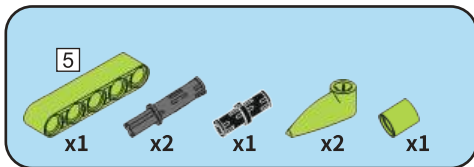

49

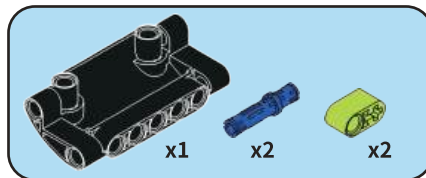
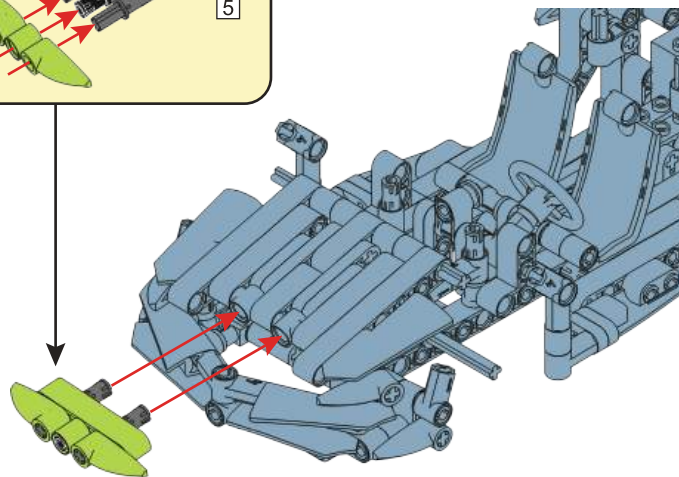
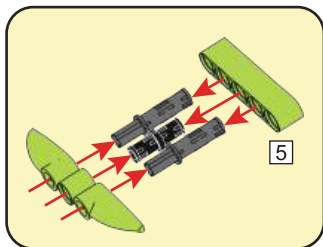

50

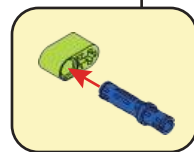
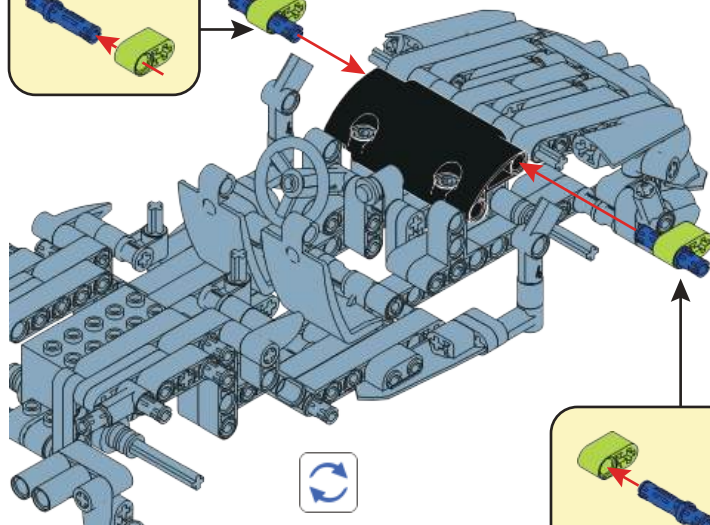
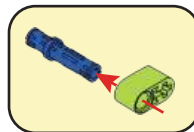

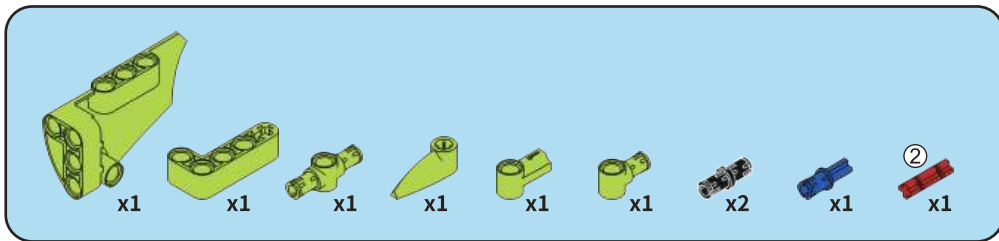

51

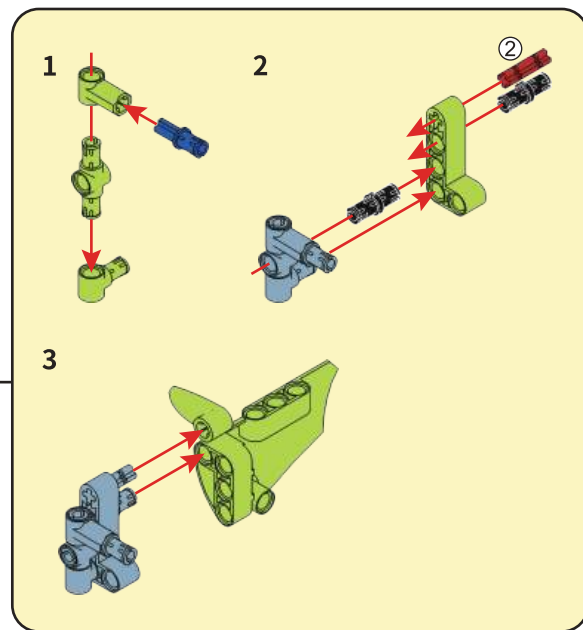
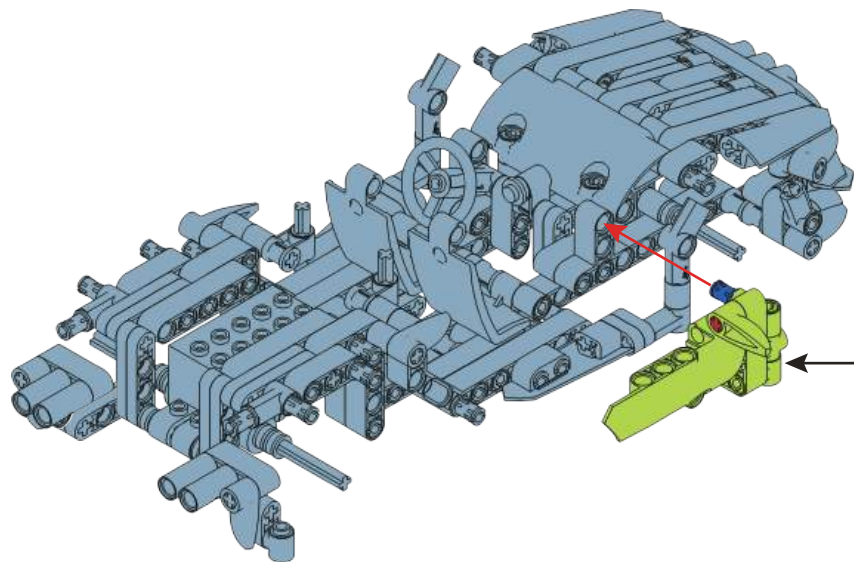

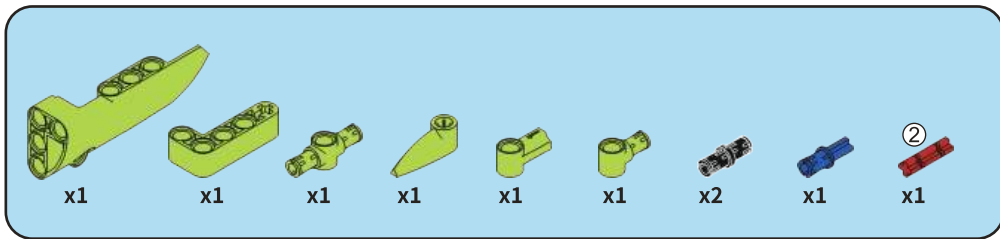

52

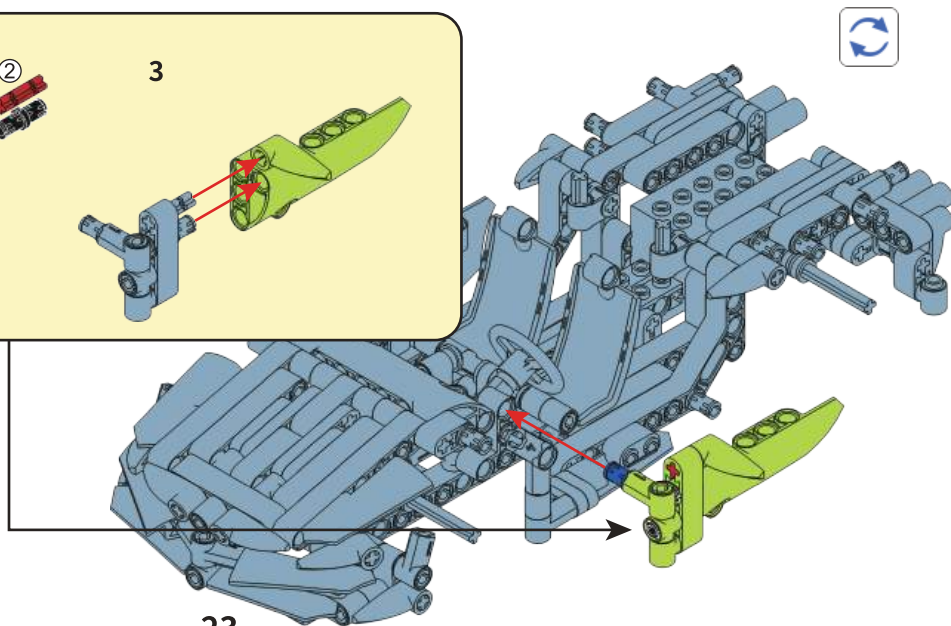
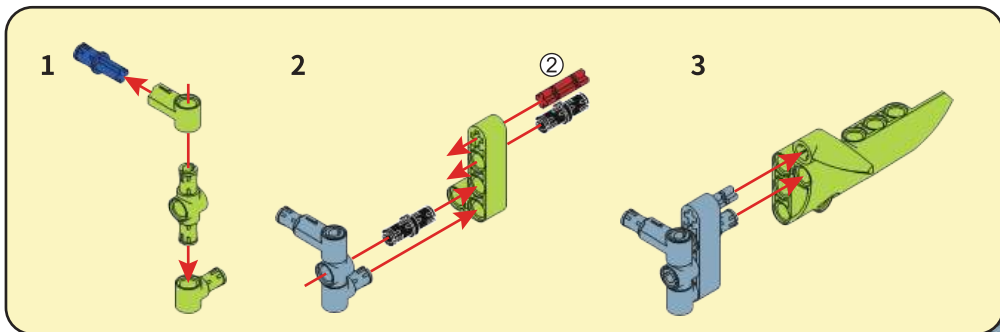

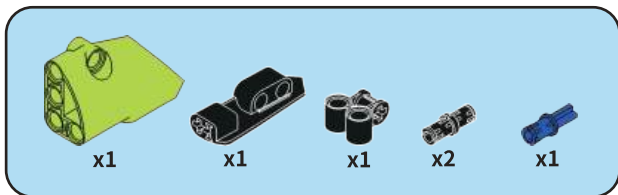

53

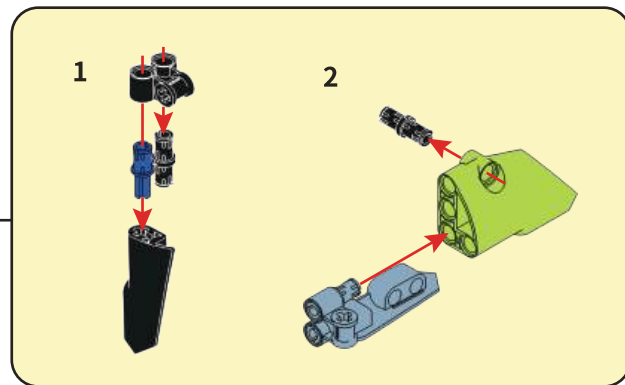
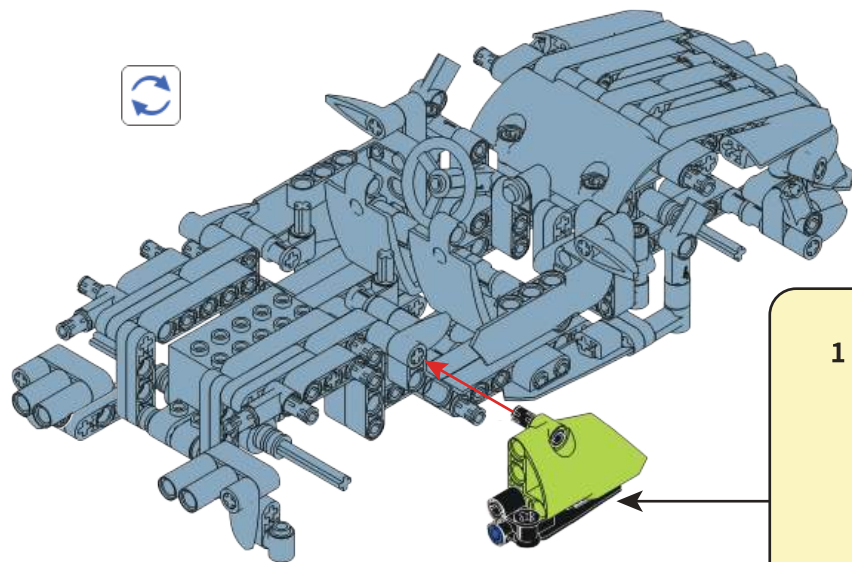
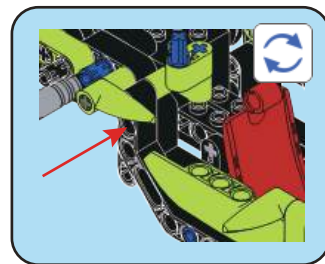

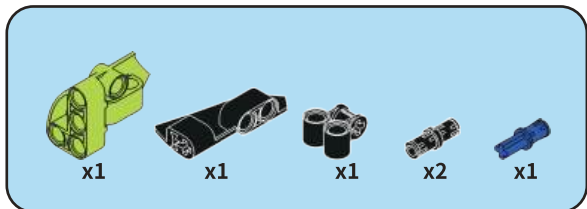

54

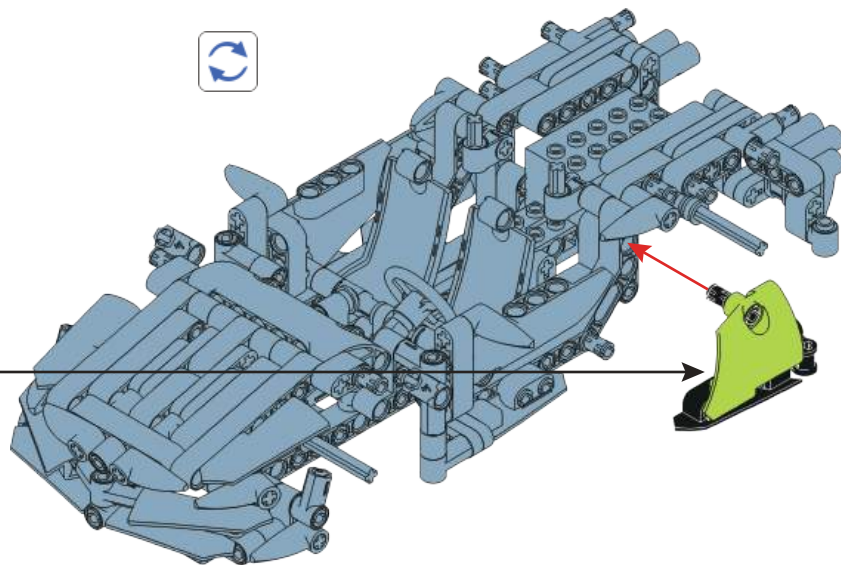
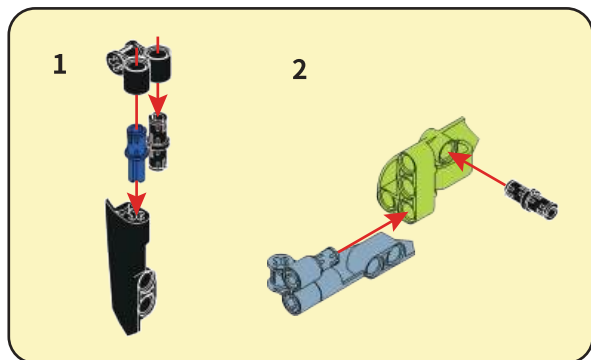

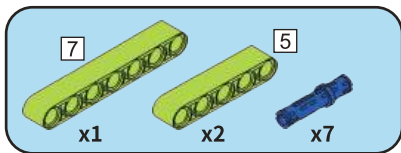

55

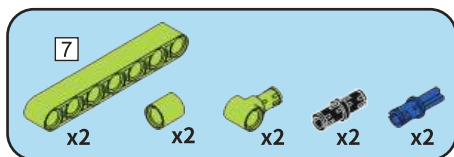
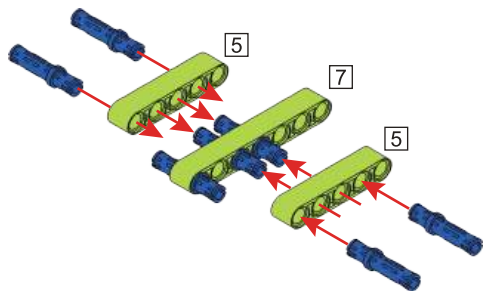

56

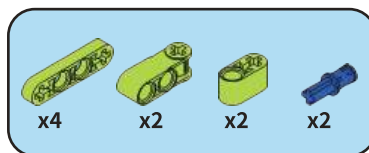
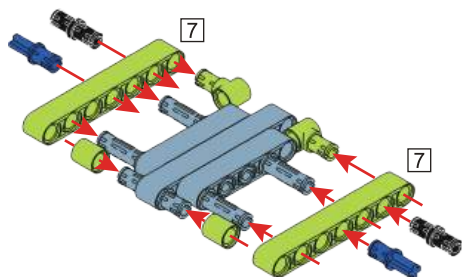

57

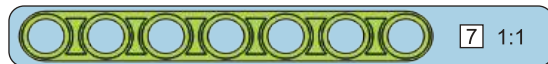
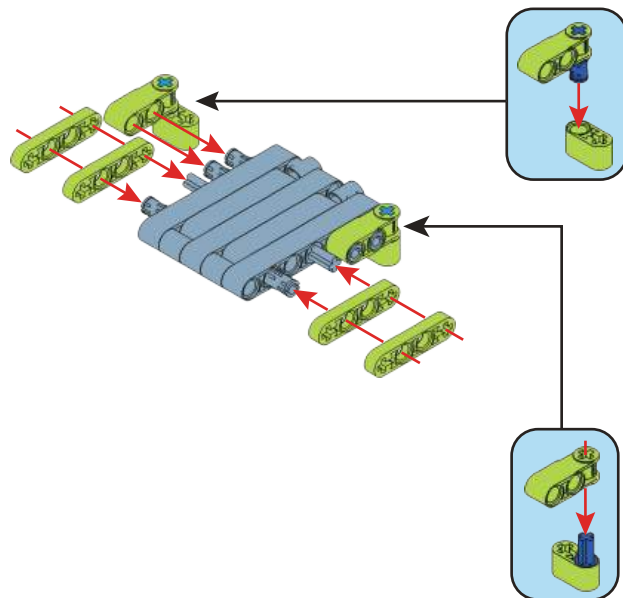

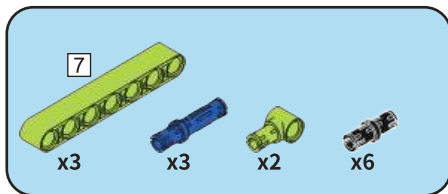

58

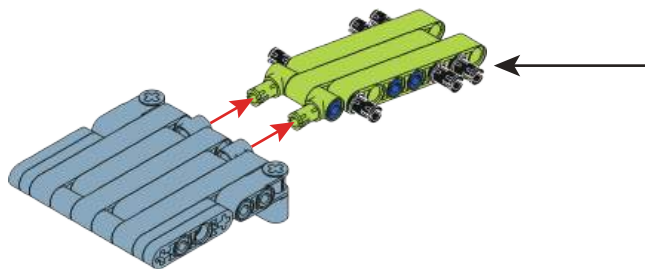
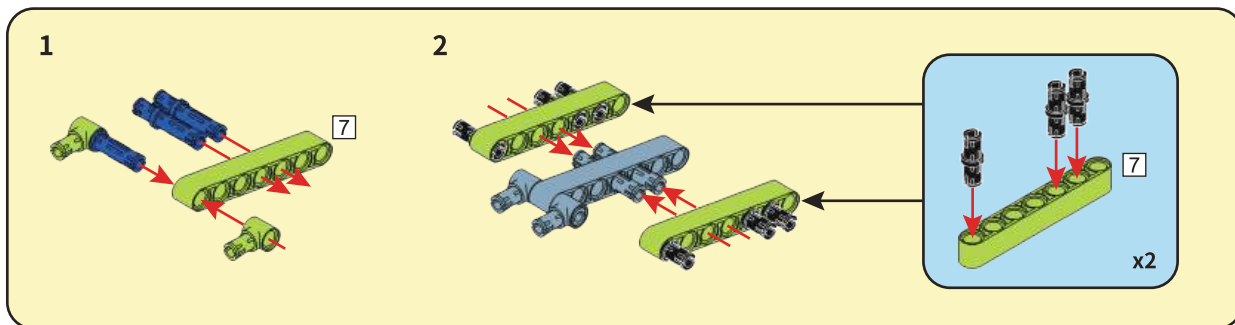

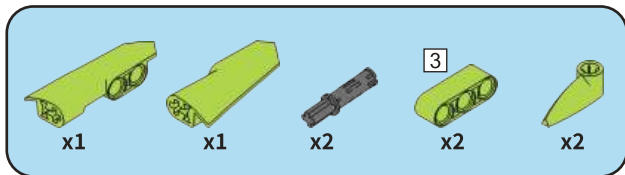

59

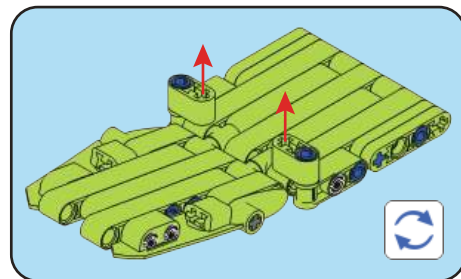
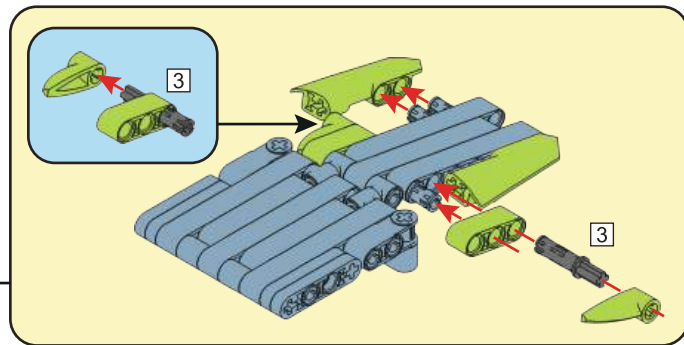
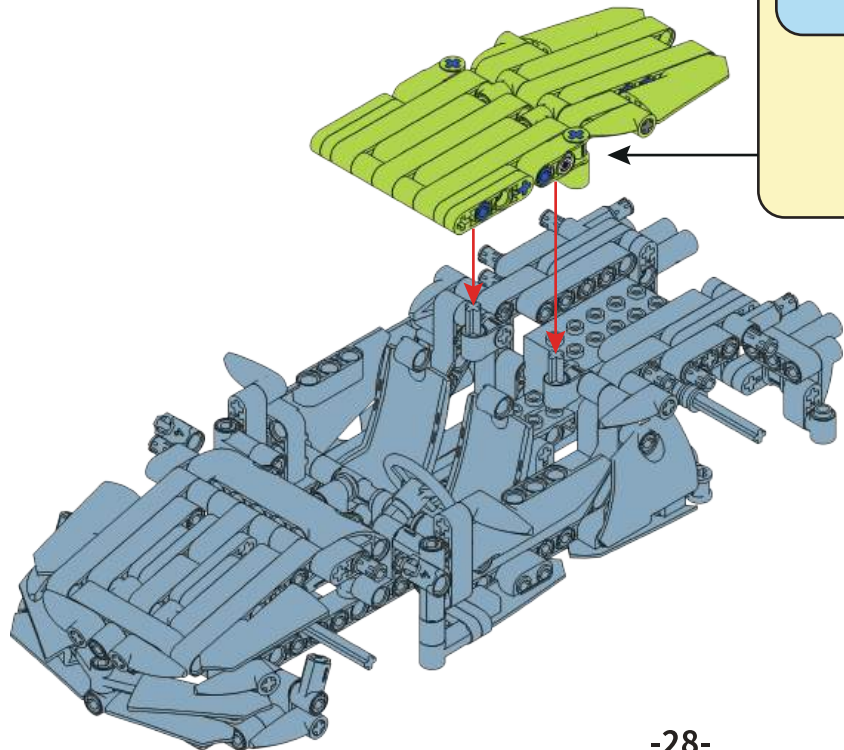

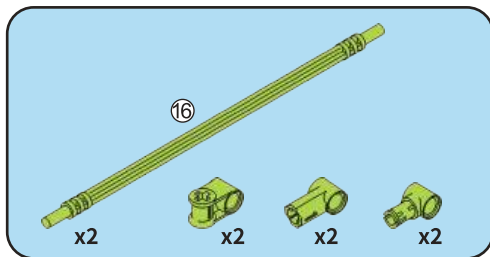

60

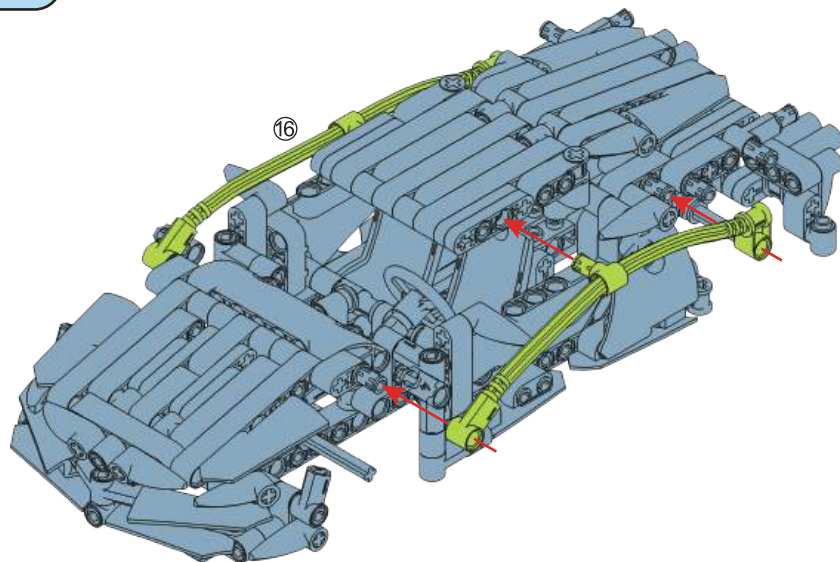

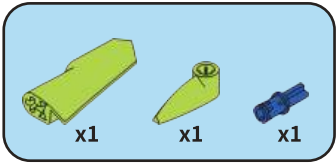

61

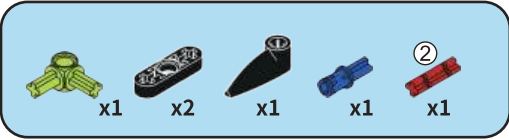
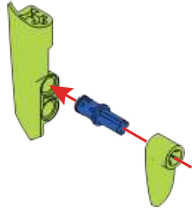

62

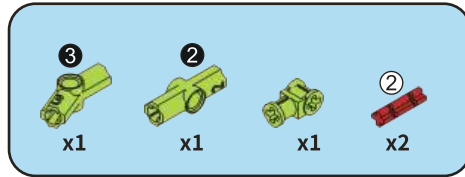
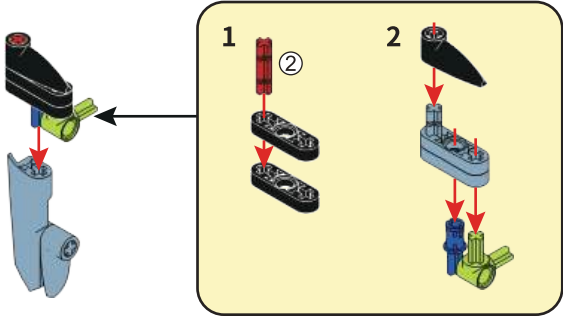

63

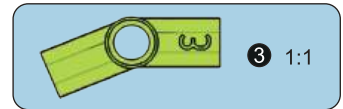
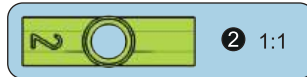
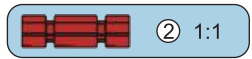
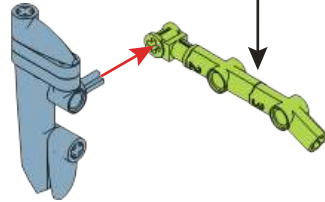
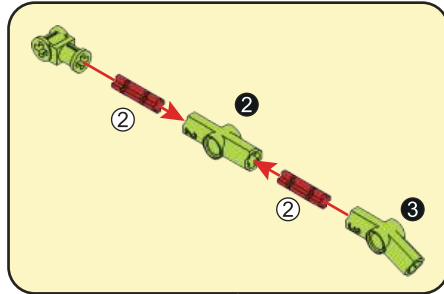

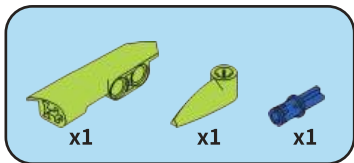

64

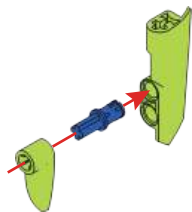

65

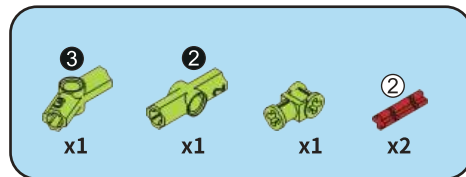
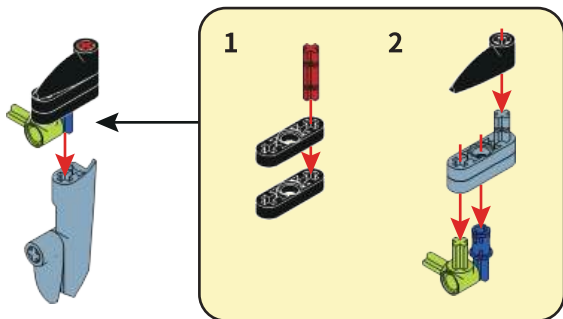

66

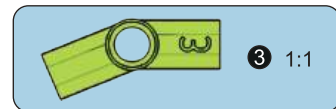
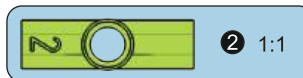
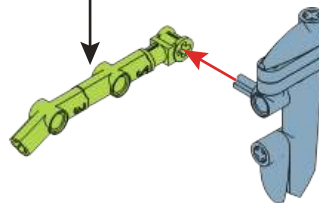
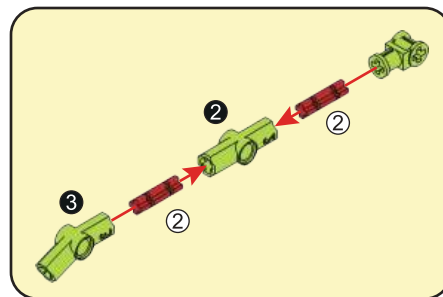

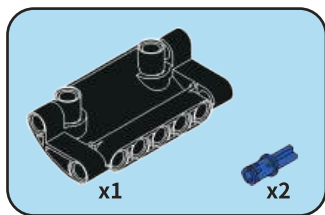
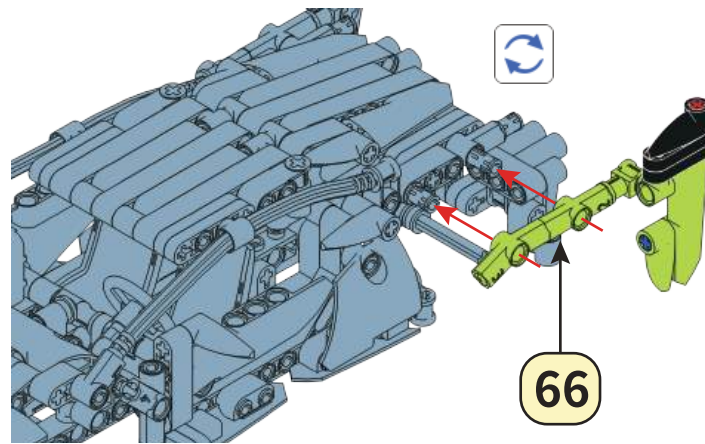
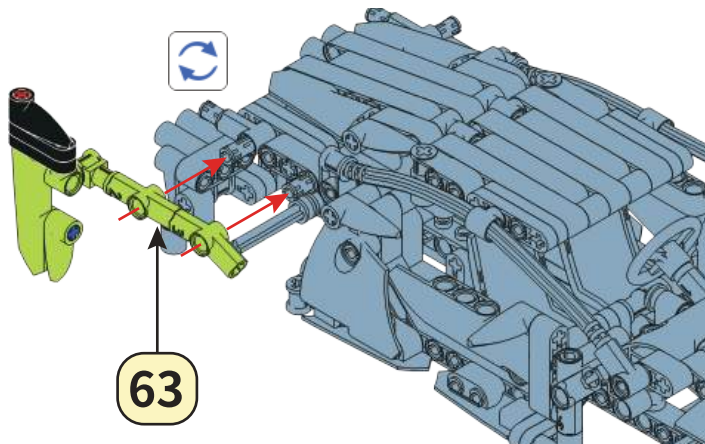

67

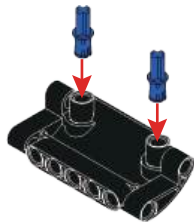

68

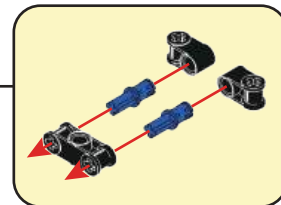
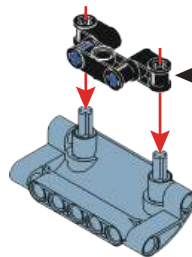

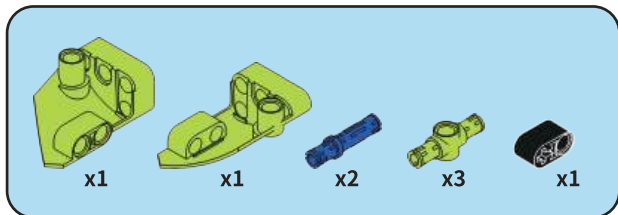

69

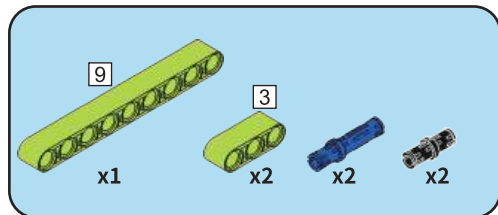
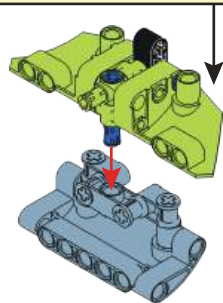
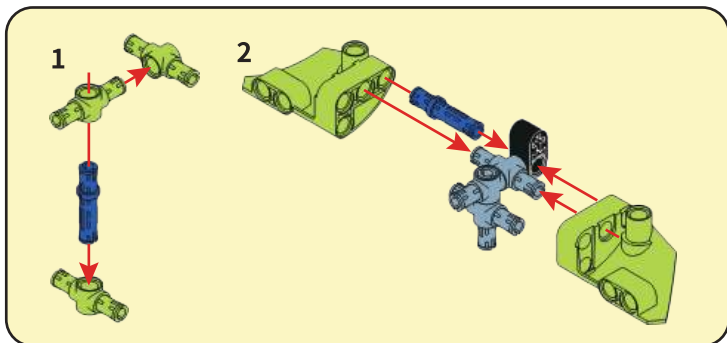

70

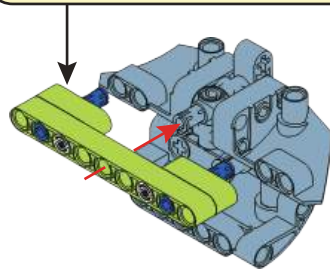
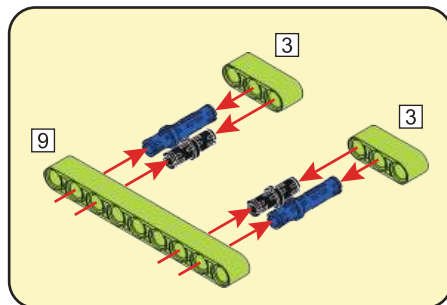

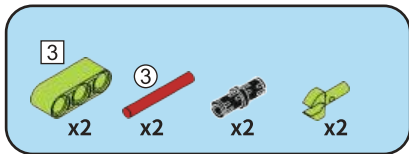

71

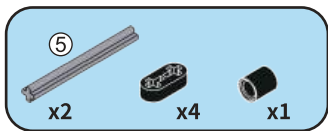
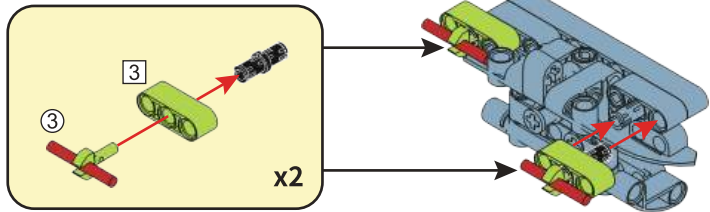

72

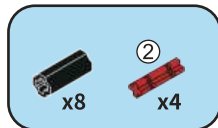
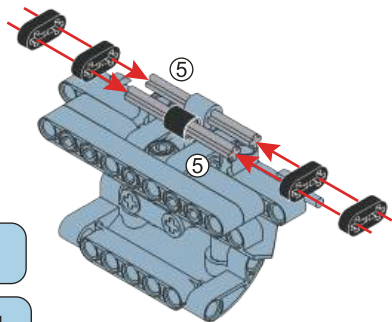

73

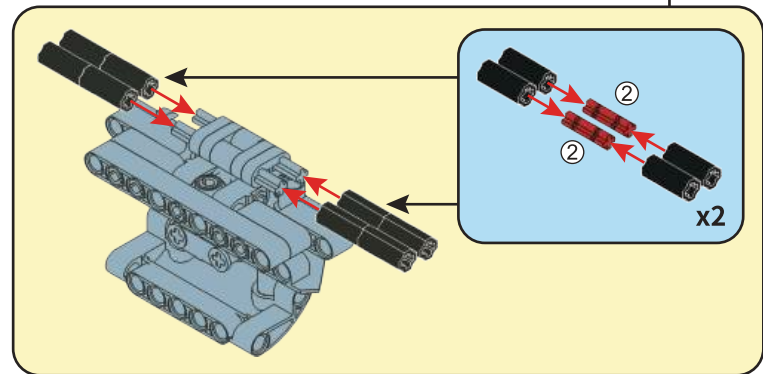
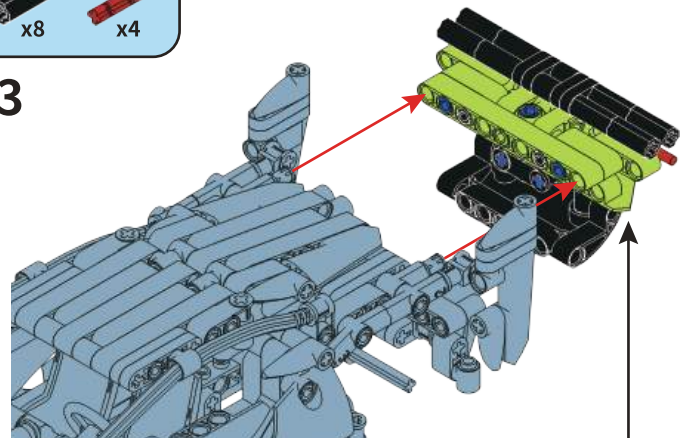

-34-





73

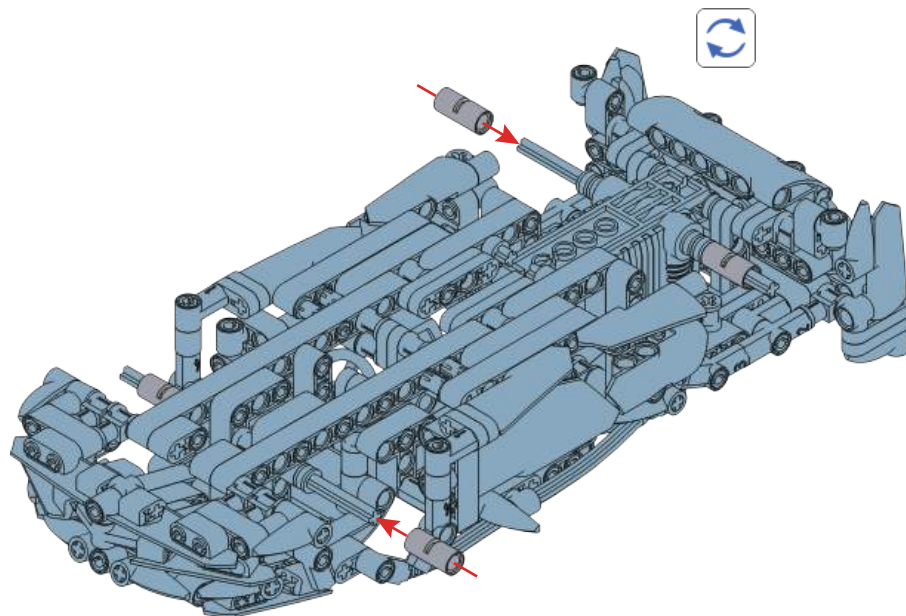

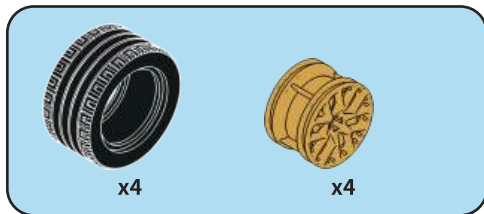

74

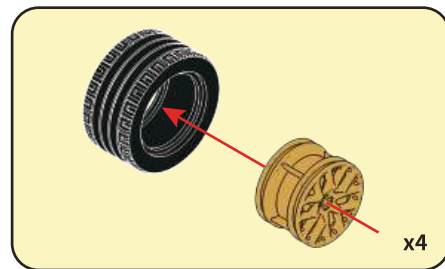
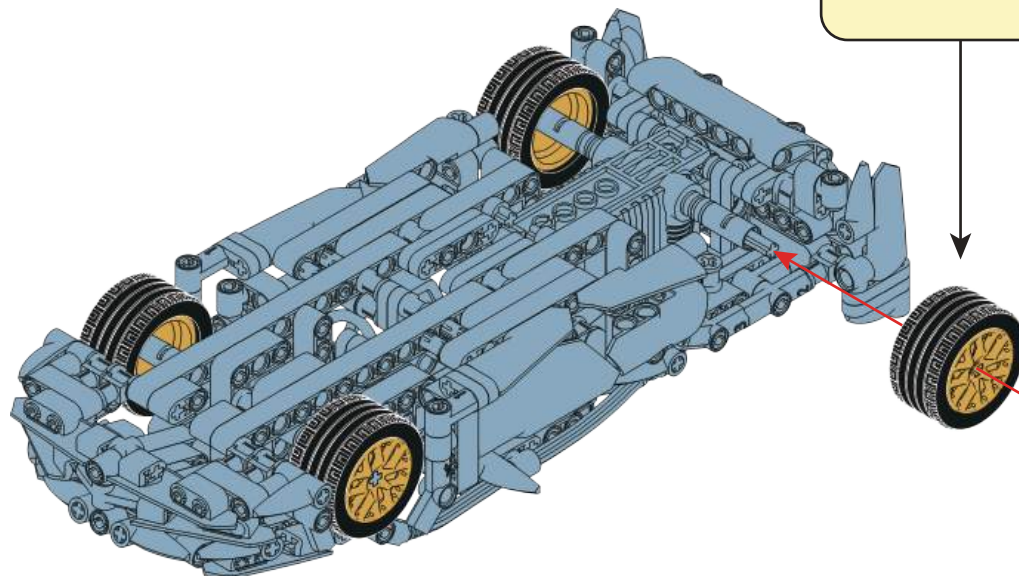

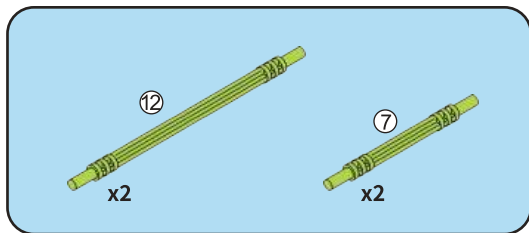

75

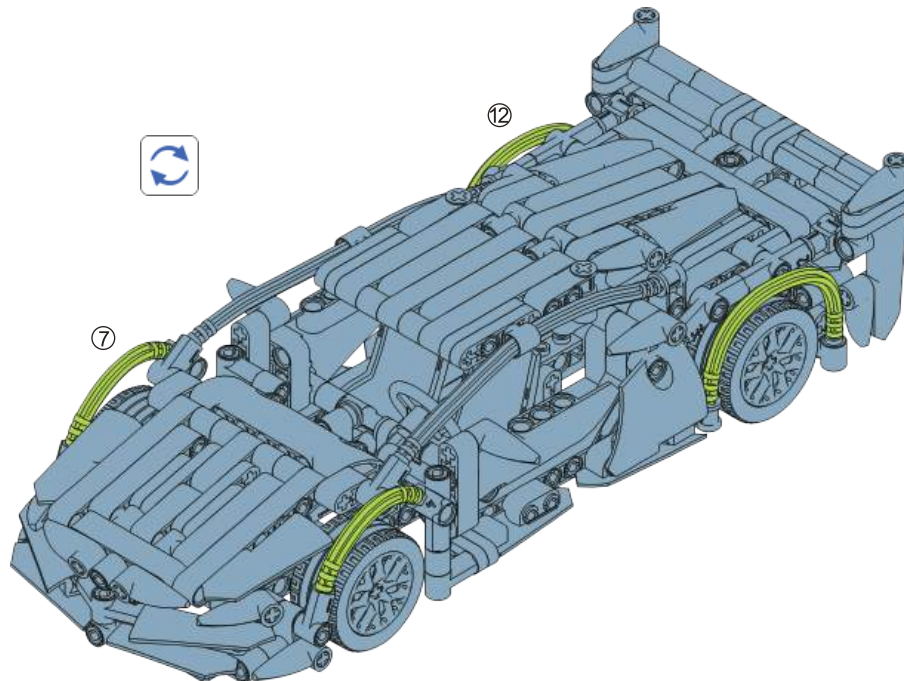

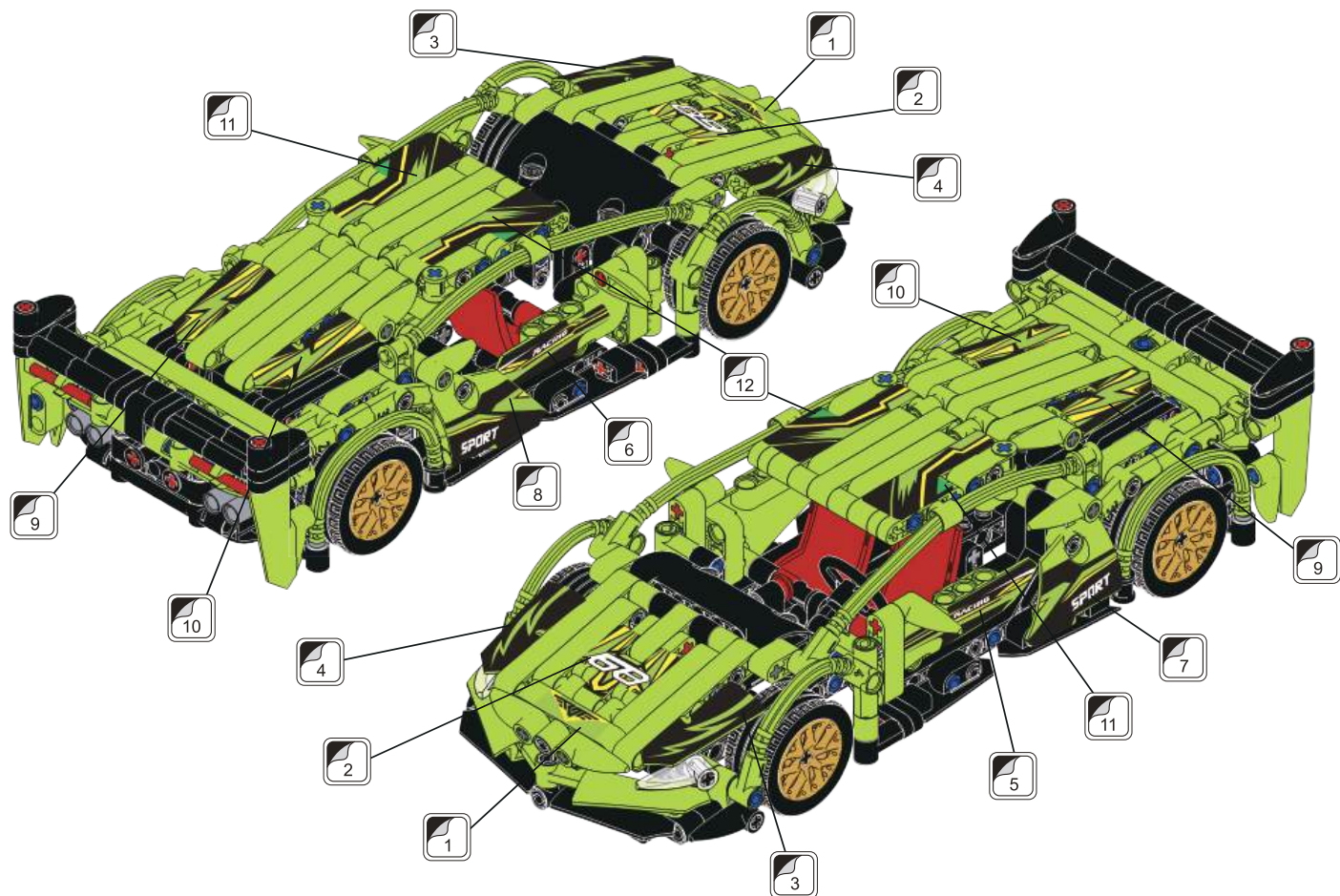



Realistic model



Quick and powerful rebound